

# ENGINEERING MANUAL

Fast & Simple to Use  
Online Configurator

Patent Pending Pinch  
Drive Design

Clean Room Certified  
Class 100

Industry-Best  
Product Transfers



## 1100 SERIES CONVEYORS

The Industry's Smallest Conveyor  
Designed to Fit in the Tightest Spaces!

**DORNER**<sup>®</sup> 

## Miniature Frame Design

- 19 mm (.75 in) frame height
- 16 mm (.625 in) or 8 mm (.3125 in) diameter idler pulleys
- Optimal size for handling and transferring of small parts
- T-Slot for fast mounting of accessories
- Flush edge design to fit into tight spaces
- Cam belt tracking conveyor extends only 19mm (3/4 in) beyond frame



## Pinch Drive Design (Patent Pending)

- Low belt tension virtually eliminates belt stretch providing maintenance free operation
- Belt is tracked continuously with unique frame design, cams, and pinch drive for consistent performance
- Drive is reversible, providing maximum flexibility in applications
- Two half design with one fastener per side allows cover to pivot for fast belt change
- T-Slot for flexible mounting
- Spring tensions belt around drive pulley for 180° of wrap
- 32 mm (1.25 in) lagged urethane drive spindle

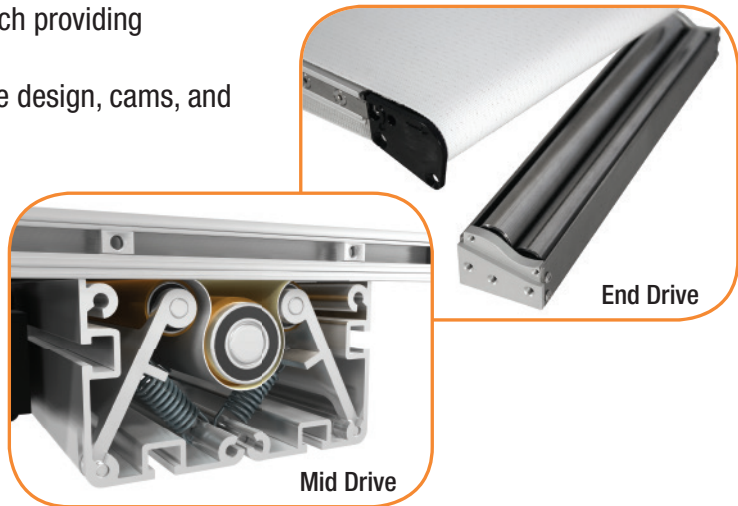

## Backlit Capability

- Backlit conveyor with an LED light is ideal for inspection and quality control
- Provides a contrast between the product and conveyor belt for both visual inspection and vision system interface
- Parts can be stopped directly over the lighted section or continue through uninterrupted
- Unique design allows access to LED panel without removal of the belt for ease of use and light color changes

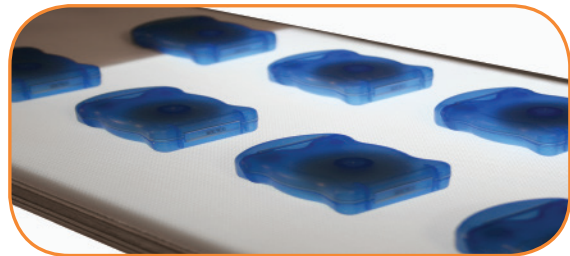

## The Benefits of a Dorner 1100 Series Conveyor

### Industry Ready

- Clean Room Class 100 Certified for medical and pharmaceutical applications
- T-Slot for ease and flexibility in mounting automation components or accessories
- FDA Approved Belting

### Time Saving

- Dorner's online configuration engineers simple or complex conveyors to meet your needs in minutes
- The industry leading tool delivers a complete 3D CAD Assembly model for instant validation of fit
- Dorner provides the industry's fastest deliveries

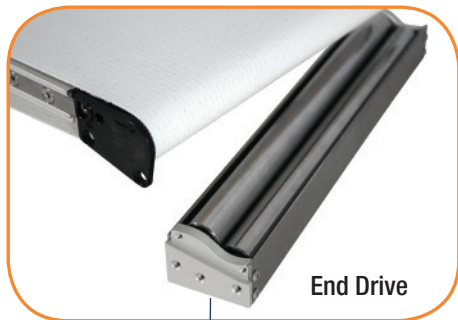
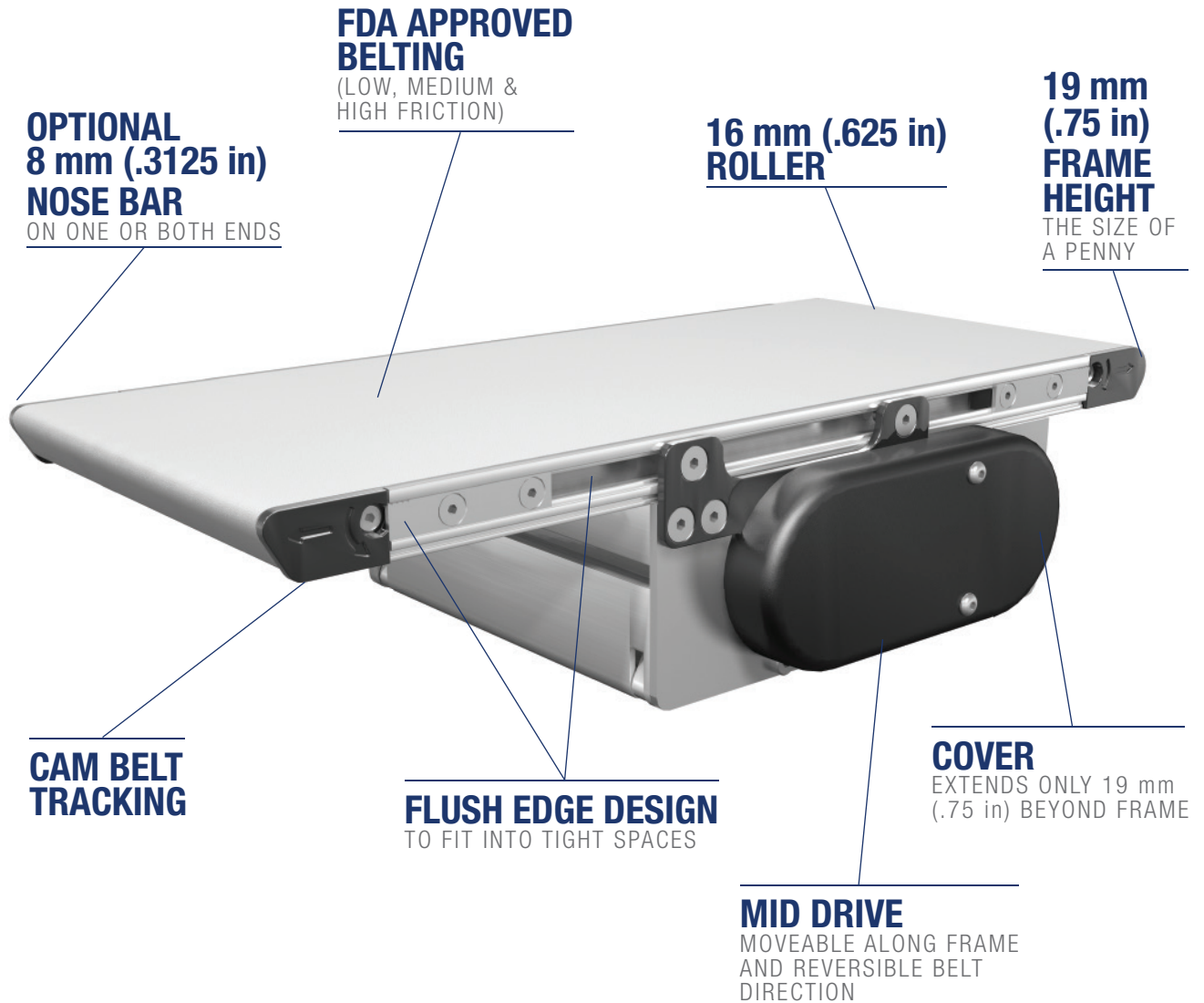

**PATENT PENDING  
TWO HALVE DESIGN**  
FOR QUICK BELT CHANGE

**32 mm (1.25 in) LAGGED  
URETHANE DRIVE SPINDLE**

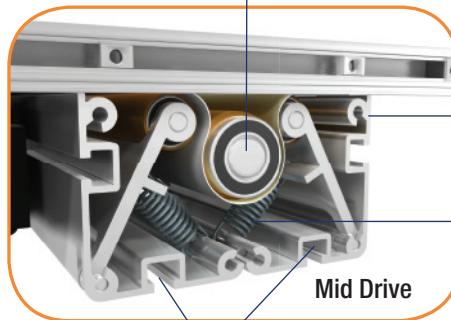

**T-SLOT**  
FOR FLEXIBLE MOUNTING  
TO SURFACES

**ONE FASTENER  
PER SIDE**

ALLOWS COVER TO  
PIVOT FOR FAST  
BELT CHANGE

**SPRINGS  
TENSION BELT**

AROUND DRIVE  
PULLEY FOR OVER  
180° OF WRAP



Bottom Mount



Side Mount

## Specifications

- Loads up to 6.8 kg (15 lbs)
- Belt Speeds up to 21 m/min (66 ft/min)
- Belt Widths: 44 mm (1.75 in), 95 mm (3.75 in), 152 mm (6 in), 203 mm (8 in), & 254 mm (10 in)
- Conveyor Lengths: 270 mm (10.63 in) to 1,829 mm (72 in) in 3 mm (0.125 in) Increments
- 25 mm (1 in) Diameter Drive Pulley
- 16 mm (0.625 in) Diameter Idler Pulley
- 8 mm (0.31 in) Diameter Nose Bar Option
- (3) FDA Approved Belt Options: Low, Medium, & High Friction
- M5 Drop in T-Nuts Available
- 25 mm (1 in) & 51 mm (2 in) UHMW Guides

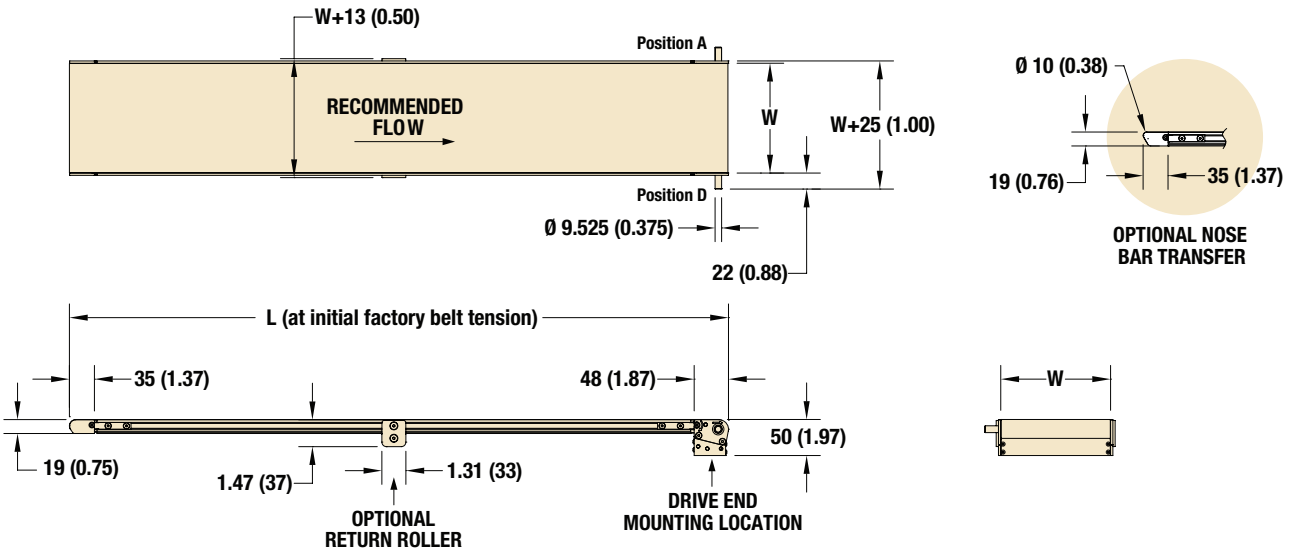

Note: Conveyor with side mount must be mounted at drive end location.

### Standard Sizes

Conveyor Width Reference	02	04	06	08	10
Conveyor Belt Width (W)	44 mm (1.75 in)	95 mm (3.75 in)	152 mm (6 in)	203 mm (8 in)	254 mm (10 in)
Conveyor Length Reference	88	0001 increments up to...			600
Conveyor Length (L)	268 mm (0.88 ft)	3mm (0.12 in) increments up to...			1,829 mm (6 ft)

### Drive Shaft Position

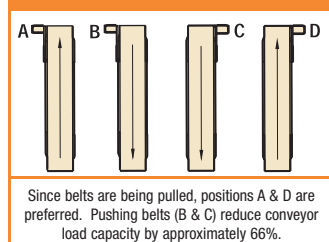

For part number information, see page 6



Type 1 Mount



Type 2 Mount

## Specifications

- Loads up to 6.8 kg (15 lbs)
- Belt Speeds up to 21 m/min (80 ft/min)
- Belt Widths: 44 mm (1.75 in), 95 mm (3.75 in), 152 mm (6 in), 203 mm (8 in), & 254 mm (10 in)
- Conveyor Lengths: 283 mm (11.13 in) to 1,829 mm (72 in) in 3 mm (1/8 in) Increments
- 32 mm (1.25 in) Diameter Mid Drive Pulley
- 16 mm (0.625 in) Diameter Idler Pulleys
- 8 mm (0.31 in) Diameter Nose Bar Option One or Both Ends
- (3) FDA Approved Belt Options: Low, Medium, & High Friction
- M5 Drop in T-Nuts Available
- 25 mm (1 in) & 51 mm (2 in) UHMW Guides

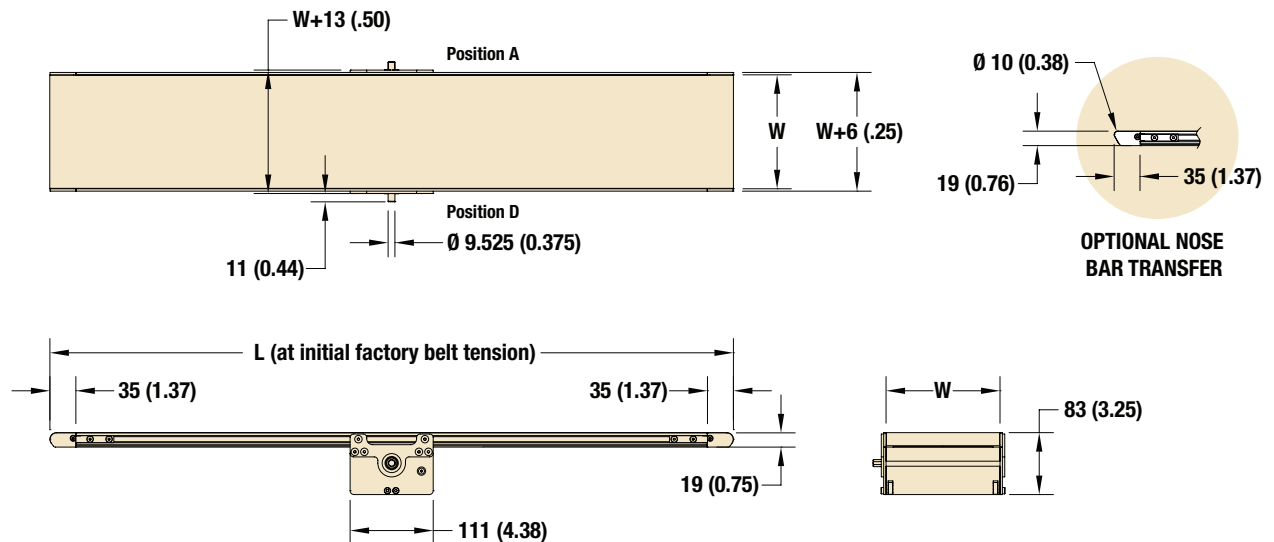

Standard Sizes					
Conveyor Width Reference	02	04	06	08	10
Conveyor Belt Width (W)	44mm (1.75 in)	95mm (3.75 in)	152mm (6 in)	203mm (8 in)	254mm (10 in)
Conveyor Length Reference	93	0001 increments <b>up to...</b>			600
Conveyor Length (L)	283mm (0.93 ft)	0.12 in (3mm) increments <b>up to...</b>			1,829mm (6 ft)

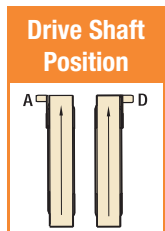

For part number information, see page 6

## Part Number Reference

**1100 Series Flat Belt End Drive Conveyor**

1 M W W E - L L L L 5 0 0 A 0 1 0 1 B B

**Belt Type:** 73 = Low friction, 74 = Medium friction, 19 = High friction

**Profile (D side):** 01 = Low side, 21 = 25 mm (1 in) high side, 22 = 51 mm (2 in) high side

**Profile (A side):** 01 = Low side, 21 = 25 mm (1 in) high side, 22 = 51 mm (2 in) high side

**Drive Shaft Position:** A, B, C or D

**Idler Tail Type:** 0 = Standard idler tail, 1 = Nose bar idler tail

**Drive Tail Type:** 0 = Standard idler tail, 1 = Nose bar idler tail, 2 = End drive tail

**Mounting Bracket Options:**

- 1 = Short mounting brackets
- 2 = Long mounting brackets
- 3 = Long pivoting mounting brackets
- 4 = No mounting brackets or return rollers
- 5 = Short mounting brackets with return roller
- 6 = Long mounting brackets with return roller
- 7 = Long pivoting mounting brackets with return roller
- 8 = Return rollers

**Conveyor Length Reference:** 0088 to 0600

**Drive Type:** E = End Drive  
1 = Mid Drive (motor below drive box)  
2 = Mid Drive (motor to the side of drive box)  
3 = Mid Drive Box Only

**Conveyor Width Reference:** 02 to 10

**Documentation Language:** M = US, U = CE English (can only be DC with Drive Board Only Option)

## Profiles

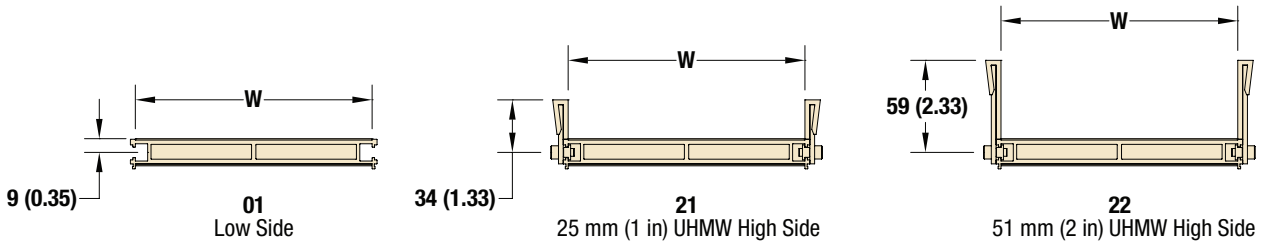

## Standard Belt Selection Guide

Standard belt material is stocked at Dornier, then cut & spliced at the factory for fast conveyor shipment.

Belt Type	Belt Specifications	Thickness	Surface Material	Maximum Part Temperature	Coefficient of Friction	FDA Approved	Anti-Static	Static Conductive	Chemical Resistance*	Special Characteristics or Applications
19	High Friction	0.02 in (0:6)	Smooth Urethane	212°F (100°C)	High	x	x		Good	Product incline or decline
73	Low Friction	0.03 in (0:9)	Carcass Urethane	212°F (100°C)	V-Low	x	x		Good	Product accumulation
74	Medium Friction	0.03 in (0:8)	Smooth Urethane	212°F (100°C)	Medium	x	x		Good	General purpose product movement

Dim = mm (in)

\* Note: See page 13 for detailed Chemical Resistance data.

## Belt Speed

Fixed Speed (115V Single Phase)					
End Drive Conveyor		Mid Drive Conveyor		Gearmotor Chart	
Belt Speed m/min	Belt Speed Ft/min	Belt Speed m/min	Belt Speed Ft/min	RPM From Gearmotor	Part Number
1.5	5.0	1.9	6.2	19	11M075PL411FN
3.2	10.5	4.0	13.1	40	11M036PL411FN

Variable Speed (Brushless DC)					
End Drive Conveyor		Mid Drive Conveyor		Gearmotor Chart	
Belt Speed m/min	Belt Speed Ft/min	Belt Speed m/min	Belt Speed Ft/min	RPM From Gearmotor	Part Number
0.4 - 10.0	1.3 - 32.8	1.6 - 40.9	0.5 - 12.5	125	11M020PLBDDEN
0.6 - 13.4	1.8 - 43.8	2.2 - 54.6	0.7 - 16.7	167	11M015PLBDDEN
0.8 - 20.1	2.6 - 65.5	3.3 - 81.8	1.0 - 25.1	250	11M010PLBDDEN

## Side Mount End Drive

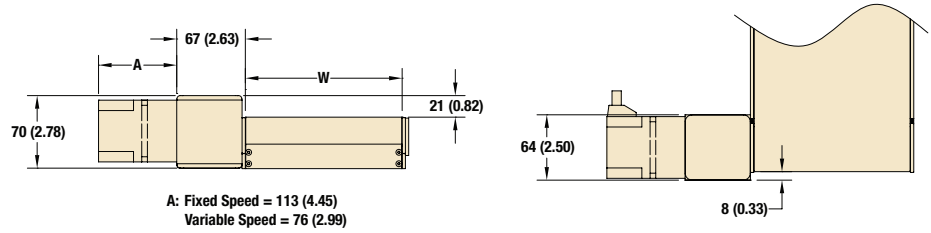

- Includes gearmotor mounting bracket, coupling, coupling guard and mounting hardware

**Note:** Conveyor with side mount must be mounted at drive end location. See page 15 for details.

## Bottom Mount End Drive

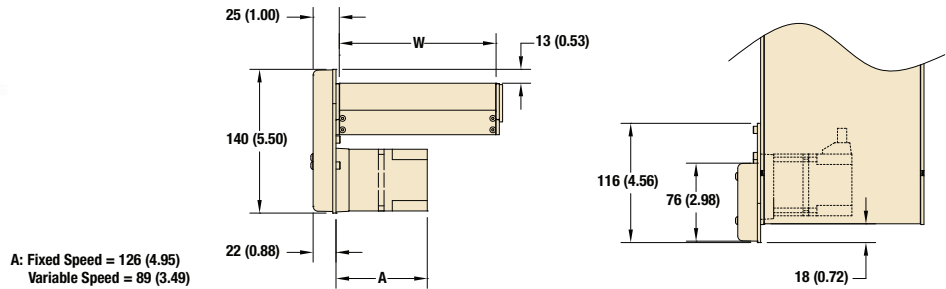

- Includes gearmotor mounting bracket, coupling, coupling guard and mounting hardware

## Type 1 Mid Drive

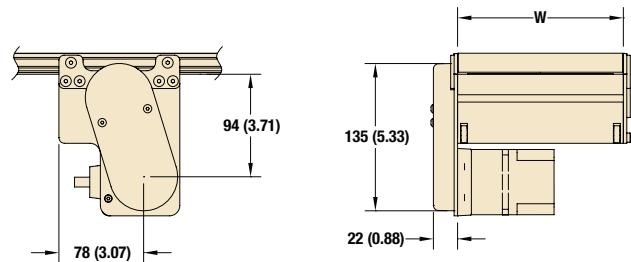

- Includes gearmotor mounting bracket, coupling, coupling guard and mounting hardware

## Type 2 Mid Drive

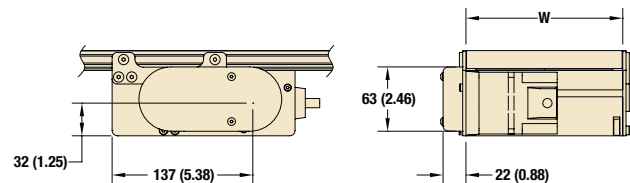

- Includes gearmotor mounting bracket, coupling, coupling guard and mounting hardware

### 1100 Series: Drive Mount Package



1	M	E	2	A
— Drive Shaft Position: A, B, C or D				
— Motor Mount Position: 1 = Type 1 (motor below drive box), 2 = Type 2 (motor to side of drive box)				
— Drive Type: E = End Drive, M = Mid Drive				
— Documentation Language: M = US				

**W** = Conveyor Belt Width    **Dim** = mm (in)



**Note:** Conveyor and gearmotor are not included in the mounting package and must be ordered separately.

**Note:** Due to the wide variety of drive set ups and applications, point of installation guarding is the responsibility of the end user.

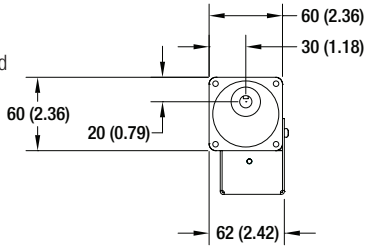
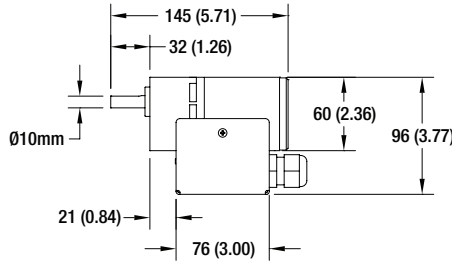
## Fixed Speed

Chart 1		Parallel Shaft					Regulatory Approvals c   
<ul style="list-style-type: none"> <li>Sealed gearmotor</li> <li>Totally enclosed non ventilated</li> <li>Includes switch, cord and overload protection</li> <li>115 V, 1 Phase</li> <li>60 Hz</li> <li>Non-reversing</li> </ul>							
Part Number	Min RPM	Gearmotor Type	Hp	kW	in.-lbs.	Nm	
11M075PL411FN	19	L	0.008	0.006	17	1.92	
11M036PL411FN	40	L	0.008	0.006	9	1.02	

## Variable Speed

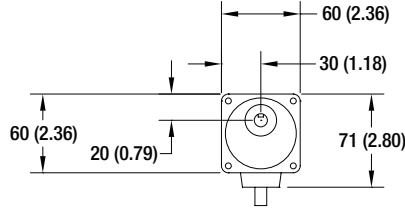
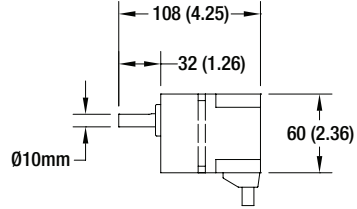
Chart 2		Parallel Shaft					Regulatory Approvals c   
<ul style="list-style-type: none"> <li>Brushless DC</li> <li>Sealed gearmotor</li> <li>Totally enclosed non ventilated</li> <li>Includes cord with plug</li> <li>Index capable up to 60 times per minute</li> <li>Order controller separately, see page 9</li> </ul>							
Part Number	Min RPM	Gearmotor Type	Hp	kW	in.-lbs.	Nm	
11M020PLBDDEN	5	L	0.04	0.003	19.4	2.2	
11M015PLBDDEN	7	L	0.04	0.003	14.1	1.6	
11M010PLBDDEN	10	L	0.04	0.003	9.7	1.1	

## Indexing Repeatability

Brushless DC gearmotors are capable of indexing up to 60 times per minute. Index repeatability is belt speed dependent.

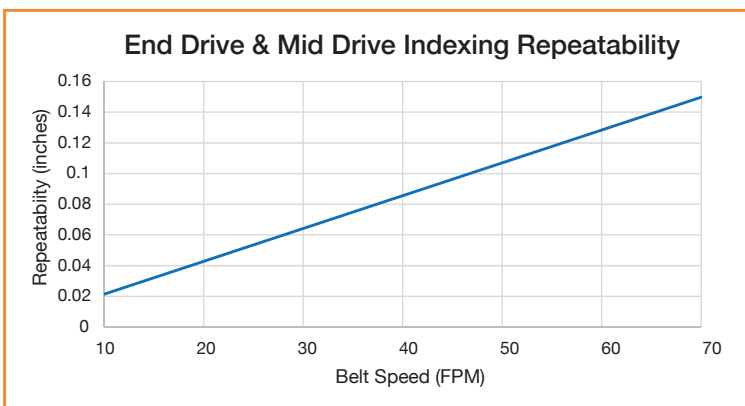

Some motors and gear reducers may normally operate hot to the touch. Consult factory for specific operating temperatures. **Note:** Dimensions = mm (in)

**Note:** Due to the wide variety of drive set ups and applications, point of installation guarding is the responsibility of the end user.

## Variable Speed Controllers

Chart A		Full Feature					
<ul style="list-style-type: none"> <li>• Brushless DC</li> <li>• Nema 1 enclosure</li> <li>• Includes power cord and motor terminal</li> <li>• On/off switch</li> <li>• Speed potentiometer</li> <li>• Forward / reverse switch</li> </ul>						<p><b>Regulatory Approvals</b></p>	
Part Number	Input Volts	Input Phase	Input Hz	Max Input Amps	Output	Max Watts	Reversing
11M11BD-F	115	1	60	1.0	BDC	30	Yes

Note: Regulatory approvals are for components only. This controller assembly has not been submitted or tested against any standards.

Chart B		Remote Signal					
<ul style="list-style-type: none"> <li>• Brushless DC</li> <li>• Nema 1 enclosure</li> <li>• Includes power cord and motor terminal</li> <li>• Access hole with strain relief for remote signal wiring</li> <li>• Remote speed setting</li> <li>• Remote indexing (up to 60 times/min)</li> <li>• Remote forward / reverse</li> </ul>						<p><b>Regulatory Approvals</b></p>	
Part Number	Input Volts	Input Phase	Input Hz	Max Input Amps	Output	Max Watts	Reversing
11M11BD-R	115	1	60	1.0	BDC	30	Yes

Note: Regulatory approvals are for components only. This controller assembly has not been submitted or tested against any standards.

Chart C		Board Level						
<ul style="list-style-type: none"> <li>• Brushless DC</li> <li>• Open board controller</li> <li>• Includes motor terminal</li> <li>• 24VDC</li> <li>• All wiring, enclosure and overloads by others</li> </ul>						<p><b>Regulatory Approvals</b></p>		
Part Number	Input Volts	Input Phase	Input Hz	Rated Input Amps	Max Input Amps	Output	Max Watts	Reversing
11M2DBD-B	24VDC	N/A	N/A	2.1	3.7	BDC	30	Yes

**Note:** Dimensions = mm (in)

**Note:** Due to the wide variety of drive set ups and applications, point of installation guarding is the responsibility of the end user.

## Mounting Brackets

### Horizontal Mounting Bracket

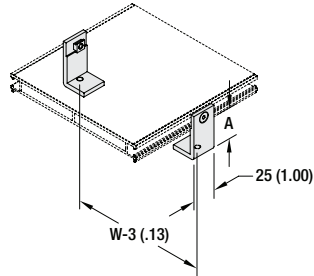

- A:
- 51 mm (2 in) TOB mounting brackets = 30 mm (1.20 in)
  - 83 mm (3.25 in) TOB mounting brackets = 64 mm 2.50 in)
  - Aluminum bracket
  - Includes T-Slot mounting hardware
  - M6 Mounting taps located on lower leg
  - 51 mm (2 in) TOB version matches height of end drive conveyor)
  - 83 mm (3¼ in) TOB version matches height of mid drive conveyor

Part Number	Description
210143	51 mm (2 in) TOB Horizontal Mounting Bracket
210144	83 mm (3¼ in) TOB Horizontal Mounting Bracket

### Pivoting Mounting Bracket

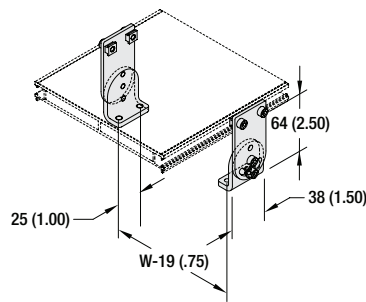

- Stainless Steel bracket
- Includes T-Slot mounting hardware
- M6 Mounting taps located on lower leg
- ± 60 degree angle

Part Number	Description
210149	Pivoting Mounting Bracket

### Return Roller

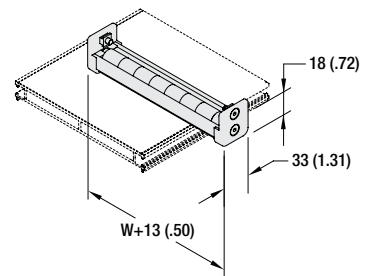

- Plastic mounting bracket
- Includes T-Slot mounting hardware
- Full width 16 mm (5/8 in) diameter plastic rollers

Part Number	Description
210141-WW	Return Roller for 1100 Series, 51 – 254 mm (2 – 10 in) wide

**Note:** Conveyors can be ordered with the required number of mounting brackets. If desired, order additional mounting brackets separately.

## Accessories

### Drop in T-Nuts

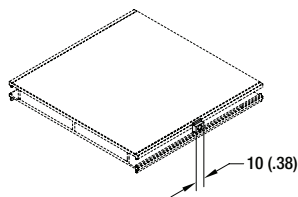

- M5-0.8 Tapped hole
- Zinc plated steel
- Drops into T-Slot
- Package of 5

Part Number	Description
202868	1100 Series M5 Drop in T-Nut (package of 5)

### 3 Jaw Couplings

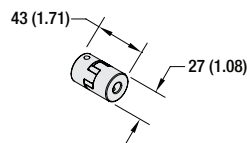

- 3 Jaw Coupling Components
- Compatible with 10 mm (3/8 in) 1100 Series Shafting
- Coupling halves includes set screws
- Rubber spider insert for misalignment

Part Number	Description
11M010	1100 Series Coupling Assembly, 10mm bore
11M375	1100 Series Coupling Assembly, 10 mm (3/8 in) bore

**Note:** Dimensions = mm (in)

**Note:** Due to the wide variety of drive set ups and applications, point of installation guarding is the responsibility of the end user.

**Regulatory Approvals:**







**Conveyors:**

All Dorner 1100 Series standard conveyors (not including gearmotors and controllers) are CE approved. CE approval follows the provisions of the following directives; Machine Directive 2006/42/EC, EU Low Voltage Directive 2006/95/EC, and EMC Directive 2004/108/EC. All conveyors are marked with the CE symbol on the Dorner serial number tag located on the conveyor frame. Contact the factory for the CE Declaration of Conformity.

All Dorner 1100 Series standard conveyors (not including gearmotors and controllers) are designed and manufactured in accordance with the restrictions defined in the “Restriction of Hazardous Substances” directive, citation 2002/95/EC, commonly known as RoHS. All conveyors are marked with the RoHS symbols on the Dorner serial number tag located on the conveyor frame.

**Gearmotors and Controllers:**

All Dorner 1100 Series gearmotors and controllers carry one or more of the following approvals. Products are not covered by each approval. Please see the appropriate part number on the Gearmotor and controller charts located in this manual. In addition, regulatory symbols are located on the product information tags located on the product.

	<p>CE Marking on a product is a manufacturer's declaration that the product complies with the essential requirements of the relevant European health, safety and environmental protection legislation, in practice by the Product Directives. CE Marking on a product ensures the free movement of the product within the European Union (EU).</p>
	<p>This directive restricts (with exceptions) the use of six hazardous materials in the manufacture of various types of electronic and electrical equipment. It is closely linked with the Waste Electrical and Electronic Equipment Directive (WEEE) 2002/96/EC which sets collection, recycling and recovery targets for electrical goods and is part of a legislative initiative to solve the problem of huge amounts of toxic e-waste.</p>
	<p>The UL Recognized Component mark is for products intended to be installed in another device, system or end product. This Recognized Component Mark is for the United States only. When a complete product or system containing UL Recognized Components is evaluated, the end-product evaluation process can be streamlined.</p>
	<p>The UL Recognized Component mark is for products intended to be installed in another device, system or end product. This Recognized Component Mark is for the United States and Canada. When a complete product or system containing UL Recognized Components is evaluated, the end-product evaluation process can be streamlined.</p>
	<p>CSA International (Canadian Standards Association), is a provider of product testing and certification services for electrical, mechanical, plumbing, gas and a variety of other products. Recognized in the U.S., Canada and around the world, CSA certification marks indicate that a product, process or service has been tested to a Canadian or U.S. standard and it meets the requirements of an applicable CSA standard or another recognized document used as a basis for certification.</p>
	<p>The UL Listing Mark means UL found that representative product samples met UL's safety requirements. These requirements are primarily based on UL's own published standards for safety. The C-UL-US Mark indicates compliance with both Canadian and U.S. requirements. The products with this type of Mark have been evaluated to Canadian safety requirements and U.S. safety requirements.</p>

### Clean Room Certifications:

The 1100 Series Conveyors are often used in clean room applications where the generation of particulates from the conveyor are a concern. In these applications the correct installation and application of the conveyor is critical to the proper running of the conveyor and minimizing the dust generated by the conveyor belt or modular belt. The end user must ensure that the conveyor belts are properly tracked and product accumulation is minimized to provide minimal dust generation.

All of the 1100 Series products are designed and constructed to be used in clean room environments. The 1100 Series products have gone through third party testing and certification and are certified for use in ISO Standard 14644-1 Class 5 and Federal Standard 209 Class 100 Clean Room applications.

Contact the factory for copy of the certification.



---

### Materials and Chemical Resistance:

The 1100 Series Conveyors are designed to run in clean, dry environments. Any chemicals introduced to the application must be minimal and the conveyor cleaned on a regular basis. Chemical exposure should be limited to minimal exposure on the belt surface only. Excessive chemicals/debris will cause the conveyor pinch drive system to malfunction. Contact factory for added information.

## Belting:

The following is a list of the top coat materials used in 1100 Series conveyor belting:

Material	Belt Number
Urethane	01, 19, 73, 74

## Resistance to Materials: Belting

The following table provides the resistance to belt materials used in the conveyor to several chemicals. Application testing is recommended to determine long term material durability.

**Legend:** 1 = Good resistance | 3 = Limited resistance | 4 = Not recommended

Materials	Urethane	Materials	Urethane	Materials	Urethane
<b>Chemicals</b>		Carbon disulphide	4	2-Ethyl hexanol	1
Acetic acid (glacial acetic acid)	4	Carbon tetrachloride	3	Formaldehyde	1
Acetic acid 10 %	3	Chlorine, liquid	4	Formic acid, dilute	4
Acetic anhydride	3	Chlorine, gaseous, dry	4	Glycerine	1
Acetone	4	Chlorine, gaseous, wet	4	Glycerine, aqueous	1
Aluminium salts	1	Chlorine water	4	Glycol	1
Alum	1	Chlorobenzene	4	Glycol, aqueous	1
Ammonia, aqueous	3	Chloroform	4	Heptane	1
Ammonia, gaseous	1	Chlorosulphonic acid	4	Hexane	1
Ammonium acetate	1	Chromic acid	4	Hydrochloric acid, conc.	3
Ammonium carbonate	1	Chromium salts	1	Hydrochloric acid 10 %	3
Ammonium chloride	1	Chromium trioxide	1	Hydrofluoric acid 40 %	4
Ammonium nitrate	1	Citric acid	4	Hydrogen chloride, gaseous, dilute	3
Ammonium phosphate	1	Copper salts	1	Hydrogen chloride, gaseous, conc.	3
Ammonium sulphate	1	Cresols	3	Hydrogen peroxide 10%	3
Amyl alcohol	1	Cresols, aqueous	3	Hydrogen sulphide	3
Aniline	3	Cyclohexane	4	Iron salts (sulphate)	1
Barium salts	1	Cyclohexanol	4	Isooctane	1
Benzaldehyde	4	Cyclohexanone	4	Isopropyl alcohol	1
Benzine (see also Motor fuels)	1	Decahydronaphthalene	4	Lactic acid	1
Benzoic acid	1	Dibutyl phthalate	3	Magnesium salts	1
Benzol	3	Diethyl ether	4	Mercury	1
Boric acid	1	Dimethyl formamide	4	Mercury salts	1
Boric acid, solution	1	1.4 Dioxan	4	Methyl alcohol, aqueous 50 %	3
Bromine	4	Ether	4	Methyl alcohol (methanol)	1
Bromine water	4	Ethyl acetate	4	Methyl ethyl ketone	4
Butane, gaseous	1	Ethyl alcohol, non-denatured 100%	1	Methylene chloride	4
Butane, liquid	1	Ethyl alcohol, non-denatured 96%	1	Naphthalene	3
Butyl acetate	4	Ethyl alcohol, non-denatured 50%	1	Nickel salts	1
n-Butyl alcohol	1	Ethyl alcohol, non-denatured 10%	1	Nitric acid	4
Calcium chloride	1	Ethyl benzene	4	Nitrobenzene	4
Calcium nitrate	1	Ethyl chloride	4	Octane (see also isooctane)	1
Calcium sulphate	1	Ethylene chloride	4	Oleic acid	1

## Resistance to Materials: Belting (continued)

The following table provides the resistance to belt materials used in the conveyor to several chemicals. Application testing is recommended to determine long term material durability.

**Legend:** 1 = Good resistance | 3 = Limited resistance | 4 = Not recommended

Materials	Urethane	Materials	Urethane	Materials	Urethane
Oxalic acid	1	Sodium sulphite	1	Cresol solution	3
Ozone	1	Sodium thiosulphate (fixing salt)	1	Diesel oil	1
Perchloroethylene	4	Stearic acid	1	Fertilizer salts	1
Phenol	3	Succinic acid	1	Fixing salt	1
Phenol, aqueous	4	Sulphur	1	Floor wax	1
Phosphoric acid 85 %	4	Sulphur dioxide	3	Formalin	1
Phosphoric acid 50 %	1	Sulphuric acid 96%	4	Fuel oils*	1
Phosphoric acid 10 %	1	Sulphuric acid 50%	4	Furniture polish*	1
Phosphorus pentoxide	1	Sulphuric acid 25%	4	Gypsum	1
Potash lye 50 %	4	Sulphuric acid 10%	4	Ink*	1
Potash lye 25 %	4	Tartaric acids	1	Linseed oil	1
Potash lye 10 %	4	Tetrachloroethane	4	Litex (styrene)	4
Potassium carbonate (potash)	1	Tetrachloroethylene (perchloroethylene)	4	Mineral oils (non-aromatic)	1
Potassium chlorate	1	Tetrahydrofuran	4	Moth balls	3
Potassium chloride	1	Tetrahydronaphthalene	4	Diesel oil*	1
Potassium dichromate	1	Thiophene	4	Petrol (gasoline) DIN51635	1
Potassium iodide	1	Tin II chlorides	1	Petrol, regular	1
Potassium nitrate	1	Toluene	4	Petrol, super	3
Potassium permanganate	1	Trichloroethylene	4	Motor oils*	1
Potassium persulphate	1	Urea, aqueous	1	Oil no. 3 (ASTM)	1
Potassium sulphate	1	Water	1	Oleum	4
Propane, gaseous	1	Xylene	4	Paraffin	1
Propane, liquid	1	Zinc salts	1	Paraffin oil	1
Pyridine	4			Petroleum	1
Silver salts	1	<b>Products</b>		Petroleum ether	1
Soda lye 50% (see potash lye)	4	Alum	1	Photographic developer	1
Soda lye 25%	4	Anti-freeze*	1		
Soda lye 10%	4	Aqua regia	4		
Sodium bisulphite	1	Asphalt	1		
Sodium carbonate (natron)	1	Battery acid	4		
Sodium carbonate (soda)	1	Benzine	1		
Sodium chlorate	1	Bleaching lye (12.5%)	1		
Sodium chloride (common salt)	1	Bone oil	1		
Sodium hydroxide (caustic soda)	4	Borax	1		
Sodium hypochlorite	1	Brake fluid* Bosch	1		
Sodium nitrate	1	Brake fluid* Skydrol	4		
Sodium nitrite	1	Chloride of lime (aqueous suspension)	1		
Sodium perborate	1	Chlorine (active)	4		
Sodium phosphate	1	Chrome baths* (technical)	1		
Sodium sulphate (Glauber salt)	1	Chromosulphuric acid	4		
Sodium sulphide	1				

**Bearings and Lubrication:**

All bearings on the 1100 Series conveyor are sealed and lubricated for life. No grease zerk is available and no greasing over the life of the product is required.

All gearmotors used on the 1100 Series conveyor are sealed and may be mounted in any position. Changing gear oil lubrication may be needed over the life of the gearbox. Please check the appropriate gearmotor manual for instructions.

**Bottom Mount Support Stand Locations:**

Support Stand Locations		
Symbol	Description	Value, inches mm (in)
A	Maximum distance back at drive end	152 (6)
B	Maximum distance back at idler end	305 (12)
C	Maximum distance between supports	914 (36)

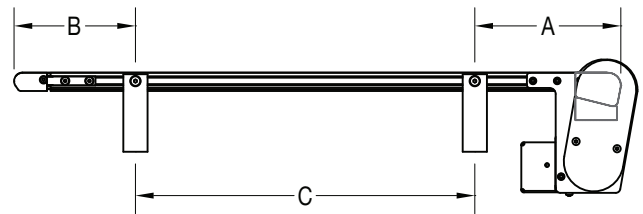

**Side Mount Support Stand Locations:**

Support Stand Locations		
Symbol	Description	Value, inches mm (in)
B	Maximum distance back at idler end	305 (12)
C	Maximum distance between supports	914 (36)

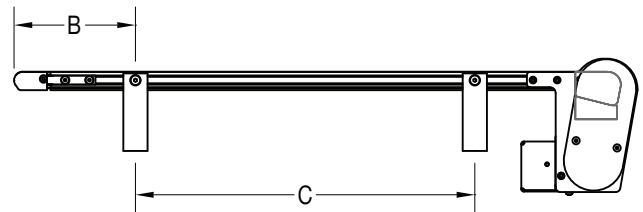

**Note:** Conveyor with side mount must be mounted at drive end location.

**Conveyor Drive Shaft Tolerances:**

**End Drive:**

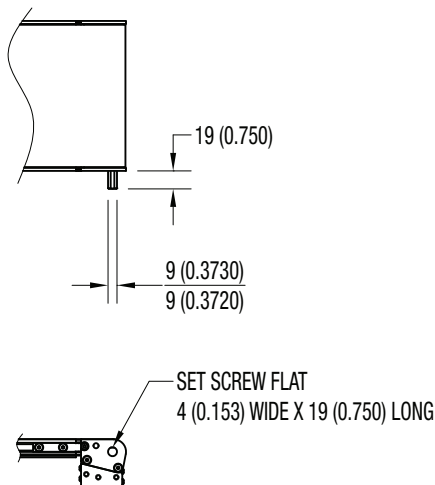

**Mid Drive:**

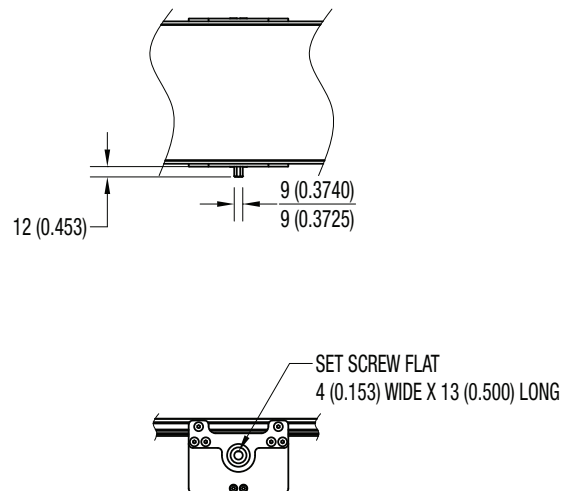

**Note:** Dimensions = mm (in)

## Conveyor Noise Level (Decibel Ratings)

The actual noise level generated by the conveyor depends on several factors; the installation configuration, the product running on the conveyor, the surrounding equipment, the conveyor options and belt speed. The noise level generated by the conveyor is typically less than the general noise level of factory equipment.

Generally a higher belt speed will result in a higher noise level. The following charts provide basic decibel ratings for typical conveyor arrangements.

### Belted Conveyors:

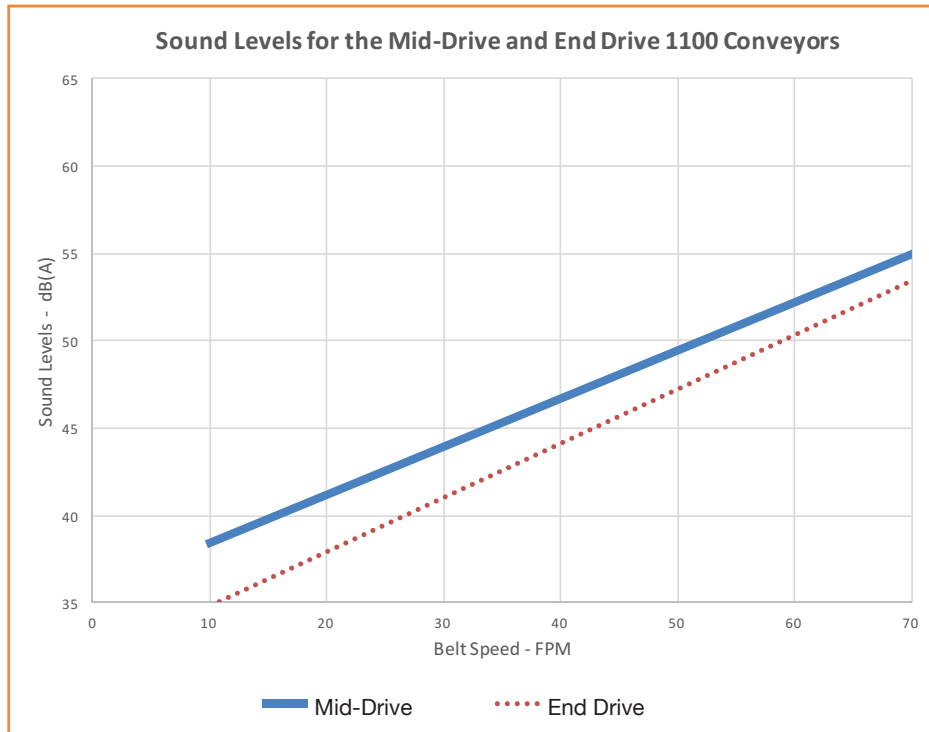

### Maximum Load Capacity

The following Load Capacity Charts **do not** take into account the conveyor configuration, length or gearmotor selection. Your specific conveyor may not be capable of the maximum load condition. Please confirm your maximum load per application with the Dorner DTools program at [www.dornerconveyors.com](http://www.dornerconveyors.com).

All load capacities shown are non-accumulated, evenly distributed loads.

1100 Series End Drive Belted Conveyor		
Belt Width mm (in)	Direction 1, Pulling the Belt kg (in-lbs)	Direction 2, Pushing the Belt kg (in-lbs)
51 (2) wide	3.6 (8)	3.6 (8)
102 (4) wide	5.4 (12)	5.4 (12)
152 (6), 203 (8), 254 (10) wide	6.8 (15)	6.8 (15)

1100 Series Center Drive Belted Conveyor		
Belt Width mm (in)	Direction 1, Pulling the Belt kg (in-lbs)	Direction 2, Pushing the Belt kg (in-lbs)
51 to 254 (2 to 10) wide	6.8 (15)	6.8 (15)

### No Load Torque

No load torque is the amount of torque required to turn an empty conveyor. The torque value varies by conveyor length and configuration. The following charts provide basic values for an average length conveyor. Your specific conveyor may not have a higher value. Please confirm your no load torque and maximum load per application with the Dorner DTools program at [www.dornerconveyors.com](http://www.dornerconveyors.com).

Belted Conveyor No Load Torque		
Belt Width mm (in)	End Drive kg (in-lbs)	Mid Drive kg (in-lbs)
51 (2)	2.3 (5)	3.1 (7)
102 (4)	2.7 (6)	3.6 (8)
152 (6)	3.1 (7)	4.1 (9)
203 (8)	3.6 (8)	4.5 (10)
1254 (10)	4.1 (9)	5.0 (11)

### Belting and Coefficient of Friction

The coefficient of friction is used to determine the load a conveyor can carry. It affects a conveyor in two ways: the friction that exists between the conveyor belt and the bed surface, and if accumulating, product the friction that exists between the conveyor top surface and the product.

Coefficient of Friction, between the bottom of the conveyor belt and bed surface			
Product	Surfaces	Application Condition	Coefficient of Friction
1100 Series Belted	Impregnated polyester fabric to anodized aluminum bed plate	Dry	0.33

#### Coefficient of Friction, between the top surface of conveyor belt and product:

1100 Series Belted		
The following table provides the coefficient of friction between steel product and various belt top surfaces. All factors below are assuming dry conditions.		
Belt Number	Top Surface Material and Type	Coefficient of Friction
74	Smooth medium urethane	0.50
19	Glossy soft urethane	>1.0, do not accumulate
73	Impregnated polyester fabric	0.20

## Calculating Conveyor Belt Speed

### 1100 Series Belted Conveyors:

To calculate the conveyor belt speed you need to know the following factors:

- Drive roller diameter
  - 25mm (1 in) for end drives
  - 32mm (1.25 in) for mid drives
- RPM of gearmotor

$$\text{Belt Speed (ft/min)} = (\text{Drive roller diameter}/12) * (3.14) * (\text{RPM of gearmotor})$$

Example:

1100 Series End Drive with a bottom mount. The gearmotor is a 15:1 ratio Brushless DC gearmotor with 167 rpm output.

$$\text{Belt Speed (ft/min)} = (1/12) * (3.14) * (167)$$

$$\text{Belt speed (ft/min)} = 43.7 \text{ ft/min}$$

## Calculating Conveyor Load Capacity

There are several factors that affect the overall conveyor load of the 1100 Series conveyor. These include:

- Conveyor size and configuration
- Conveyor speed
- Application temperature
- Product accumulation
- Number of starts and stops per hour

Located online at [www.dornerconveyors.com](http://www.dornerconveyors.com) is the Dorner conveyor configuration tool, DTools. This tool allows you to configure your conveyor layout and determine the maximum load capacity for the conveyor. It is suggested that this program be used to calculate the conveyor load as the calculation is quite complicated. This configuration program however does not take into account temperature, dirty conditions, and conveyor starts and stops. If these conditions are part of your application please use the load reducing factors as shown below.

$$\text{Maximum Load} = (\text{Load from DTools})(\text{Temperature Factor})(\text{Start/Stop Factor})$$

Temperature Factor		
Ambient temperature can negatively affect the capacity of the conveyor.		
Temperature F	Temperature C	Temperature Factor
-4	-20	1.0
32	0	1.0
68	20	1.0
104	40	0.9
140	60	0.8

Start / Stop Factor	
Frequent Start / Stops of the conveyor can negatively affect the capacity of the conveyor. All start / stop applications must use a soft start mechanism such as a Frequency Inverter with a 1 second acceleration cycle.	
Application Condition	Start / Stop Factor
Continuous Run or 1 start/stop per hour	1.0
Maximum 10 starts/stop per hour	0.83
Maximum 30 starts/stop per hour	0.70
Greater than 30 starts/stop per hour	0.62

**1100 Series Conveyors are best for:**

- Small or Light Weight Product Handling
- Small Part Transfers
- Tray Handling
- Pill Package Handling
- Package Labeling
- Pharmaceutical Applications
- Life Science Applications
- Medical Applications

**Sizes & Measurements**

- Widths: 44 mm (1.75 in), 95 mm (3.75 in), 152 mm (6 in), 203 mm (8 in), & 254 mm (10 in)
- Lengths: 270 mm (10.63 in) to 1,829 mm (72 in) in 3 mm (.125 in) increments

**Loads & Speeds**

- Loads up to 6.8 kg (15 lbs)
- Speeds up to 21 m/min (80 ft/min)

**Belt Types**

- 3 FDA Approved Belt Options:
- Low Friction
  - Medium Friction
  - High Friction

**Guiding**

- UHMW Guides
- 25 mm (1 in)
  - 51 mm (2 in)



**Drives**

Flat Belt End Drives



Side Mount

Bottom Mount

Flat Belt Mid Drives



Type 1 Mount

Type 2 Mount



**Small Part Transfers**

- Flush Frame allows for side transfers
- Optional 8 mm (.3125 in) nose bar on one or both ends

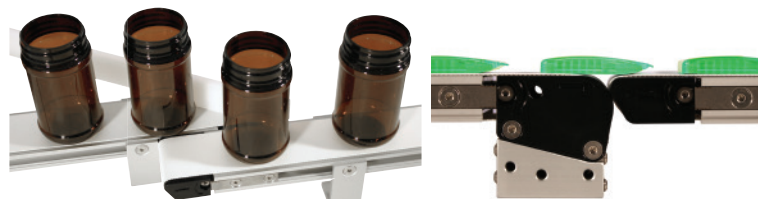

# Industrial & Automation Conveyors

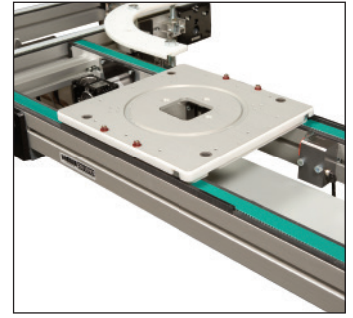
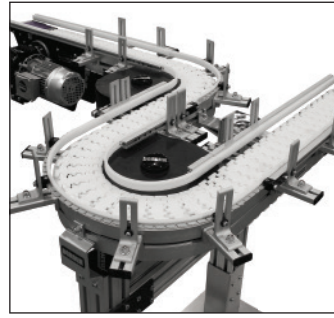
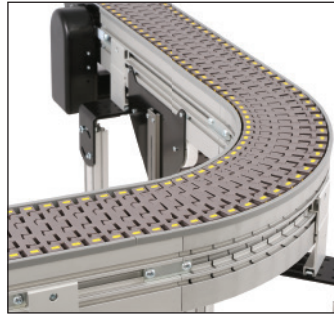

## Sanitary Conveyors

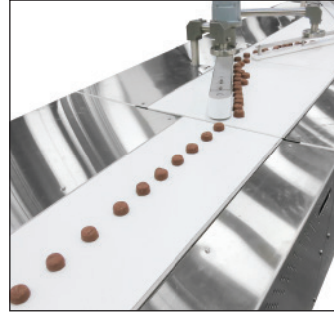
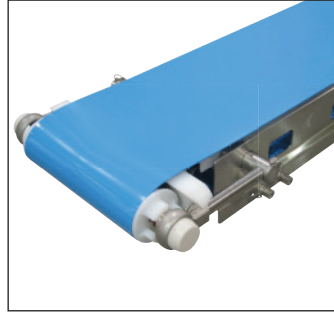
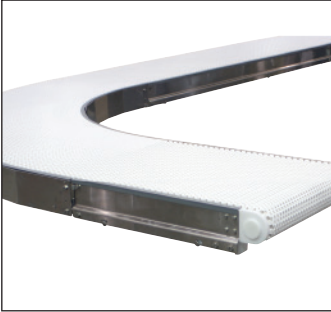

## Engineered Solutions



Parts



Service



Online Configurator



Warranty

# Transforming Conveyor Automation

## Dorner – North & South America

### Dorner – U.S.A.

**Headquarters**  
975 Cottonwood Ave  
Hartland, WI 53029, USA  
(800) 397-8664  
(262) 367-7600  
info@dorner.com

### Dorner – Canada

100-5515 North Service Road  
Burlington, Ontario L7L 6G6  
Canada  
(289) 208-7306  
info@dorner.com

### Dorner – Latin America

Carretera a Nogales #5297,  
Nave 11. Parque Industrial Nogales  
Zapopan, Jalisco C.P. 45222  
Mexico  
+52.33.30037400  
info.latinamerica@dorner.com



## Dorner – Europe

### Dorner – Germany

Karl-Heinz-Beckurts-Straße 7  
52428 Jülich,  
Germany  
+49 (0) 2461/93767-0  
info.europe@dorner.com

### Dorner – France

8-10 Rue de Nieuport  
78140 Vélizy-Villacoublay,  
France  
+33 (0)1 84 73 24 27  
info.france@dorner.com

## Dorner – Asia

128 Jalan Permatang Damar Laut, Bayan Lepas 11960  
Penang, Malaysia  
+604-626-2948 | info.asia@dorner.com

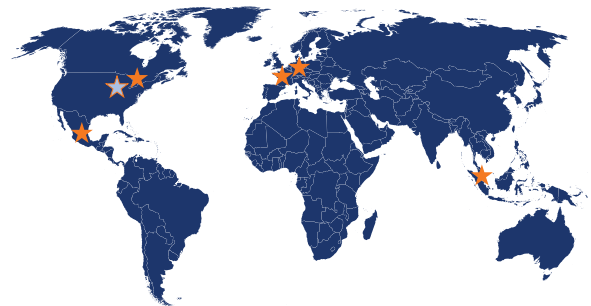

[www.dornerconveyors.com](http://www.dornerconveyors.com)