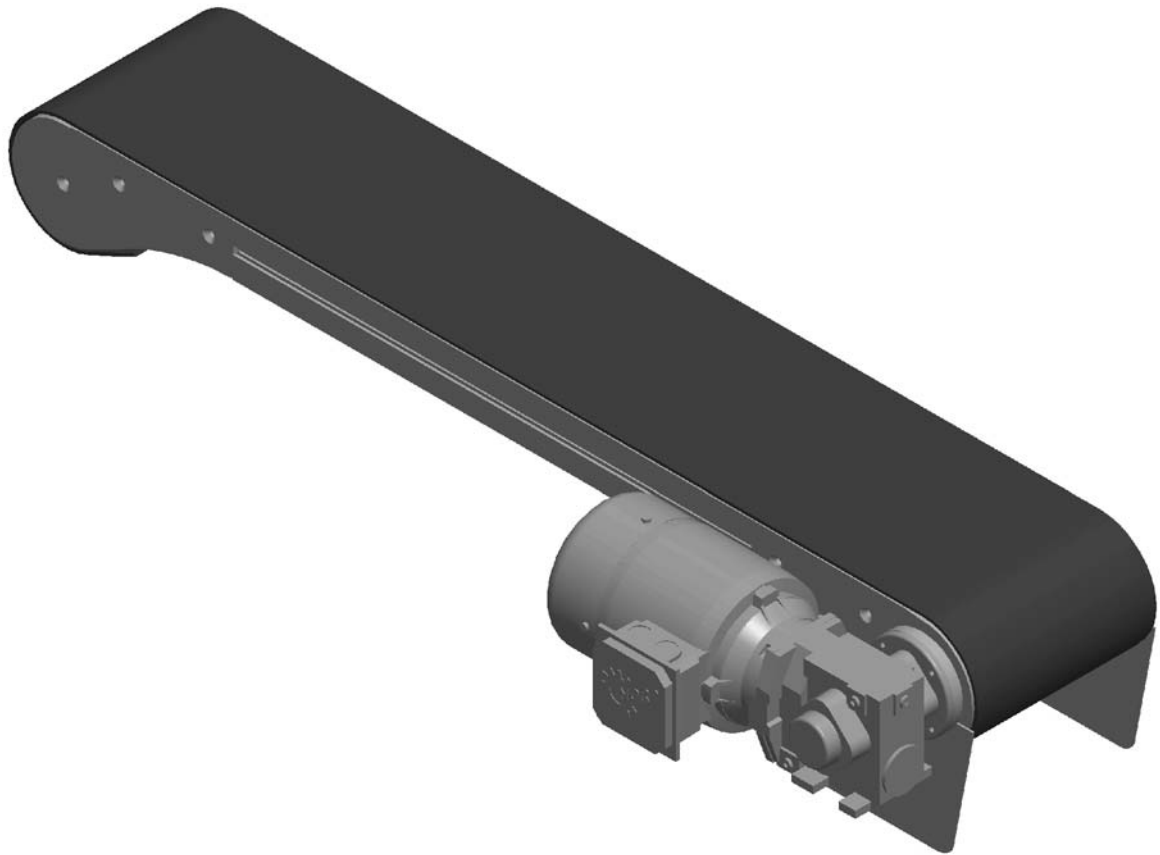




# FlexMove FV (260 mm) Conveyor System

Installation, Maintenance & Parts Manual



For other service manuals visit our website at:  
[www.dornerconveyors.com/manuals-literature](http://www.dornerconveyors.com/manuals-literature)

Record Conveyor Serial Number Here

# Table of Contents

Introduction .....	4	Weighted Take-Up .....	21
Warnings – General Safety .....	5	Install Guiding .....	22
Product Description .....	6	Length Adjustment of the Conveyor Chain .....	22
Specifications .....	7	End Drive Units and Catenary Drive Units .....	22
Conveyor Supports: .....	7	Intermediate Drive Units and	
Maximum Distances: .....	7	Horizontal Bend Drive Unit .....	22
Installation .....	8	Guide Rail System Installation .....	23
Introduction .....	8	High Side Guiding .....	23
Document Disposition .....	8	Heavy Duty Fully Adjustable Guiding .....	24
Initial Assembly Planning .....	8	Puck/Pallet Guiding .....	25
Safeguarding .....	8	Adjustable Guide Rail Bracket .....	26
Considerations .....	8	Assembly with Different Guide Rail Support .....	26
End Drive Unit .....	8	FGRF- 42x18V Guide Rail Bracket Assembly .....	27
Idler Unit .....	8	Assembly with Different Guide Rail Support .....	27
Catenary Drive Unit .....	8	FGRF- 42x18V Spacer Assembly .....	28
Assembly Order .....	8	FGRB- 40x18, FGRB- 40x20 and	
Tools General .....	8	FGRB- 40x15x20 Guide Rail Bracket Assembly .....	28
Tools .....	8	Method 1 .....	28
Hand Tools .....	9	Assembly with Different Guide Rail Support .....	29
Power Tools .....	9	Method 2 .....	29
Fasteners .....	9	Fixed Guide Rail Bracket Installation .....	30
Standard Fasteners .....	9	Guide Rail Connecting Installation .....	30
Square Nut .....	9	Rail Connecting .....	30
Spring Nuts .....	9	Connecting Plug .....	30
Connecting Strip .....	9	Guide Rail Cover Installation .....	31
T-Bolt .....	10	Final Preparations .....	31
Pre installation Information .....	10	Plug Beam Ends .....	31
Cutting FlexMove Beam .....	10	Anchor Feet to the Floor .....	31
Saw Requirements .....	10	Other Preparations .....	31
Working Site .....	10	Start-Up and Testing .....	31
Quality of Cut .....	10	Safety Considerations .....	31
Assembly .....	10	Safeguarding can be achieved by: .....	32
Foot Installation .....	11	Torque Limiter Adjustment	
Conveyor Installation .....	12	for Suspended Drive Units .....	32
Option 1 .....	12	Introduction .....	32
Option 2 .....	12	Name of Parts .....	32
Option 3 .....	12	Torque Setting .....	32
Mounting Conveyor Beam Support Bracket .....	12	Replace the Friction Facing .....	32
Conveyor Beam Installation .....	13	Maintenance and Precautions	
Drive Unit and Idler End Unit Installation .....	14	after the Replacement Procedure .....	32
Drive End .....	14	Safety .....	32
Drive Tail Support Brackets .....	14	Preventive Maintenance and Adjustment .....	33
Idler End .....	14	Start-Up and Maintenance Schedule .....	33
Attaching Slide Rail in Straight Beam .....	15	Chain Lubrication .....	33
Slide Rail End Installation at Connector Beam .....	16	Wear .....	33
Slide Rail Installation at Horizontal		Chain Elongation .....	33
Plain Bends and Vertical Bend .....	17	Inspection .....	34
Drilling Slide Rail .....	17	Drive Unit .....	34
Fixing Slide Rail .....	17	Maintenance Schedule .....	34
Nylon Screw .....	17	First 3rd Month, 6th Month, and	
Aluminum Rivet .....	18	Every 6th Month Following .....	34
Checking Slide Rail and Rivet Condition After Fixed ..	18	Checking Slide Rail with the	
Joining Chain End .....	19	Conveyor Chain in Place .....	34
Chain Installation at Drive Unit .....	19	Checks When the Chain is Removed .....	35
Chain Assembly at Chain		Horizontal Bends .....	35
Disconnecting Module FVCC .....	20	Safety Devices .....	35

---

# Table of Contents

---

Troubleshooting.....	36	Flange Mounted Motor (Direct Drive Tail).....	87
Required Tools.....	37	Foot Mounted Motor (Suspended Drive Tail).....	88
Conveyor Chain Replacement.....	37	Slide Rail Replacement Tool.....	89
Replacing a Section or Entire Chain.....	37	Slide Rail.....	89
Conveyor Chain Tensioning.....	38	Replacement Chain.....	89
Slide Rail Replacement.....	38	Belt Removal Tool.....	89
Idler Pulley Replacement.....	38	Side Cutter.....	90
Drive Spindle Shaft Replacement.....	39	Utility Cutter.....	90
Retaining Guide Replacement.....	41	Bearing Tool.....	90
Cantenary Drive End.....	41	Notes.....	91
Idler End and GP Drive Tail.....	42	Return Policy.....	92
Gearmotor Drive.....	43		
Weighted Take-Up.....	43		
Power Transfer.....	45		
Removal.....	45		
Installation.....	48		
Service Parts.....	52		
Drive Tail.....	52		
Guided Profile (GP) Drive Tail.....	54		
FVSD-A260 Suspended Drive.....	56		
Weighted Take-Up.....	58		
Idler Tail.....	60		
Frame Assembly.....	61		
Curve Frame Assembly.....	62		
Knuckle Frame Assembly.....	63		
#4 & #5 High Sides for Straight Modules.....	64		
#4 & #5 High Sides for Curve Modules.....	65		
#4 & #5 High Sides for Incline/Decline Modules.....	66		
#13 & #14 Heavy Duty Fully Adjustable Guiding.....	67		
#17 & #18 - Puck / Pallet Guiding.....	68		
Type A - Fixed Guiding (16x54).....	69		
Type B - Fixed Guiding (16x42).....	69		
Type C - Fixed Guiding (28x42).....	70		
Type D - Fixed Guiding (40x42).....	70		
Type E - Fixed Guiding (49x42).....	71		
Type F - Fixed Guiding (53x42).....	71		
Type G - Fixed Guiding (90x42).....	72		
Type H - Adjustable Width Guiding (8x39x45).....	72		
Type J - Adjustable Width Guiding (26x39x45).....	73		
Type K - Adjustable Width Guiding (40x18).....	73		
Type L - Adjustable Height Guiding (18x110).....	74		
Type M - Adjustable Height Guiding (18x150).....	74		
Type N - Fully Adjustable Guiding.....	75		
Type P - Fully Adjustable Guiding.....	75		
Type Q - Dual Rail Guiding.....	76		
Type R - Dual Rail Guiding.....	76		
Type S - Adjustable Height Guiding.....	77		
Driven Bridge.....	78		
Suspended Drive Driven Bridge.....	79		
Power Transfer.....	80		
Horizontal Mounting Brackets.....	81		
Support Post - Conveyor Frame Mount.....	82		
Support Post - Motor Mount.....	83		
Suspended Drive Stand.....	84		
E-Drive Gearmotor Mounting Package.....	85		
Standard Load 90° Industrial Gearmotors.....	86		


---

# Introduction

---

<b>IMPORTANT</b>
------------------

<i>Some illustrations may show guards removed. DO NOT operate equipment without guards.</i>
---

Dorner has convenient, pre-configured kits of Key Service Parts for all conveyor products. These time saving kits are easy to order, designed for fast installation, and guarantee you will have what you need when you need it. Key Parts and Kits are marked in the Service Parts section of this manual with the Performance Parts Kits logo .

Dorner reserves the right to make changes at any time without notice or obligation.

Upon receipt of shipment:

- Compare shipment with packing slip. Contact factory regarding discrepancies.
- Inspect packages for shipping damage. Contact carrier regarding damage.
- Accessories may be shipped loose. See accessory instructions for installation.

Dorner's Limited Warranty applies.

## Warnings – General Safety

### WARNING

The safety alert symbol, black triangle with white exclamation, is used to alert you to potential personal injury hazards.

### DANGER



Climbing, sitting, walking or riding on conveyor will cause severe injury. **KEEP OFF CONVEYORS.**

### DANGER



**DO NOT OPERATE CONVEYORS IN AN EXPLOSIVE ENVIRONMENT.**

### WARNING



Exposed moving parts can cause severe injury. **LOCK OUT POWER** before removing guards or performing maintenance.

### WARNING



Gearmotors may be **HOT**.  
**DO NOT TOUCH** Gearmotors.

### WARNING



Dorner cannot control the physical installation and application of conveyors. Taking protective measures is the responsibility of the user.

When conveyors are used in conjunction with other equipment or as part of a multiple conveyor system, **CHECK FOR POTENTIAL PINCH POINTS** and other mechanical hazards before system start-up.

### WARNING



Loosening stand height or angle adjustment screws may cause conveyor sections to drop down, causing severe injury.

**SUPPORT CONVEYOR SECTIONS PRIOR TO LOOSENING STAND HEIGHT OR ANGLE ADJUSTMENT SCREWS.**

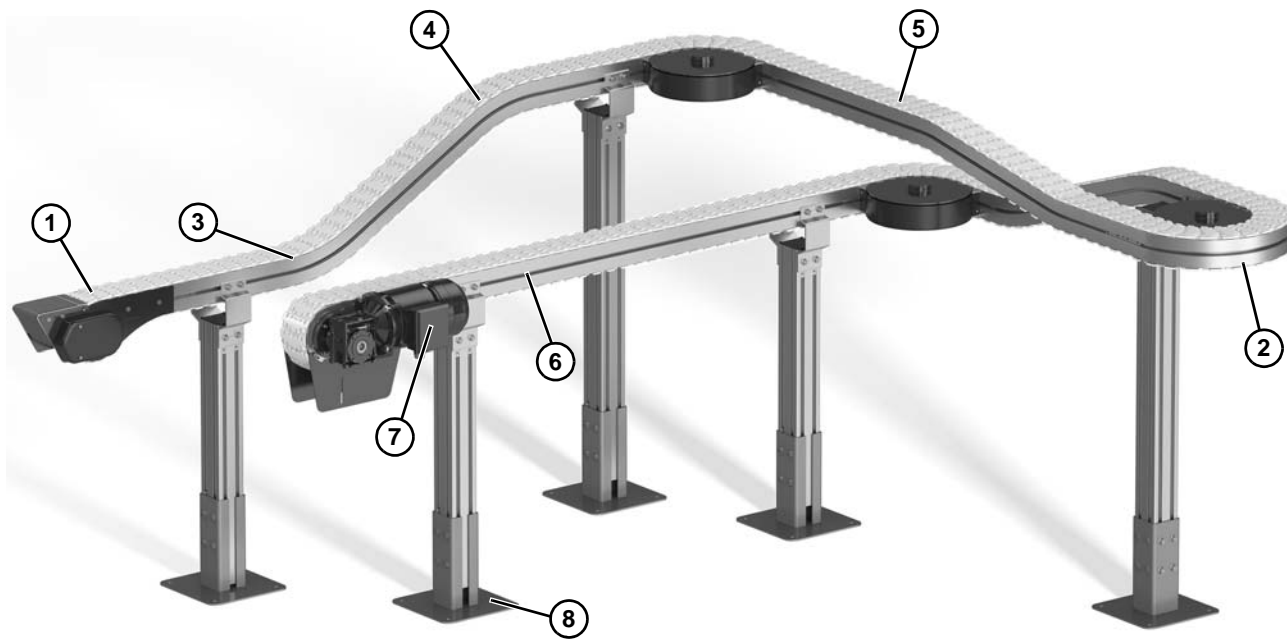
---

# Product Description

---

Refer to **Figure 1** for typical components.

1	Infeed Module
2	Curve Module
3	Incline Module
4	Decline Module
5	Intermediate Module
6	Drive Module
7	Gearmotor
8	Stands



**Figure 1**

## Conveyor Supports:

### Maximum Distances:

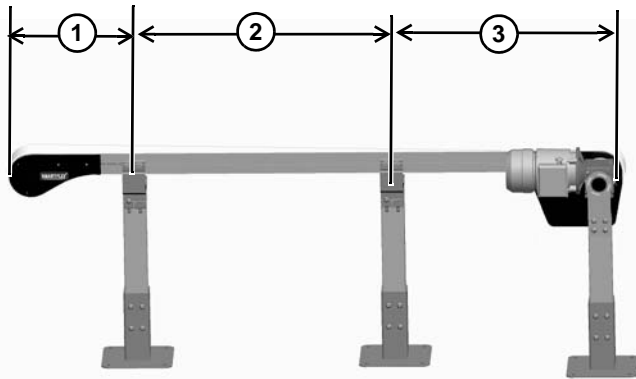
1 = 914 mm (36")

2 = 3000 mm (118")\*

3 = 914 mm (36")

\* For conveyors longer than 3000 mm (118"), install support at joint.

Note: Additional support required on 180° curve modules.



**Figure 2**

---

# Installation

---

## Introduction

The main purpose of this manual is to help self-building end users, with little or no prior experience, to assemble a FlexMove conveyor system. Each chapter includes detailed instructions and pictures showing how to assemble the different parts. Most pictures in the manual include parts from the FS conveyor system, but all instructions are applicable to the FH, FK, FS, FM, FC, FL, FU and FV.

## Document Disposition

The document is divided into the following five main parts:

- Installation site preparations
- Tools and fasteners
- Assembly
- Start-up and testing

## Initial Assembly Planning

Systematically working planning is required:

- Fully understand and studying the assembly drawing.
- Ensure the necessary tools are required.
- Ensure all the parts and materials are well prepared in advance, following the parts list.
- Enough space for conveyor installation is important.
- Ensure the floor is even and so the foot can be properly attached on the floor.

## Safeguarding

All pinch and shear points, as well as other exposed moving parts that present a hazard to users, is recommended to be safe guarded. Cleat conveyor chain is more susceptible of creating pinch and shear points than plain chain.

When two or more pieces of equipment are interfaced, special attention must be given to the interfaced area to ensure proper safeguarding.

For overhead conveyors, guards must be provided if products fall off the conveyor for some reason. The same applies to all incline, decline and vertical conveyors.

## Considerations

When correctly applied, the conveyor components are safe to use or maintain. It is, however, necessary for those responsible to design, installation, operation and maintenance to be aware of certain areas when special caution is required.

## End Drive Unit

The chain slack of a normal direct drive unit must be maintained during the system lifetime.

## Idler Unit

The opening between links (when they turn around idler) could be a potential risk. The idler end should not be accessible during conveyor operation.

## Catenary Drive Unit

The bridge area where the chain goes down should not be accessible during conveyor operation.

## Assembly Order

During the conveyor assembly, the following items can be used as a checklist:

- Cut all beams to desired length.
- Connect all feet and structural beams.
- Mount conveyor beam support brackets.
- Assemble conveyor beams and mount them onto the support structure.
- Mount drive and idler unit at the end of the conveyor.
- Mount slide rail onto the conveyor beam.
- Loosen the slip clutch at the drive unit.
- Check any obstruction of the conveyor with a short piece chain.
- Assemble and mount necessary chain onto the conveyor.
- Mount guide rail and other accessories required onto the conveyor.
- Tighten the slip clutch with suitable friction.
- Read the final preparations at the end of this manual.

## Tools General

### Tools

To assemble a FlexMove Conveyor, you may need most of the tools listed on the following page. Not all are essential, but they will make your work easier and efficient.

## Hand Tools

- Wrench
- Slide rail cutter
- Set of metric hex keys
- Counter sink bit
- Drill fixtures for slide rail
- Riveting tool
- In addition, the tools listed below can be useful:
  - Files
  - Socket wrench
  - Screwdriver
  - Pliers
  - Knife (burr of slide rail)
  - Flush cutting pliers
  - Soft head hammer
  - Chain tools (for chain installation and dismantle)
  - Level

## Power Tools

- Hand drill
- Drill bit (for fixing slide rail)

## Fasteners

### Standard Fasteners

Standard Fasteners (**Figure 3**):

- M8 = Washer, Countersink Cap Screw, Nut, Lock Nut
- M6 = Washer, Countersink Cap Screw, Nut, Lock Nut



**Figure 3**

## Square Nut

Square nuts (**Figure 4**) can be slid into T-slot of FlexMove conveyor and support beams. They do not stay in place in vertical positions and have to be inserted from the end of beam. Remember to put in a sufficient number before completing the assembly.



**Figure 4**

## Spring Nuts

Spring nuts (**Figure 5**) can be inserted into the T-slot of FlexMove conveyors and support beams. They do not stay in place in vertical positions.



**Figure 5**

## Connecting Strip

Connecting strips (**Figure 6**) are used for joining end to end of beams. Use hex key and set screws when attaching the connecting strip to the beam.



**Figure 6**

# Installation

## T-Bolt

T-bolts (**Figure 7**) can be entered from the beam side, and when turned 90 degrees they will stay in place after tightening with lock nuts. Use lock nuts to facilitate T-bolt turning in slot. The indication groove in the T-bolt should be at 90 degrees to the conveyor T-slot. T-bolts are used when attaching support brackets, guide rails and drip trays to the conveyor beam. T-bolts should not be used when fine adjustment for exact positioning is required (use square nuts or spring nuts for this type of application). Do not use T-bolts with support beams.



**Figure 7**

## Pre installation Information

### Cutting FlexMove Beam

Cutting is required for all 3m beams, including a precise cut to 3m lengths. Study your drawing to determine the beam lengths required before cutting.

### Saw Requirements

The circular cross-cut saw used for aluminum profile cutting must be equipped with carbide tip saw circulating at high speed for a clean cut. The saw should have the ability of cutting the largest profile in one single cutting action.

### **⚠ WARNING**

**All safety precautions issued by the cutting saw manufacturer should be followed at all the times.**

### Working Site

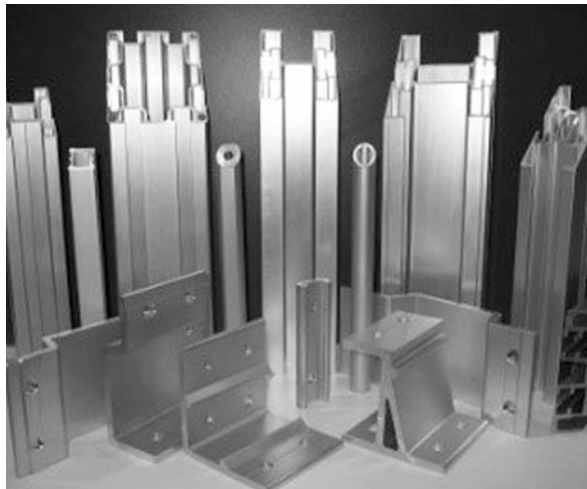
You should use a special area for cutting beams in order to keep the assembly area clean.

### Quality of Cut

If burrs are evident, they must be removed prior to assembly. Make sure the cut is straight for proper assembly.

## Assembly

The basic FlexMove conveyor structure consists of five component groups (See **Figure 8** and **Figure 9**):



**Figure 8**



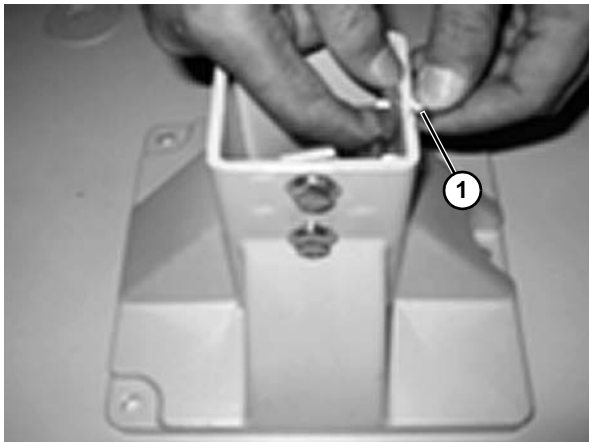
**Figure 9**

- Support structure
- Conveyor beams, straight sections, and bends
- Drive and idler units
- Chains
- Guide rail assembly components
- Other accessories

The first step in the assembly process is to assemble the support structure, which consists of feet, support beams, and beam support brackets. Most conveyor support designs are based on vertical support beams, combined, if necessary, with horizontal support beams. There are also a number of different feet and beam support brackets, so check which ones are suitable to use in your application.

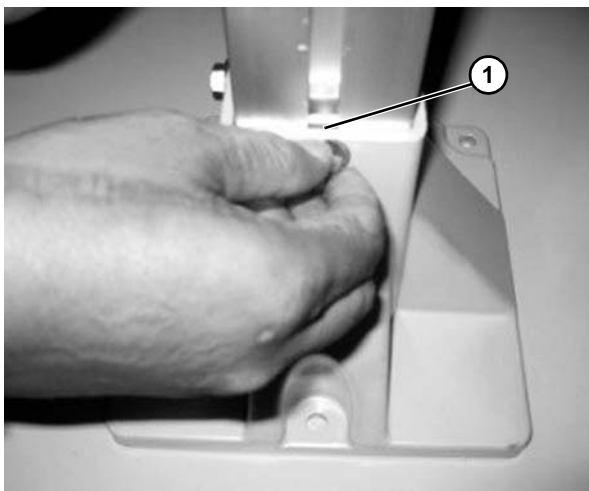
## Foot Installation

1. Insert hex head screws and washers (**Figure 10, item 1**) into the holes on the side of the foot. Use the screws to fasten foot connecting strips to the inner side of the foot. Leave loose.



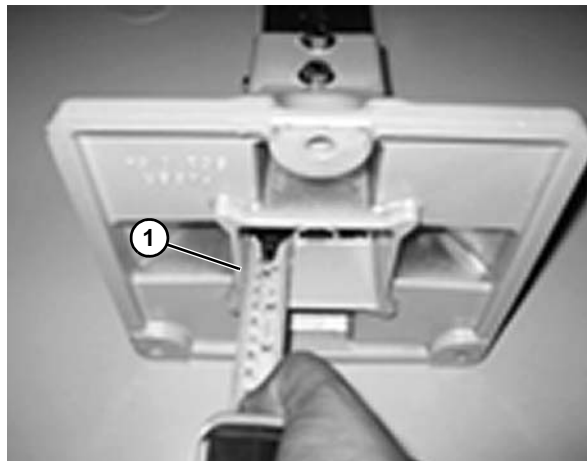
**Figure 10**

2. Slide the connecting strips (**Figure 11, item 1**) into the structural beam T-slots.



**Figure 11**

3. Raise the beam from the bottom of the foot approximately 40-50 mm (**Figure 12, item 1**), to allow for height adjustment later in the assembly.



**Figure 12**

4. Tighten the screws using a wrench (**Figure 13, item 1**).



**Figure 13**

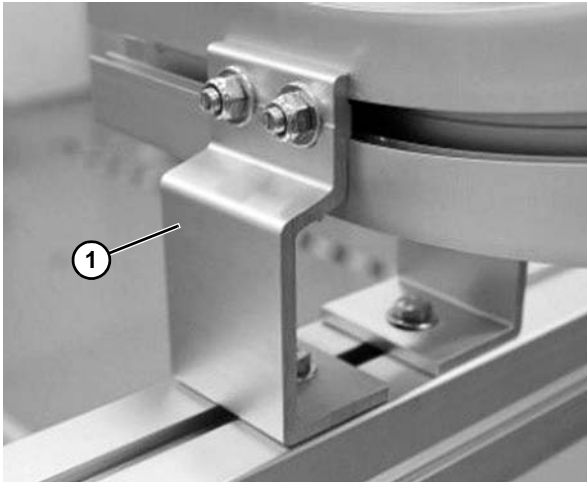
# Installation

## Conveyor Installation

Conveyor beams are mounted on to the support structure by means of support brackets. There are three different types of conveyor beam support brackets. They all serve the same purpose but are connected to the structural beams in different ways.

### Option 1

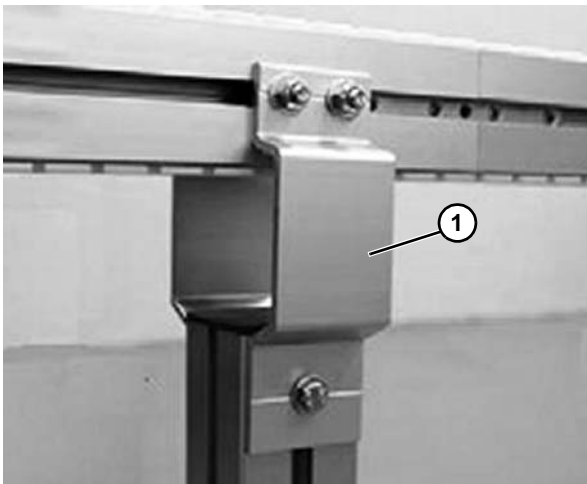
Horizontal beam support brackets (60mm or 80mm) (**Figure 14, item 1**) are used for horizontal support structure mounted to 64x64mm or 80x80mm support beams.



**Figure 14**

### Option 2

Vertical beam support brackets (**Figure 15, item 1**) are used with vertical support beams and are made from aluminum.



**Figure 15**

### Option 3

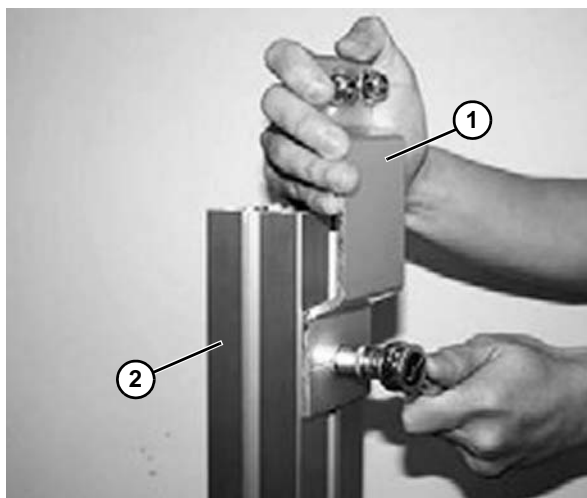
Dual side mounting brackets (**Figure 16, item 1**) are used to support 180° wheel corners.



**Figure 16**

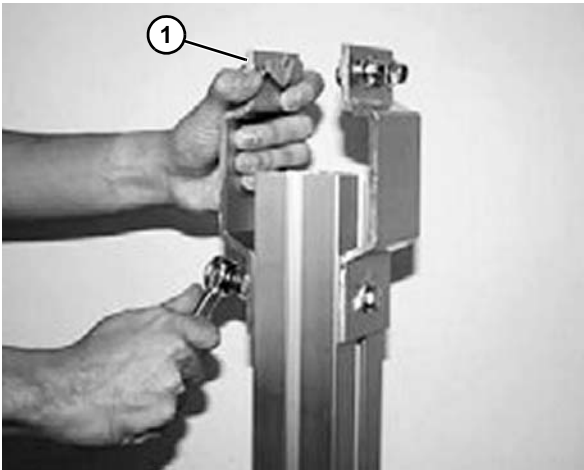
## Mounting Conveyor Beam Support Bracket

1. Attach screws, nuts and washers to the support bracket (**Figure 17, item 1**) before mounting. (Screws and square nuts are support beam fasteners; T-bolts and nuts are conveyor beam fasteners.) Slide the square nuts of one support bracket into the support beam T-slots. Tighten the screws. Make sure that the support bracket is aligned with the beam cross-section (**Figure 17, item 2**) as shown in the drawing.



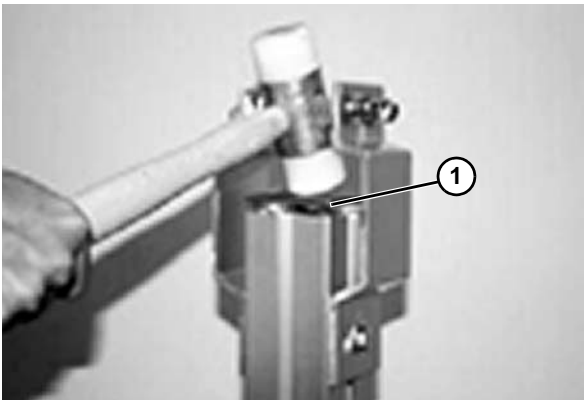
**Figure 17**

2. Insert the square nuts of the second support bracket (**Figure 18, item 1**) into the support beam T-slots. Slide the bracket down so that it does not protrude above the cross-section of the beam.



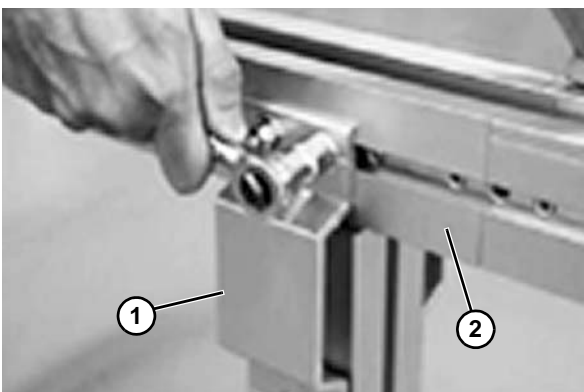
**Figure 18**

3. Use a soft hammer or mallet to mount an end cap (**Figure 19, item 1**) on to the support beam.



**Figure 19**

4. Mount the first support bracket (**Figure 20, item 1**) to the conveyor beam (**Figure 20, item 1**). Pull the second bracket up and insert the T-bolts into the conveyor beam T-slot. Tighten the nuts.

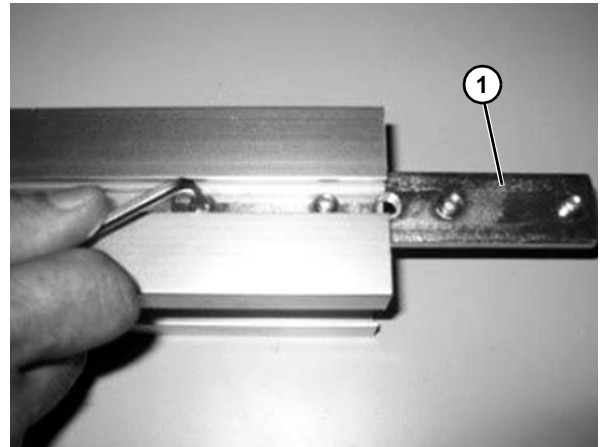


**Figure 20**

## Conveyor Beam Installation

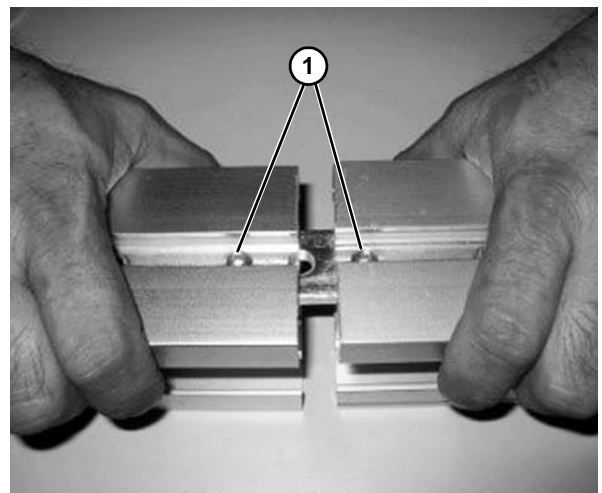
The next step is to connect conveyor beams – straight sections and bends – to each other. Connect all conveyor beams according to the instructions below.

1. Connect two conveyor beam ends by inserting connecting strips (**Figure 21, item 1**) into the beam inner T-slots. Use two connecting strips per beam joint.



**Figure 21**

2. Make sure that the set screws (**Figure 22, item 1**) do not prevent the connection strips from sliding into place.



**Figure 22**

# Installation

3. Tighten the set screws using a hex key (Figure 23, item 1).

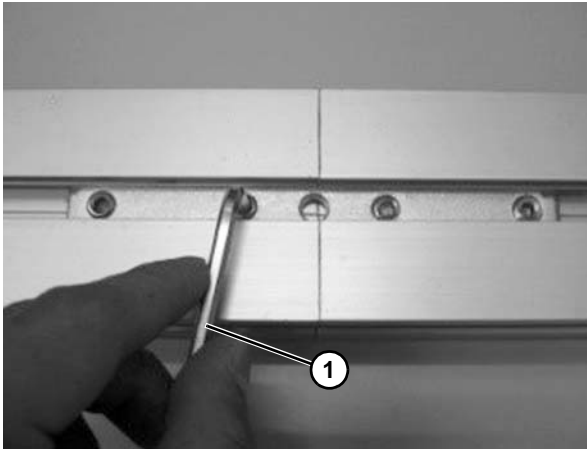


Figure 23

## NOTE

Assemble the entire conveyor beam structure in the same way. If the conveyor beam is too long to mount onto the support structure in one continuous length, assemble shorter lengths and connect them to each other once fastened to the support beams.

2. Tighten the set screws using a hex key (Figure 25, item 1).



Figure 25

## Drive Tail Support Brackets

1. Attach the drive tail support brackets (Figure 26, item 1) to the slot (Figure 26, item 2) in the drive tail with the T-bolts and hex nuts. The brackets should be located closest to the frame (Figure 26, item 3).

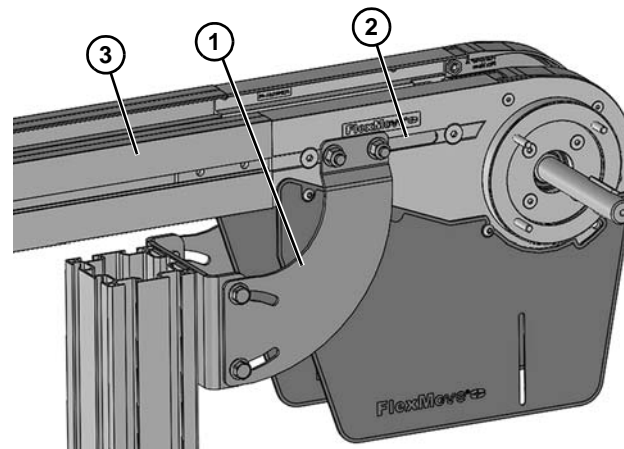


Figure 26

## Drive Unit and Idler End Unit Installation

### Drive End

1. Mount the end drive unit (Figure 24, item 1) on to the end of the conveyor: Release the four set screws that are inserted into the drive unit connecting strips. Insert the connecting strips into the T-slot of the beam you want attached to the end drive unit. Make sure that the set screws do not prevent the connecting strips from sliding into place.

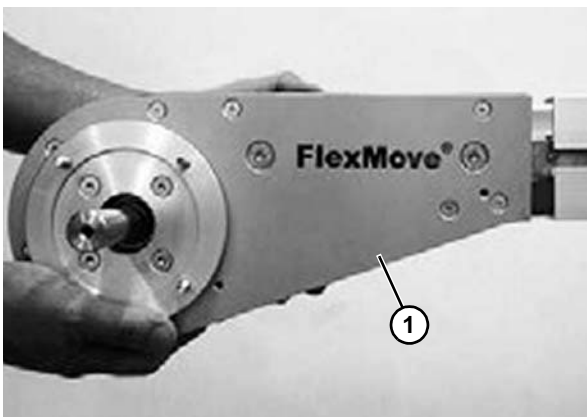


Figure 24

### Idler End

1. Insert the idler unit (Figure 27, item 1) connecting strips into the T-slots of the beam end and tighten it.



Figure 27

2. Tighten the set screws using a hex key (Figure 28, item 1).



Figure 28

## CAUTION

The opening between the links when they turn around the idler could be a risk. Idler ends should not be accessible during conveyor operation.

3. Make sure the slide rail (Figure 31, item 1) is properly mounted and snaps onto the beam. The longer flange of the slide rail must always face inside of the beam (See Figure 32).

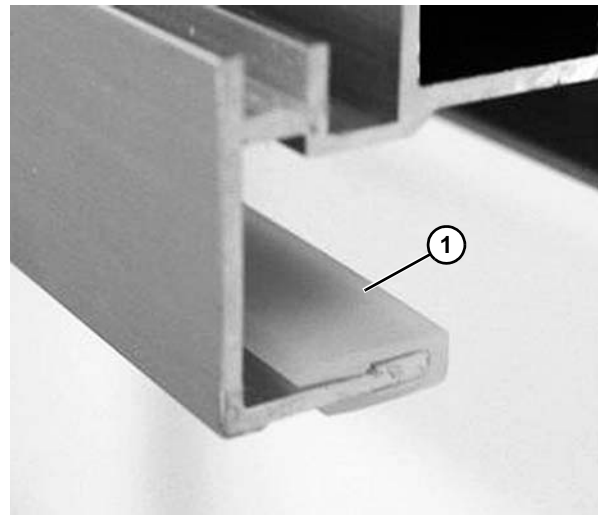


Figure 31

## Attaching Slide Rail in Straight Beam

1. Start the slide rail assembly at an idler end unit (Figure 29, item 1). Separate the top and bottom flange of the slide rail at the end of rail and press into place.

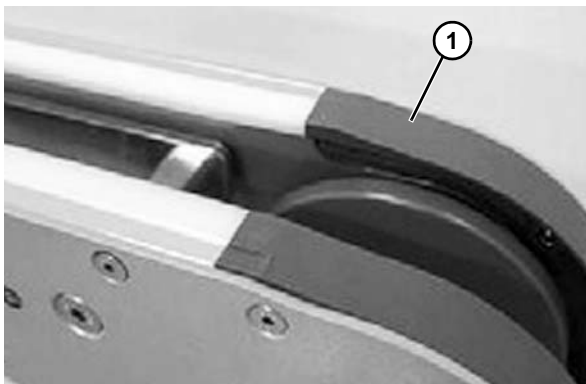


Figure 29

2. Attach the six slide rails onto the conveyor frame in the locations shown in Figure 30.

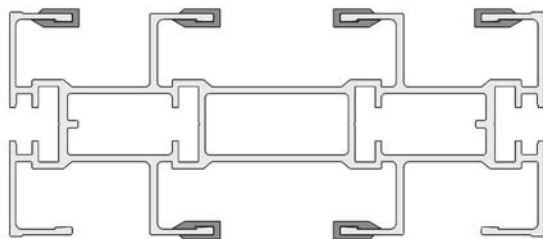


Figure 30

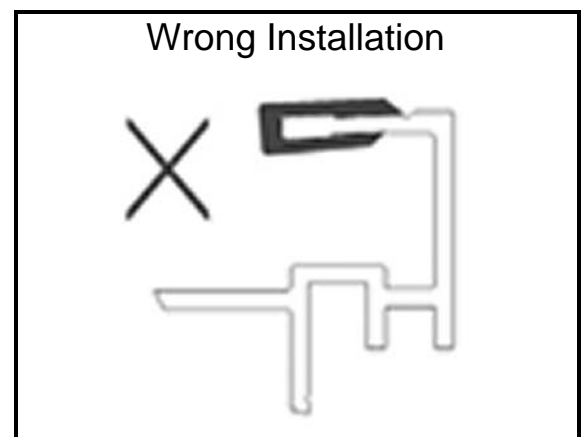
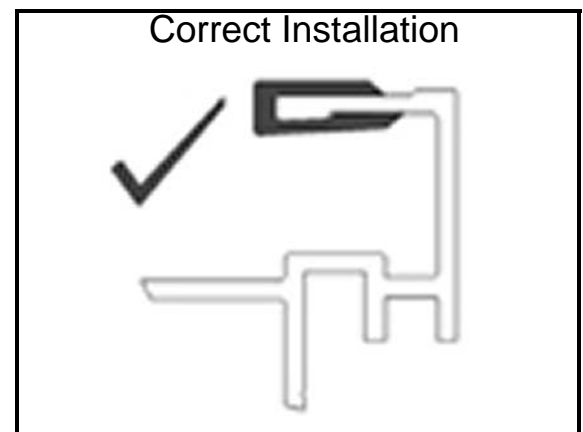
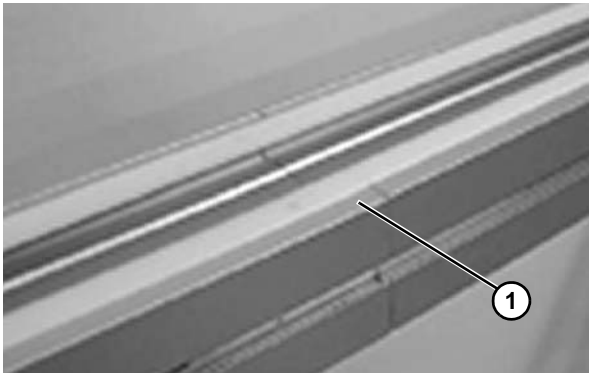


Figure 32

# Installation

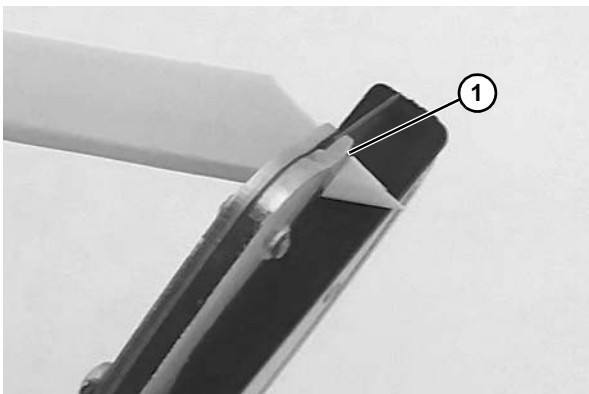
- The slide rail (**Figure 33, item 1**) must be mounted across the entire beam section. Remember to mount slide rails on both top and bottom side of the beam (unless top running chain only).



**Figure 33**

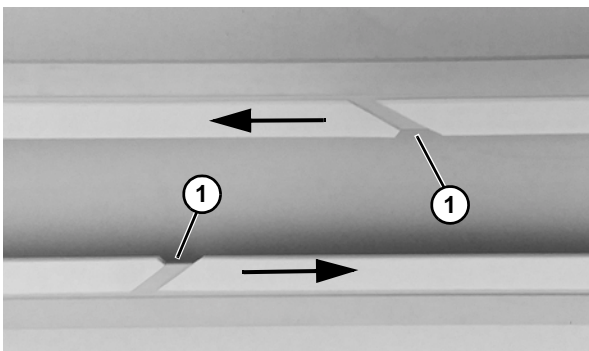
## Slide Rail End Installation at Connector Beam

- Cut both slide rail ends at a 35° angle. The beginning of a new slide rail (in the direction of travel) must cut back at a small angle (**Figure 34, item 1**).



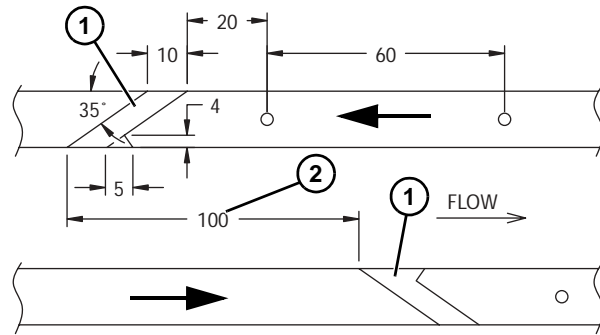
**Figure 34**

- Allow a space of approximately 10 mm (**Figure 35, item 1**) between two slide rail ends. The travel direction is indicated by an arrow.



**Figure 35**

- Do not place two slide rail joints (**Figure 36, item 1**) opposite each other. Make sure there is a distance of at least 100 mm (**Figure 36, item 2**) between them to make the chain run smoother. This does not apply to slide rail that begins by an idler unit or after a drive unit, where joints are always parallel.

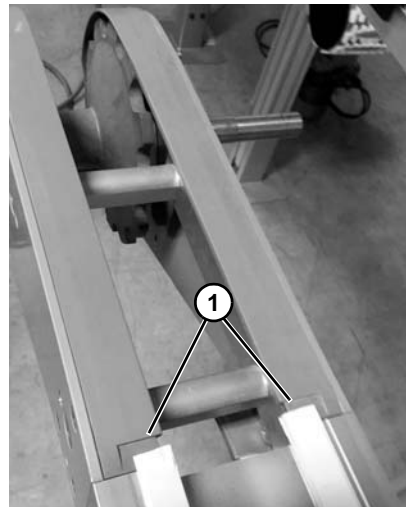


(Dimensions in mm)

**Figure 36**

Try to let the slide rail run in as continuous lengths as possible, up to 5 m lengths, by reducing number of breaks, except in circumstances stated below:

- It is recommended to use short slide rails 2–3m (78-3/4”–118”) where chemicals may have an effect on the slide rail composition.
- It is important to cut the slide rail and allow for elongation in high load areas. Cutting is required in wheel and horizontal bends (see following page), at idler units and where the conveyor will be heavily loaded. This prevents the slide rail from stretching out and entering into the drive unit, which may block the chain movement.
- Never join slide rail in horizontal or vertical bends, since forces are higher on the slide rail in these sections. Instead, place the joint before the bend.
- Avoid slide rail splices on top of conveyor beam joints.
- Allow 5 mm expansion gaps where slide rails end at drive tail top side, idler tail return side, and wheel corner inner rail transitions (**Figure 37, item 1**).



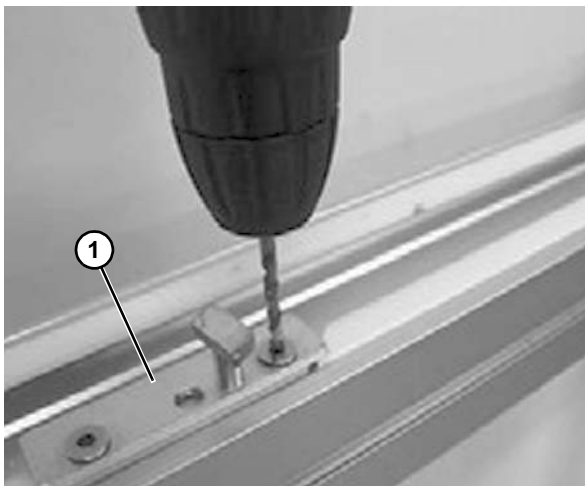
**Figure 37**

## Slide Rail Installation at Horizontal Plain Bends and Vertical Bend

In plain bends with a small radius, the slide rail for the inner bend should be cut so that it is only 10 mm wide in the bend. This is to prevent an uneven slide rail surface. Stretch the slide rail while mounting.

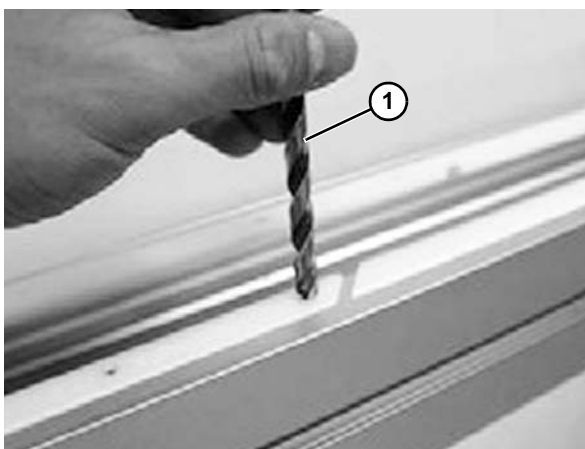
### Drilling Slide Rail

1. Drill two holes near the beginning of each slide rail section. Use the drill fixture (**Figure 38, item 1**) to ensure clean-cut holes and the correct location of the holes. The holes must be at the leading edge of the joint piece, in the direction of travel, to hold the slide rail in place when the conveyor is in use. Use a well sharpened 4.3mm, #18, or 11/64" drill bit.



**Figure 38**

2. Use a bigger drill bit or countersink bit (**Figure 39, item 1**) to deburr and countersink the holes. Also make sure that there are no metal filings left underneath the slide rail.



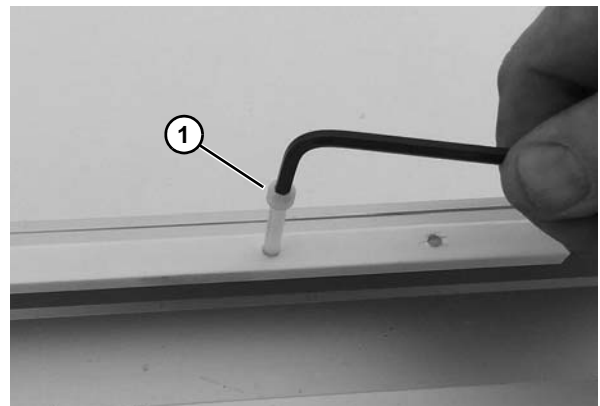
**Figure 39**

### Fixing Slide Rail

The beginning of each slide rail section must be fixed to the beam, since the chain will cause the slide rail to be pushed forward. A slide rail which moves into a drive unit can block the chain completely. The riveting method is more secure if the conveyor will run with high operational speed or be heavily loaded.

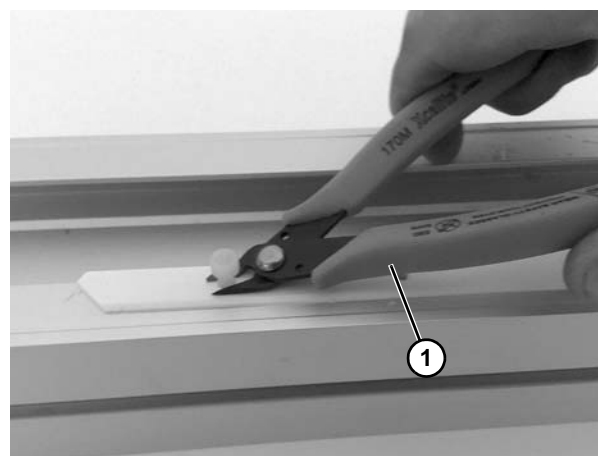
### Nylon Screw

1. Insert the nylon screws (**Figure 40, item 1**) into the holes using a hex driver until the screw is flush with the bottom of the slide rail.



**Figure 40**

2. Cut off the head of nylon screws by using flush cutting pliers (**Figure 41, item 1**) or soft hammer and knife (**Figure 42, item 1**). Remember, the cut must be made away from the joint, in the direction of chain travel.



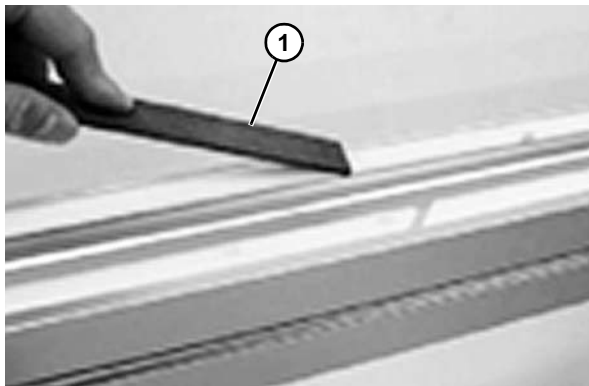
**Figure 41**

# Installation



**Figure 42**

3. After the cut, make sure the slide rail surface is smooth and the nylon screws do not protrude over the slide rail surface. Use a file (**Figure 43, item 1**) to file off the protruding edge if uneven surface is found.



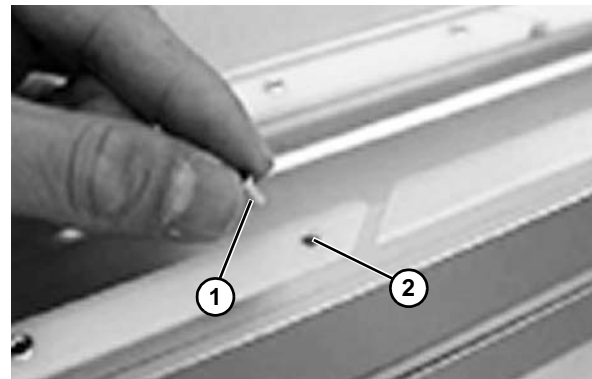
**Figure 43**

## NOTE

*Nylon screws can be used multiple times before being discarded. Ensure bottom of screw is cut square before re-using.*

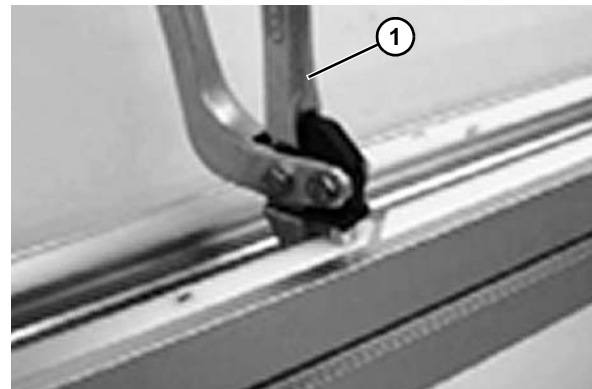
## Aluminum Rivet

1. Insert the aluminum rivets (**Figure 44, item 1**) into the holes (**Figure 44, item 2**).



**Figure 44**

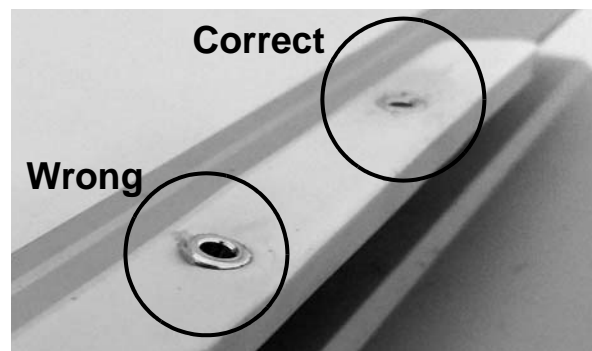
2. Clamp the aluminum rivet by using crimping pliers (**Figure 45, item 1**).



**Figure 45**

## Checking Slide Rail and Rivet Condition After Fixed

1. Ensure slide rails do not protrude due to the over-pressing during rivet process.
2. Check that the rivets do not protrude over the surface of the slide rail. Check both top and underneath surface of slide rail for protruding metal. (See **Figure 46**.)

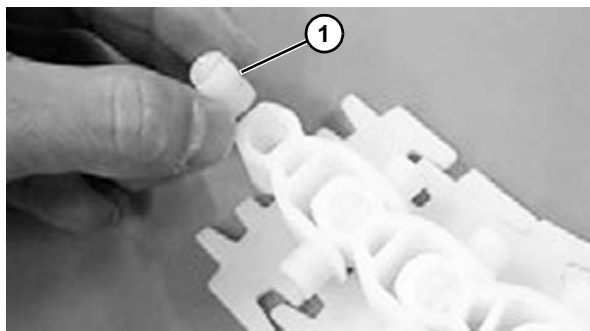


**Figure 46**

## Joining Chain End

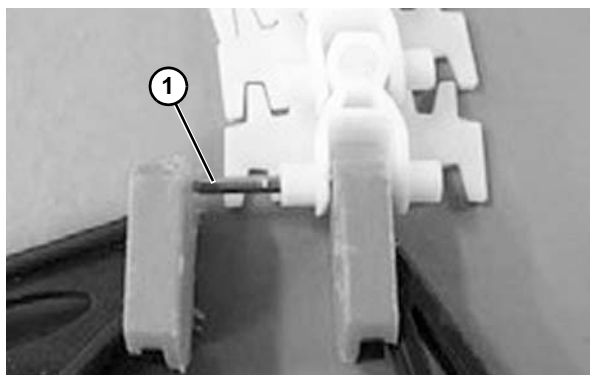
Assemble the chain by inserting the steel pin that comes with each chain link, into the opposite end of another link. Do this by using the FlexMove pin insertion tool.

1. Insert the plastic pivot (**Figure 47, item 1**) with the slot facing outward.



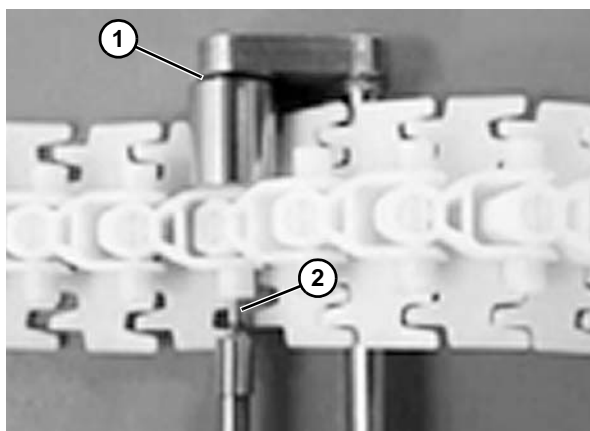
**Figure 47**

2. Insert the steel pin (**Figure 48, item 1**) halfway, using a pair of pliers. Always use new steel pins and plastic pivots when joining chain ends.



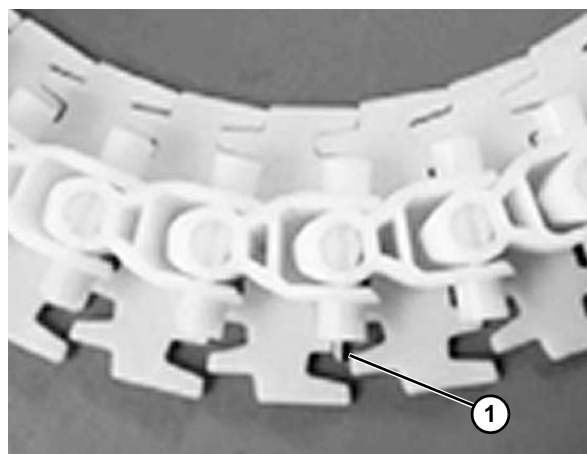
**Figure 48**

3. Line the FlexMove chain tool (**Figure 49, item 1**) up with the pin (**Figure 49, item 2**). Slowly depress the trigger until the pin seats. A slight detent will be felt when pin is seated.



**Figure 49**

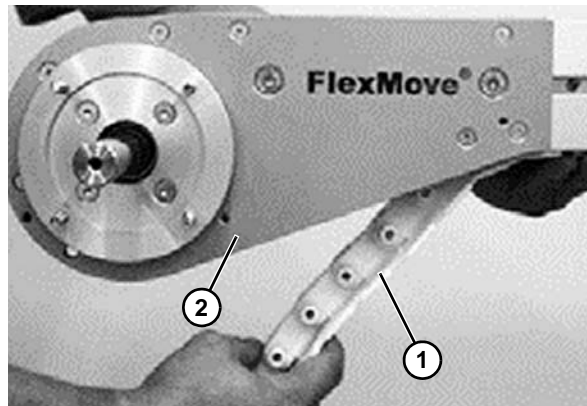
4. Check that the chain is flexible in the joint and that the pin does not stick out or go through the other side (**Figure 50, item 1**).



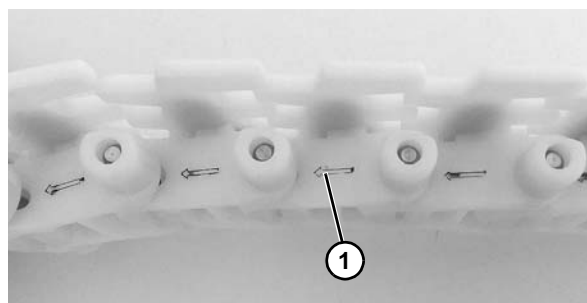
**Figure 50**

## Chain Installation at Drive Unit

1. Insert the chain (**Figure 51, item 1**) into the underside of the drive unit (**Figure 51, item 2**). Make sure the chain will be moving in the correct direction, as indicated by the arrow (**Figure 52, item 1**) located at the side of all chain links.



**Figure 51**



**Figure 52**

# Installation

2. Feed the chain along the conveyor (Figure 53, item 1) by pulling it through the idler unit and back to the drive unit.

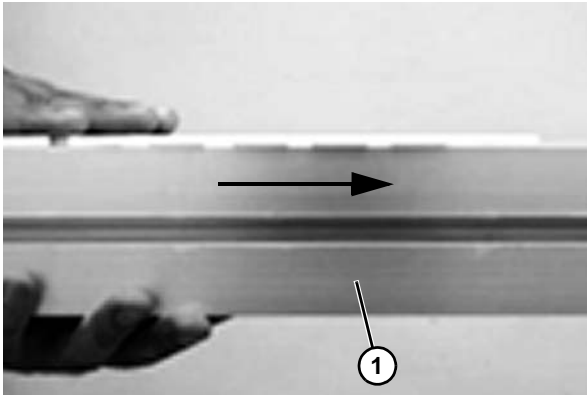


Figure 53

3. Join 5 meter lengths of chain when necessary. (See Figure 54.)



Figure 54

4. Tension the chain and remove links if necessary, so that the chain will exhibit some slack at the drive unit. Put in the stainless steel pin (Figure 55, item 1) at the hole provided at drive unit and join the chain.

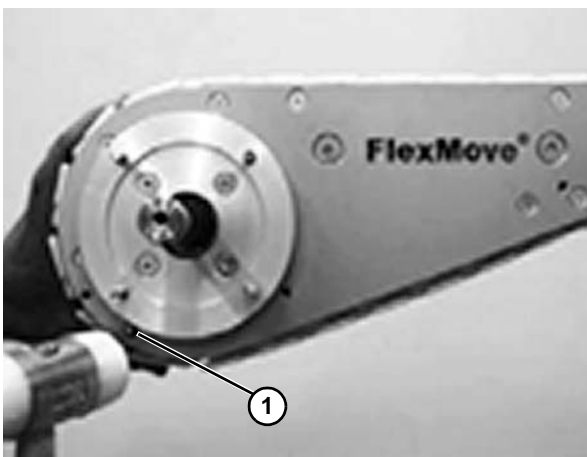


Figure 55

## Chain Assembly at Chain Disconnecting Module FVCC

1. Loosen the screws (Figure 56, item 1) on the beam section flanges.

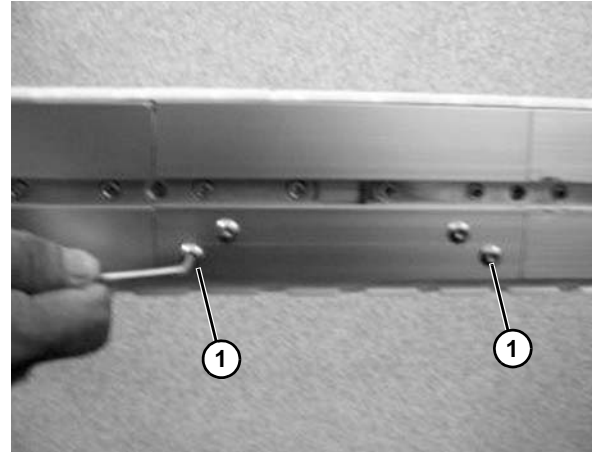


Figure 56

2. Remove the flange (Figure 57, item 1) so that the chain becomes accessible.

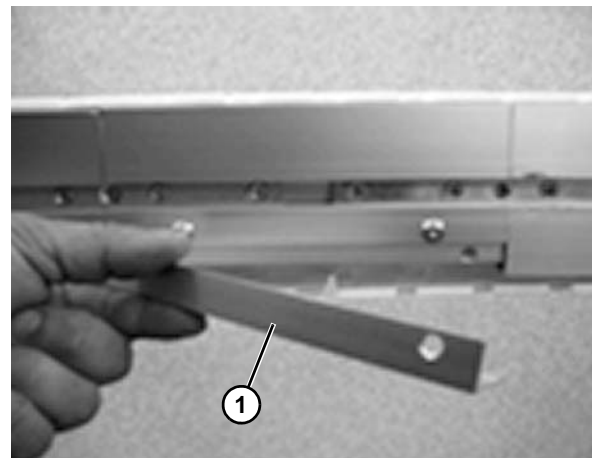
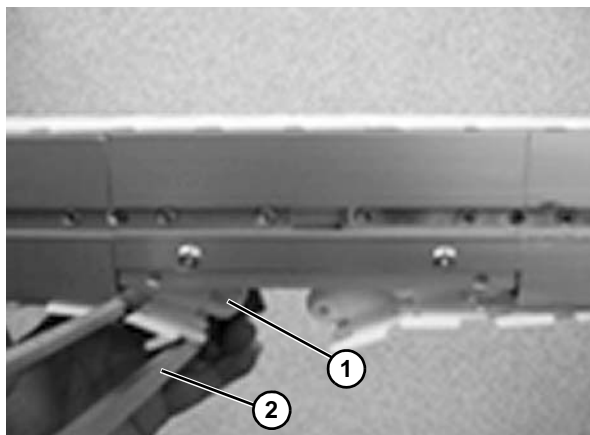


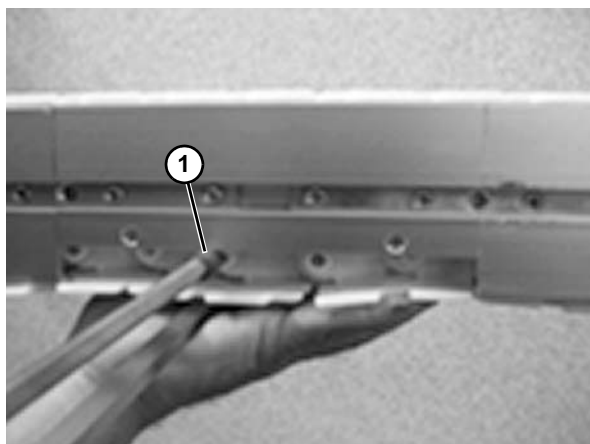
Figure 57

3. Clamp the chain (**Figure 58, item 1**) to the beam profile. Use the FlexMove chain tool (**Figure 58, item 2**) to remove a steel pin from the chain, so that two links are separated.



**Figure 58**

4. Remove excess links and use the chain tool (**Figure 59, item 1**) to put the chain back together again.



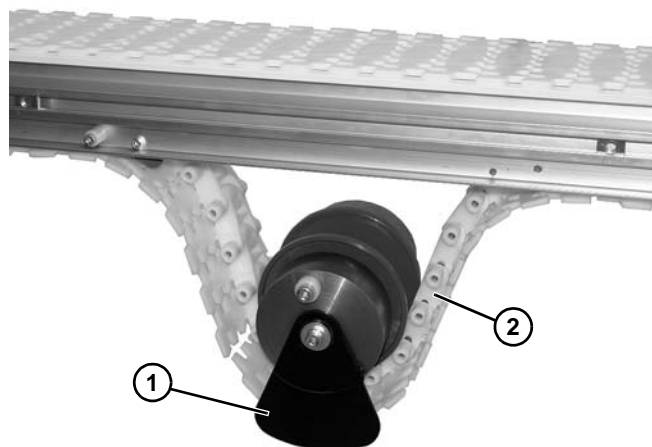
**Figure 59**

## Weighted Take-Up

### NOTE

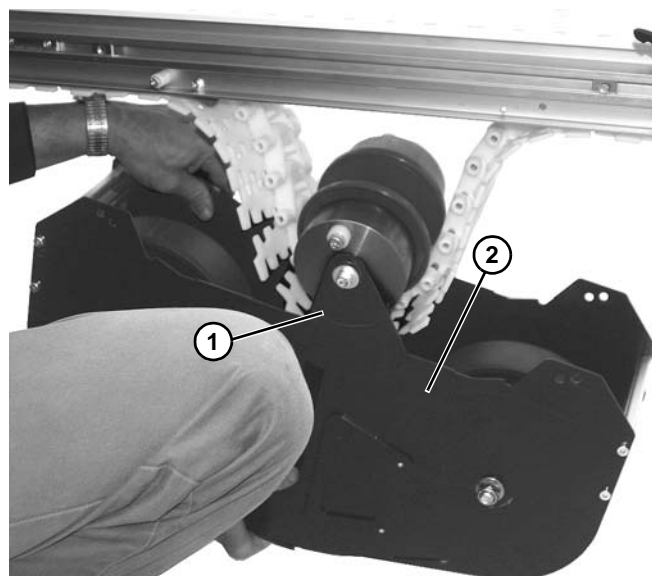
*Remove as much chain slack as possible that will still allow idler to be installed.*

1. Install idler pulley assembly (**Figure 60, item 1**) onto belt (**Figure 60, item 2**).



**Figure 60**

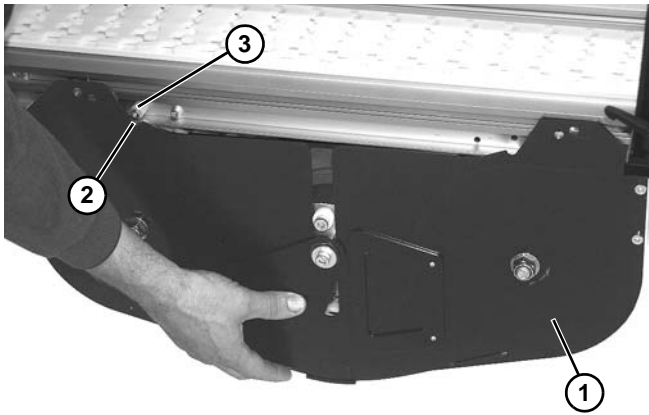
2. Make sure teeth on pulley and guard are facing mating teeth on take up box assembly.
3. Raise weighted take up box assembly, with plate (**Figure 61, item 1**) on idler pulley assembly on outside of outer plate (**Figure 61, item 2**) of weighted take up assembly.



**Figure 61**

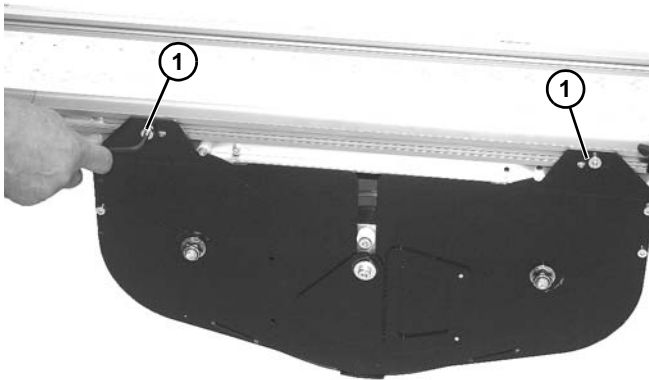
# Installation

4. Raise weighted take up assembly (**Figure 62, item 1**) with notch (**Figure 62, item 2**) in assembly mating with stud (**Figure 62, item 3**) on conveyor frame.



**Figure 62**

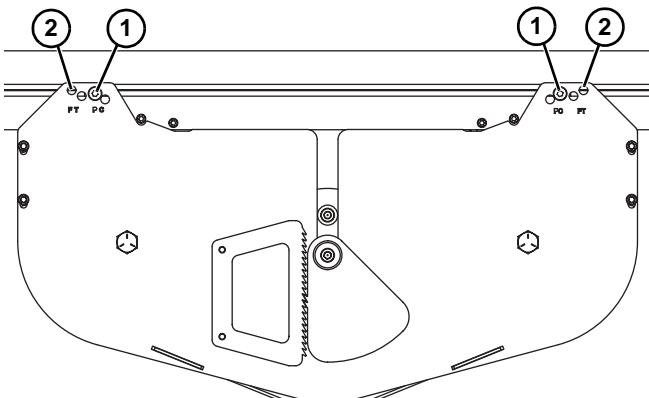
5. Install and tighten two screws (**Figure 63, item 1**) on each side to secure assembly to frame.



**Figure 63**

## NOTE

- For standard belt use these holes (**Figure 64, item 1**).
- For friction insert belt use these holes (**Figure 64, item 2**).



**Figure 64**

## Install Guiding

All guiding must be located and installed by the end user.

## Length Adjustment of the Conveyor Chain

### End Drive Units and Catenary Drive Units

1. The conveyor chain is carried out at the drive end of the conveyor.
2. The transmission guard cover must be removed from the drive unit and the slip clutch disengaged or transmission chain removed. The conveyor chain should now be free to travel within the conveyor beam profile.
3. Catenary protection plates should also be removed to allow easy access for the conveyor chain pin insertion tool.
4. The conveyor chain should be tensioned within the conveyor system by pulling down the conveyor chain at the chain catenary on the underside of the drive unit. Clamp across the conveyor chain to trap the chain on to the beam profile. The clamp should be placed over the edges of the drive unit to reduce the risk of damage to the aluminum profile.
5. Remove all slack links from the conveyor chain using the pin insertion tool.
6. Rejoin the conveyor chain using a new steel pin and plastic pivot.
7. Remove the chain clamp and replace the catenary protection plate and transmission chain. The slip clutch should also be reset.
8. Replace the transmission guard cover. The conveyor is now ready for operation.

### Intermediate Drive Units and Horizontal Bend Drive Unit

1. Conveyors which have no conveyor chain slack should be assembled with a special section of conveyor beam (FVCC), which allows for the chain to be easily inserted and adjusted for tension. (See “Chain Assembly at Chain Disconnecting Module FVCC” on page 20.)
2. Remove the lower part of this conveyor beam section by releasing the four screws.
3. Lift the chain from this section of the beam and clamp the conveyor chain as described above. Adjust the chain tension as for end and catenary drive units.

## Guide Rail System Installation

Guide rails are used to guide products being conveyed, but also to prevent them from falling off the conveyor. Guide rails are supported by guide rail brackets attached to the sides of the conveyor beam. Follow the mounting instructions for the type of bracket used in your application.

Brackets should be placed approximately 500 to 1000 mm apart depending on type of product and if accumulation occurs or not. If brackets are spaced at greater distances than 1000 mm, there is a possibility that guide rails will become deformed due to excessive force.

## High Side Guiding

1. Install stud (Figure 65, item 1) onto retaining clip (Figure 65, item 2) with nut (Figure 65, item 3).

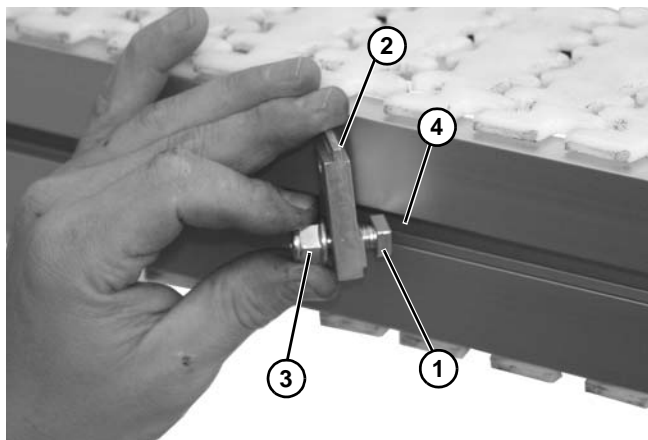


Figure 65

2. Install stud (Figure 65, item 1) into side rail channel (Figure 65, item 4). The end clips should be no greater than 12" from end of the conveyor.

3. Fasten retaining clip (Figure 66, item 1) to conveyor with nut (Figure 66, item 2) on stud.

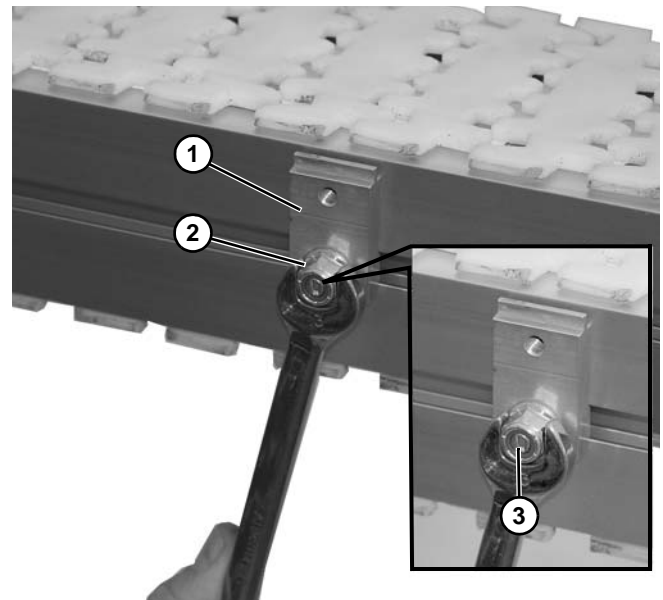


Figure 66

### NOTE

*Be certain that slot (Figure 66, item 3) is close to vertical when finished tightening nut.*

4. Tighten nuts (Figure 66, item 2).
5. Install guide (Figure 67, item 1) and retaining clip (Figure 67, item 2) to conveyor side rail with socket head screw (Figure 67, item 3).

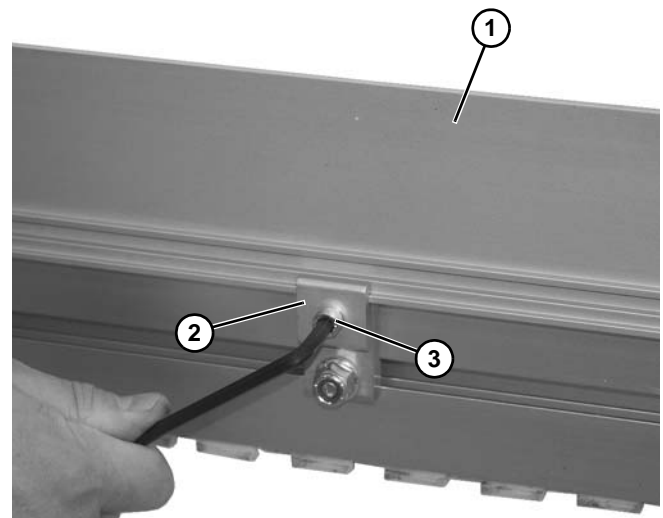
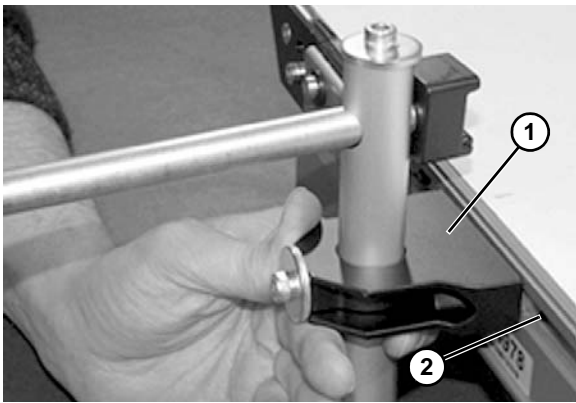


Figure 67

# Installation

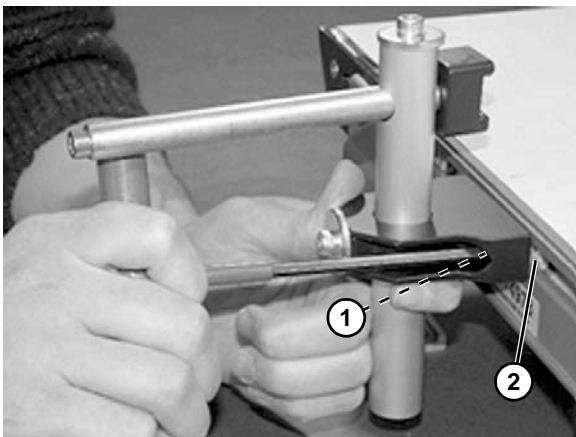
## Heavy Duty Fully Adjustable Guiding

1. Install guide bracket assembly (**Figure 68, item 1**) into the conveyor T-slot (**Figure 68, item 2**).



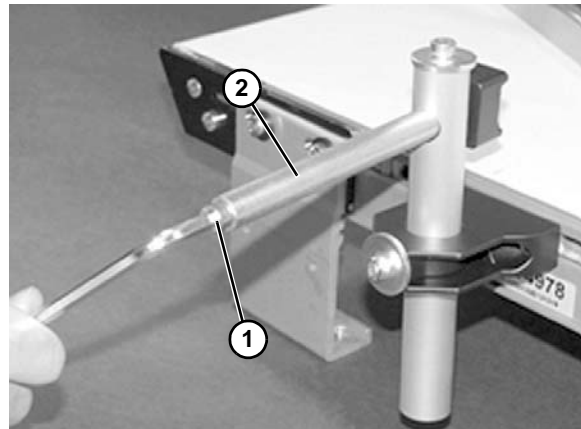
**Figure 68**

2. Tighten screws (**Figure 69, item 1**) making sure T-nut (**Figure 69, item 2**) rotates and engages inside of the T-slot.

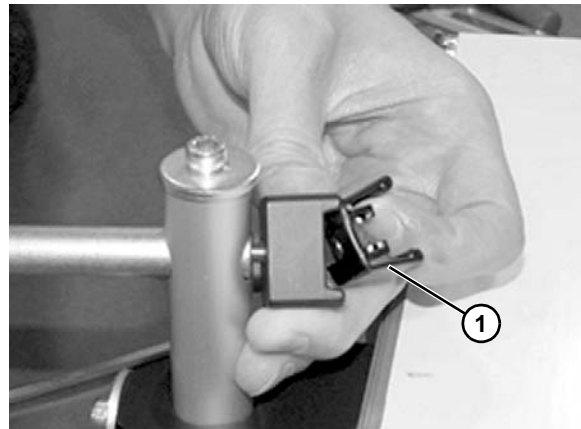


**Figure 69**

3. Loosen screw (**Figure 70, item 1**) on end of shaft (**Figure 70, item 2**) to remove clip (**Figure 71, item 1**).

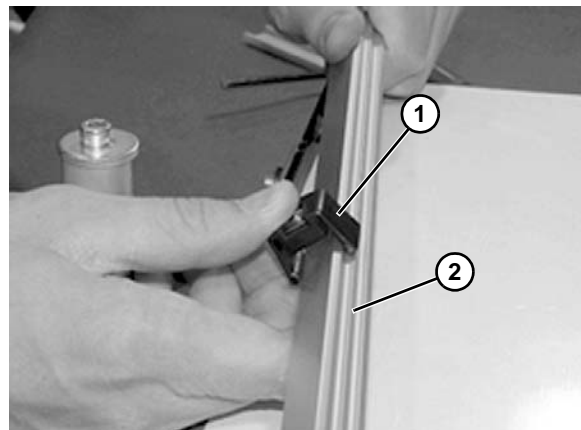


**Figure 70**



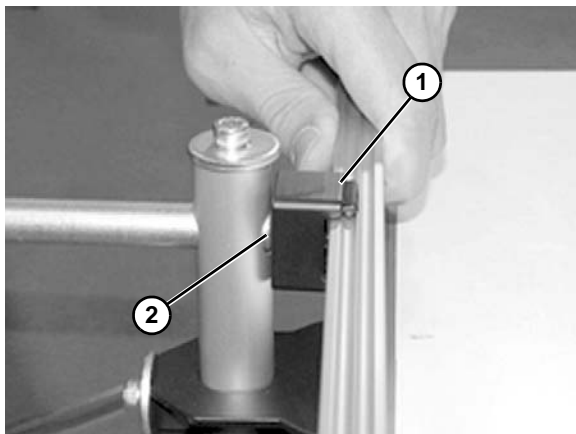
**Figure 71**

4. Snap clip (**Figure 72, item 1**) onto guide rail (**Figure 72, item 2**).



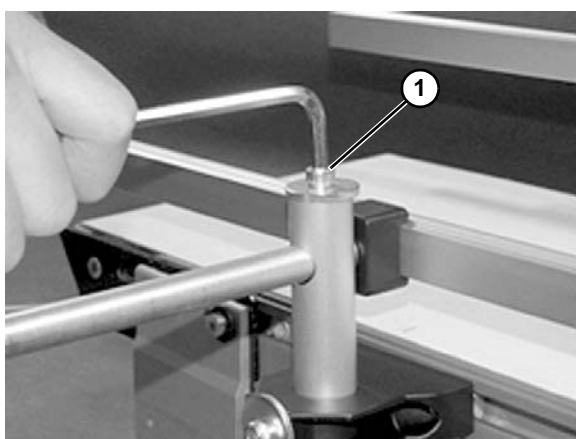
**Figure 72**

5. Reassemble clip (**Figure 73, item 1**) and attach to shaft (**Figure 73, item 2**). Tighten screw (**Figure 70, item 1**) on end of shaft.



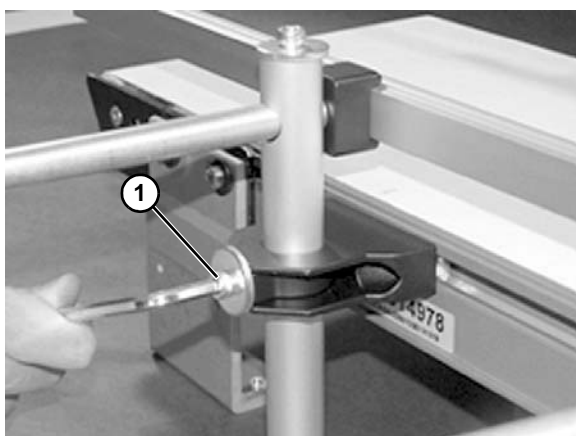
**Figure 73**

6. Adjust rail width with top screw (**Figure 74, item 1**).



**Figure 74**

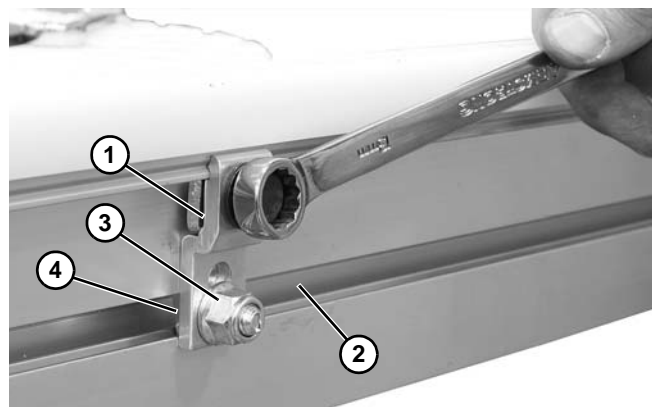
7. Adjust rail height with lower screw (**Figure 75, item 1**).



**Figure 75**

## Puck/Pallet Guiding

1. Install clip assembly (**Figure 76, item 1**) into side rail channel (**Figure 76, item 2**). The end clips should be no greater than 12" from the end of the conveyor.



**Figure 76**

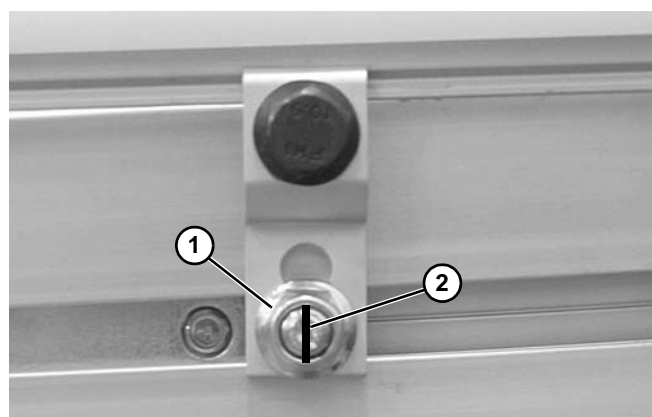
### NOTE

*Make sure that the studs (**Figure 76, item 4**) rotate inside the channel and engage with the conveyor.*

2. Fasten clip (**Figure 76, item 1**) to conveyor with nut (**Figure 76, item 3**) on stud.
3. Tighten nuts (**Figure 77, item 1**).

### NOTE

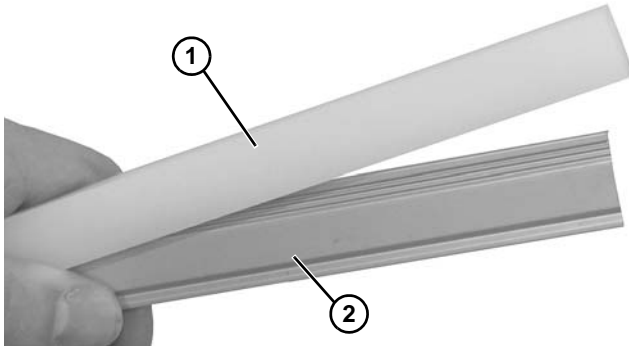
*Be certain that slot (**Figure 77, item 2**) is close to vertical when finished tightening nut.*



**Figure 77**

# Installation

- Attach slide rail (**Figure 78, item 1**) to guiding (**Figure 78, item 2**).

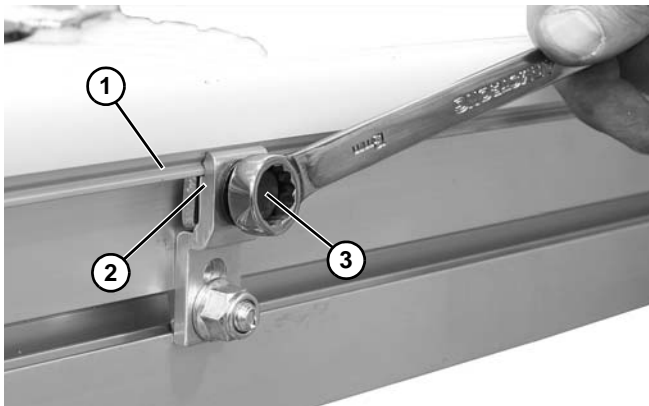


**Figure 78**

## NOTE

*If guide length is less than 250 mm (10"), pin plastic guide to rail using slide rail screw and cutting flush.*

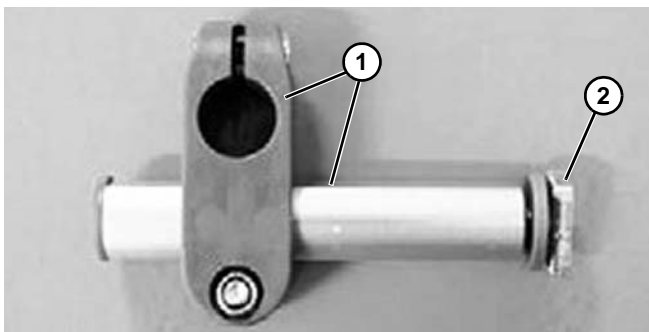
- Attach guiding (**Figure 79, item 1**) to clip (**Figure 79, item 2**) and tighten screw (**Figure 79, item 3**).



**Figure 79**

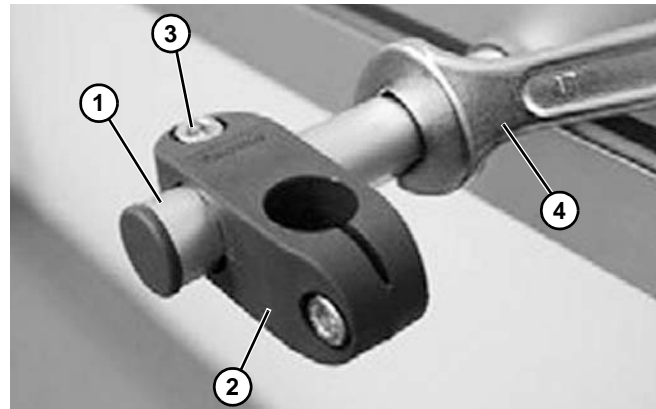
## Adjustable Guide Rail Bracket

- Fasten an adjustable guide rail bracket support (**Figure 80, item 1**) to the conveyor beam using T-bolt (**Figure 80, item 2**).



**Figure 80**

- Attach the guide rail (**Figure 81, item 1**) to the clamp (**Figure 81, item 2**). Tighten the screw (**Figure 81, item 3**). Remember, do not over tighten the screw.



**Figure 81**

- Use a wrench (**Figure 81, item 4**) to tighten the guide rail to the frame. Remember, do not over tighten the screw. Install remaining brackets.

## Assembly with Different Guide Rail Support

### Option 1



**Figure 82**

### Option 2



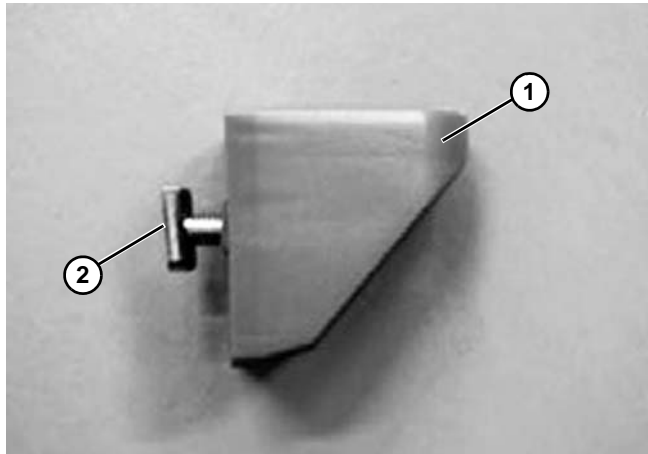
**Figure 83**

## NOTE

*Tighten the screws when the position is justified.*

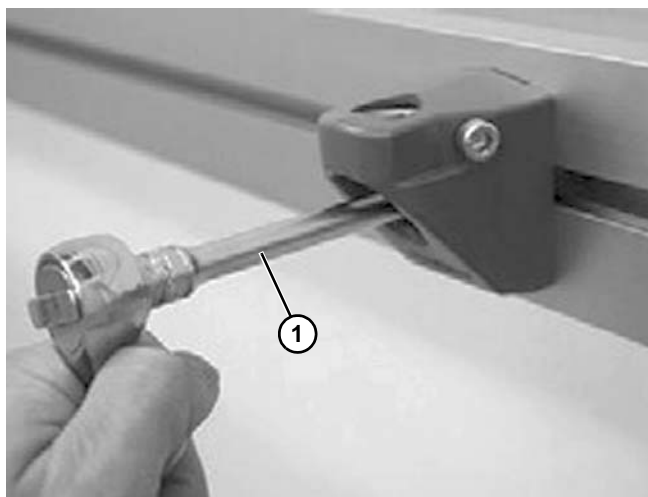
## FGRF- 42x18V Guide Rail Bracket Assembly

1. Prepare the heavy-duty guide rail bracket (**Figure 84, item 1**) with T-bolt (**Figure 84, item 2**).



**Figure 84**

2. Attach the bracket onto conveyor beam and tighten with a socket wrench (**Figure 85, item 1**).



**Figure 85**

## Assembly with Different Guide Rail Support

Option 1



**Figure 86**

Option 2



**Figure 87**

Option 3



**Figure 88**

# Installation

## FGRF- 42x18V Spacer Assembly

1. Attach the spacer (Figure 89, item 1) onto FGRF- 42x18V (Figure 89, item 2) and install correct length T-bolt (Figure 89, item 3).

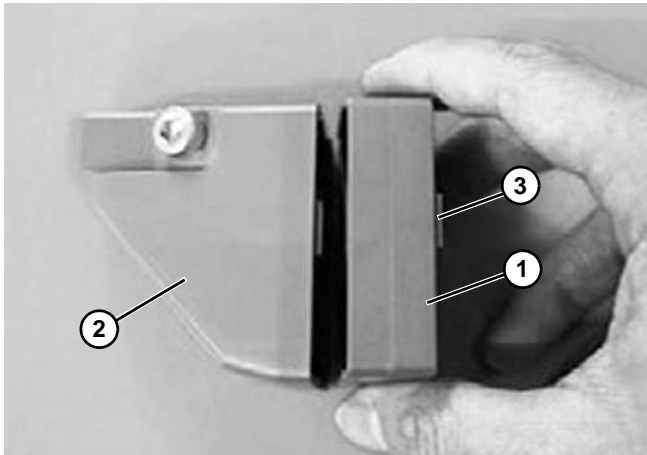


Figure 89

2. Attach the bracket onto conveyor beam and tighten with a socket wrench (Figure 90, item 1).

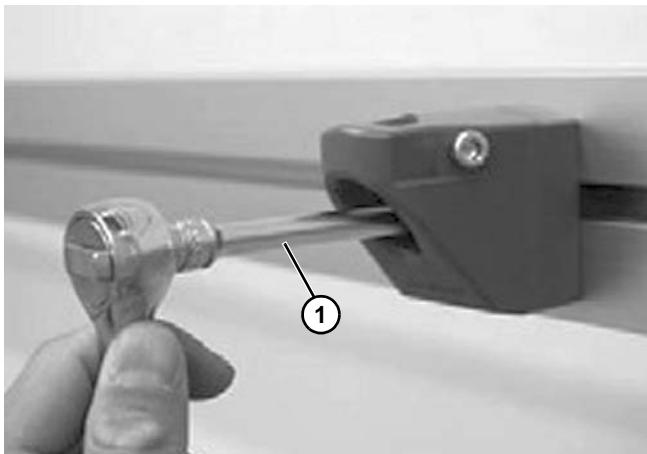


Figure 90

## FGRB- 40x18, FGRB- 40x20 and FGRB- 40x15x20 Guide Rail Bracket Assembly

### Method 1

1. Open the upper and lower caps (Figure 91, item 1) on FGRB - 40 guide rail bracket (Figure 91, item 2), and install T-bolt.

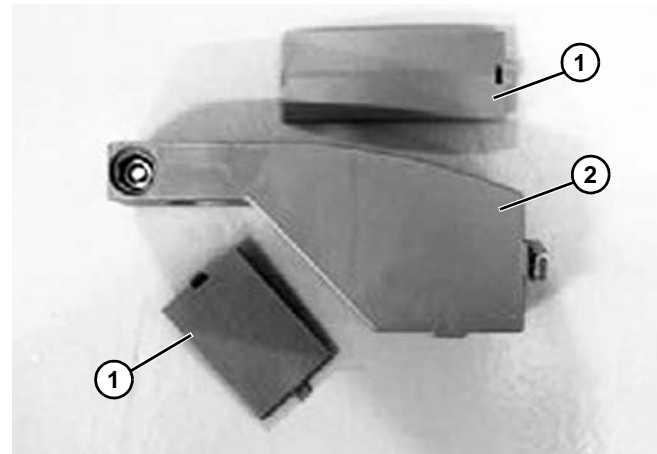


Figure 91

2. Attach the bracket onto conveyor beam and tighten with a socket wrench (Figure 92, item 1). Install upper and lower caps.

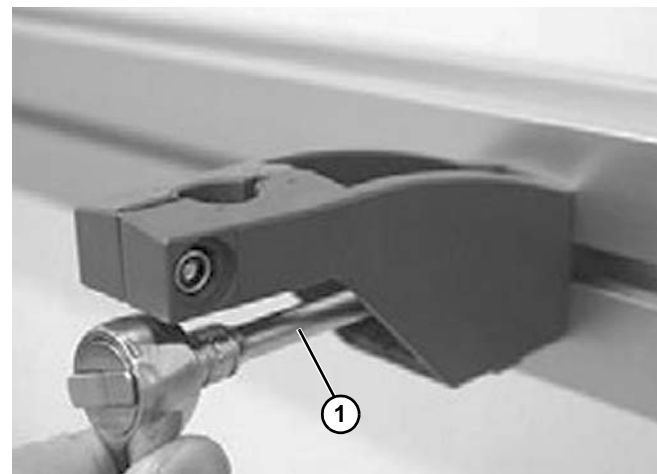
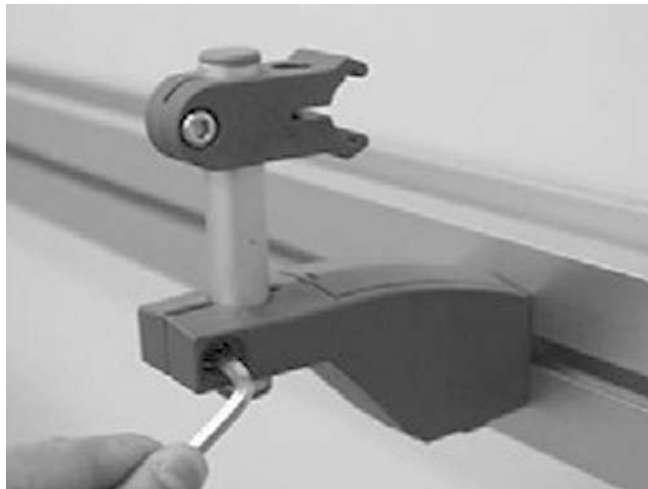


Figure 92

## Assembly with Different Guide Rail Support

### Option 1



**Figure 93**

### Option 2



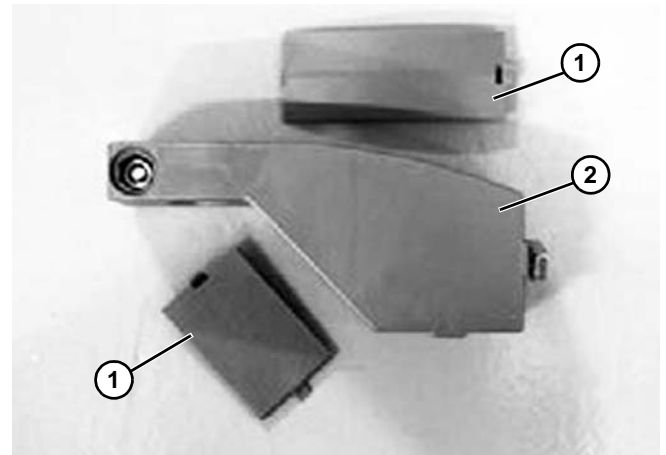
**Figure 94**

### NOTE

*Tighten all the screws when the position is justified. Remember to assemble the upper and lower caps onto the bracket.*

## Method 2

1. Open the upper and lower caps (**Figure 95, item 1**) and prepare the FGRB - 40 guide rail bracket (**Figure 95, item 2**) with T-bolt.



**Figure 95**

2. Attach the bracket onto conveyor beam and tighten with a socket wrench. Install both caps of the bracket.

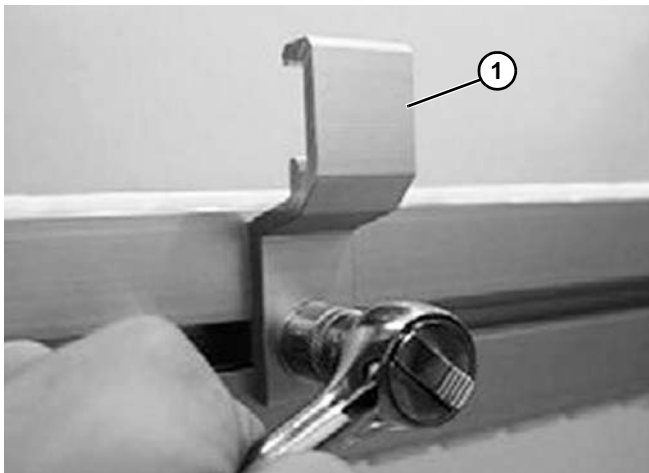


**Figure 96**

# Installation

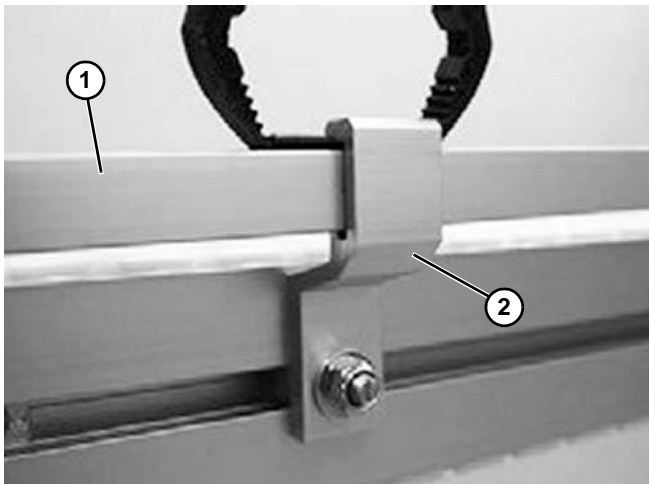
## Fixed Guide Rail Bracket Installation

1. Fasten a fixed guide rail bracket support (**Figure 97, item 1**) to the conveyor beam using T-bolt.



**Figure 97**

2. Attach the guide rail (**Figure 98, item 1**) to the bracket (**Figure 98, item 2**). Clamp the spring pin into the slot between bracket and guide rail to the fixed position.



**Figure 98**

## Guide Rail Connecting Installation

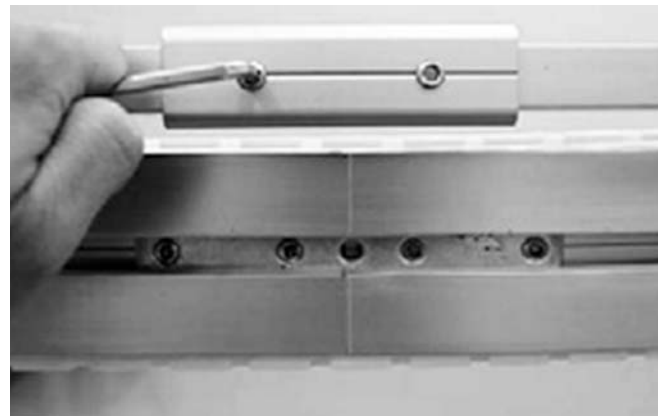
### Rail Connecting

1. Slide the guide rail sleeve (**Figure 99, item 1**) into either one of the guide rail profile that you are going to join.



**Figure 99**

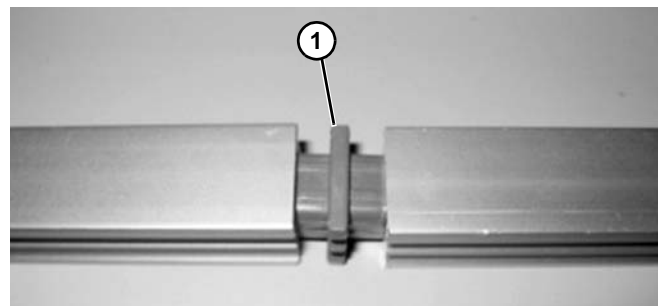
2. Move the guide rail sleeve into second profile. Tighten set screws.



**Figure 100**

### Connecting Plug

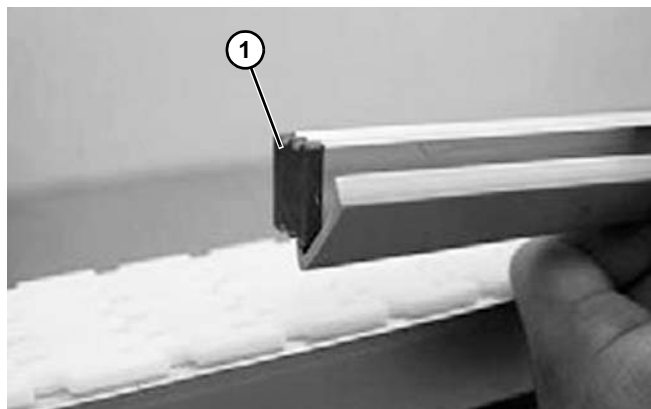
1. Connecting plugs (**Figure 101, item 1**) are pressed into two guide rail ends with soft hammer.



**Figure 101**

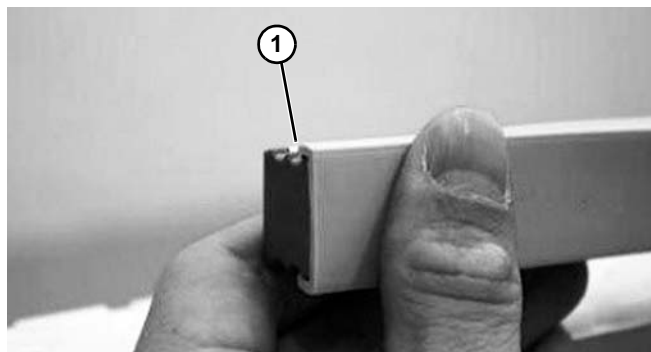
## Guide Rail Cover Installation

1. To prevent products from being scratched, a plastic guide rail cover (**Figure 102, item 1**) can be snapped on to the inside of the guide rail.



**Figure 102**

2. Make sure that all cover joints (**Figure 103, item 1**) are smooth, so that products do not get caught or damaged. Covers are not required on guide rail joints.



**Figure 103**

## Final Preparations

### Plug Beam Ends

Ensure that end caps have been fitted to all aluminium profile ends. The beam profiles should be deburred before fixing end caps. It may be necessary to fix the cap into position using a soft-faced hammer.

### Anchor Feet to the Floor

After the assembly of all components, it is recommended to anchor the conveyor support feet to the floor. Use a type of fastener that is right for the kind of floor where the conveyor is installed.

Instability of the conveyor during operation may result in a dangerous operating environment or damage the conveyor components.

## Other Preparations

- Adjust the height of the structural beam if necessary.
- Make sure that the installation is stable and that all screws have been properly tightened.
- Make sure that all electrical equipment and power supply are properly connected.
- Make sure that the conveyor is running in the correct direction before starting the conveyor!
- Tighten the slip clutch to a suitable friction.
- Make sure that all chain and belt covers are attached correctly.
- In pallet installations, make sure that all pneumatic equipment is properly connected.

### NOTE

*Remember that conveyor chains should always be pulled, not pushed, by the drive unit.*

## Start-Up and Testing

### Safety Considerations

To eliminate the risk of accidents, it is important to be aware of certain areas of the conveyor where special caution is required, during installation, operation, and maintenance. Some areas present a higher danger to personal safety, and various kinds of safety devices need to be installed.

- All pinch and shear points as well as other exposed moving parts that present a hazard to employees at their workstations or their passageways must be safeguarded.
- Cleated conveyor chains are more susceptible of creating pinch and shear points than plain chain.
- When two or more pieces of equipment are interfaced, special attention must be given to the interfaced area to ensure proper safeguarding.
- For overhead equipment, guards must be provided if products may fall off the equipment for some reason. The same applies to all incline, decline, and vertical conveyors.

# Installation

## Safeguarding can be achieved by:

- Location – locate the hazardous area out of reach of the personnel involved.
- Guards – mechanical barriers preventing entry into the hazardous area or protecting against falling goods.
- Control devices – machine controls preventing or interrupting hazardous conditions.
- Warnings – instructions, warning labels, or sound or light signals, alerting on hazardous conditions.
- Warnings shall be used when other means of safeguarding will impair the function of the installation.

### **⚠ WARNING**

**It must be difficult to bypass or inactivate safeguards during operation! Safety devices should be designed to minimize discomfort or difficulties for operators.**

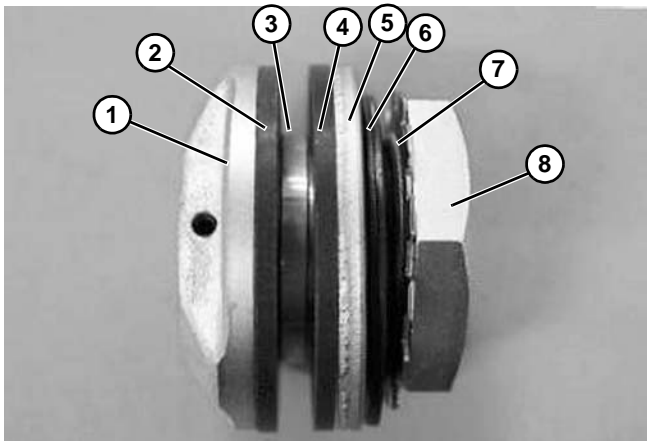
## Torque Limiter Adjustment for Suspended Drive Units

### Introduction

The slip clutch on the drive unit is a safety device which allows the chain to stop if the load becomes excessive. It has two purposes:

- Prevent damage to conveyor
- Prevent damage to the products on the conveyor (See **Figure 104**.)

### Name of Parts



**Figure 104**

- |   |                 |
|---|-----------------|
| 1 | Hub             |
| 2 | Friction Facing |
| 3 | Bushing         |
| 4 | Pressure Plate  |
| 5 | Disk Spring     |
| 6 | Lock Washer     |
| 7 | Pilot Plate     |
| 8 | Adjustable Bolt |

## Torque Setting

### **NOTE**

*It may be easier to adjust torque limiter off of conveyor to adequately secure inner race with shaft locked in a vise while turning adjusting nut.*

Tighten adjusting nut hand tight (approximately ¼ turn after first making contact). Mark nut flat closest to keyway. Continue to tighten to specified rotation to achieve desired torque: Note - For maximum drive torque use solid sprocket with no overload catenary protection.

Rotation Angle	Slip Torque	Chain Pull
60 Degrees	21 Nm	328 N
120 Degrees	35 Nm	547 N
180 Degrees	46 Nm	719 N
240 Degrees	54 Nm	844 N
Solid Sprocket	-	1250 N

Once adjusted nut is tightened to desired rotation, bend locking tabs down against nut flats in at least 2 locations.

## Replace the Friction Facing

Change the friction facing when they reach roughly half the thickness of 1.6 mm (0.063 in.). Before replacing the friction facing, each part must be completely free of oil, rust and dirt.

## Maintenance and Precautions after the Replacement Procedure

Replace the friction facing and bushing if they wear.

Keep the torque limiter free from water and oil. If torque limiter slips, re-adjust as necessary.

## Safety

### **⚠ WARNING**

- Before carrying out maintenance, make sure there is no load or turning force applied to the machine.
- Inspect operation periodically for overloads.

### **⚠ CAUTION**

- Mechanical parts may wear depending on the rotation speed and slipping time. Check the operation periodically.

---

# Preventive Maintenance and Adjustment

---

## Start-Up and Maintenance Schedule

The chains are made of acetyl resin, which has an excellent combination of strength, wear, chemical resistance, impact strength and temperature range. Chain failures like breakage, pin bending, and high wear might occur if the actual pull is higher than the permissible chain limit. There is also high risk of slip-stick effect if the conveyor is running at high chain tension.

It is important for the chain to run in the correct direction. The chain is marked with direction of travel by an arrow on the side of the chain. Over tensioning the chain can cause chain failure. Signs of over tensioning and overloading are broken links or bent link pins. On catenary drive units it is important that there is visible chain slack on the bottom of the drive units when running.

## Chain Lubrication

Lubrication of the chain where it meets the slide rails and inside by the pin and pivot location can reduce friction - allowing the chain to run more smoothly, quietly, and last longer. Spray silicon with Teflon™ is the recommended lubrication, and can be applied at the drive tail to the inside of the chain through the slot in the catenary drive tails or gravity take-up units.

## Wear

The degree of wear on a conveyor depends on a number of factors, such as:

- Running time
- Load, contact pressure
- Speed
- Product accumulation
- Sharp or rough products
- Chemicals
- Foreign particles, e.g. chips, grinding particles, broken glass, sand, sugar
- Temperature
- Plain bends

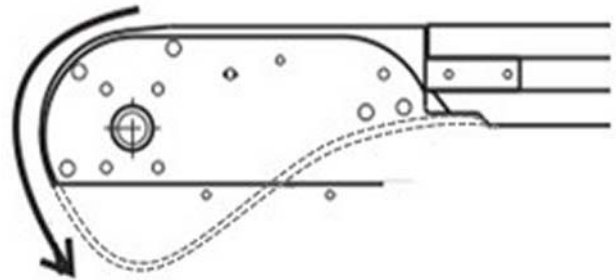
Try to minimize the running time for the conveyor by stopping it when there is no transport. Multiple horizontal and vertical plain bends in a conveyor will often result in increased wear.

## Chain Elongation

Acetyl resin is an elastic material. In addition to the elastic elongation, the chain will exhibit elongation because of material creeping. The magnitude of chain elongation will depend on the chain tension. Unless a weighted take-up is used, the chain elongation will show up at the bottom of the drive unit. Too much of the chain slack may cause high wear at the drive unit entry point. Chain slack of up to 150 mm (5.9 in.) is acceptable during normal running but any slack longer than that is not advisable. The chain slack might also hit on any part below it. For this case, the chain slack should be shortened much earlier. In a normal case, chain should be shortened after run-in time of 40 hours. The next inspection should be made after 200 hours of running and then every 1600 hours. More frequent inspections are recommended if the conveyor is long and has high load.

The chain should never be so tight that there is no slack during the operation. If there is too much slack, there will be excessive wear on the chain guides and the chain. This could be a risk for injury. If the slack on the conveyor chain is unacceptably high, it must be shortened by splitting the chain and removing the necessary number of links.

- The conveyor chain must show some slack during operation (See **Figure 105**).



**Figure 105**

- The conveyor chain does not need to show any slack when the conveyor chain is stationary or when a weighted take-up is used.

# Preventive Maintenance and Adjustment

## Inspection

Visually check the slide rail in horizontal and vertical bends after every 200 hours of operation. The chain can stay in place during the inspection. Replace any worn out slide rail. Remove the chain from the conveyor and inspect the slide rail carefully once every 1500 hours of operation. Check for any worn out slide rail and any other unusual conditions and make necessary replacement. Clean up any dirt accumulation in the conveyor beam, especially before any plain bends, drive unit, and idler end.

## Drive Unit

The drive unit can be equipped with different brands. Please follow the maintenance recommendations from the manufacturer.

## Maintenance Schedule

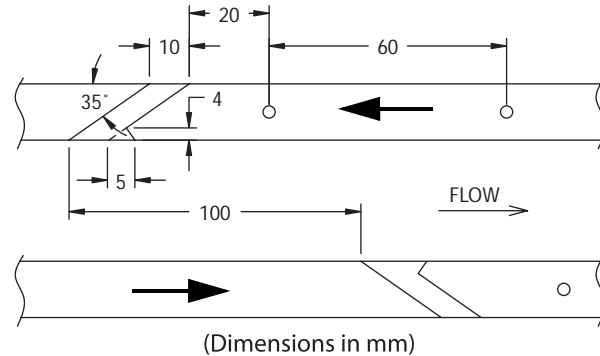
Maintenance is recommended to be carried out every 3rd, 6th and 12th month, and subsequently every 6th month, considering the running condition. Following are the recommended actions to be carried out:

### First 3rd Month, 6th Month, and Every 6th Month Following

- Shorten the chain, if required.
- Visually inspect the condition of the slide rail, sprocket, wheel, and chain guides.
- Check any high wear part on the conveyor, and replace when necessary.
- Clean up any foreign accumulation that might block the smooth flow of the conveyor.
- Check the gearbox oil level and top off when necessary.
- Check all support structures, slide guides, and conveyor joints for looseness. Replace when necessary.

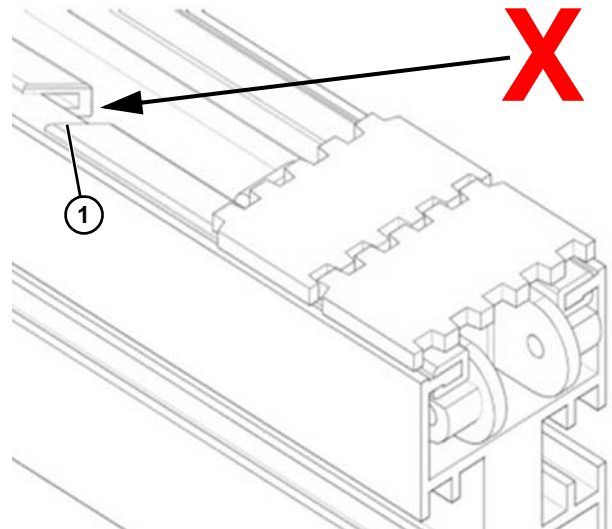
## Checking Slide Rail with the Conveyor Chain in Place

The slide rail needs to be checked after every 200 hours of operation. Check on a stationary state with the chain in place. **Figure 106** shows the correct configuration of joints.



**Figure 106**

- Check the screwing points on the slide rail.
- Check the joints section on the slide rail.
- Check that the gap (**Figure 107, item 1**) between the slide rails and that the joints fit correctly.



**Figure 107**

- Check that the nylon screw is in place and does not protrude over the surface of the slide rail.
- Check that the joint sections are not deformed.

---

# Preventive Maintenance and Adjustment

---

## Checks When the Chain is Removed

The slide rail needs to be checked once a year or after 1500 hours of operation. The chain should be removed from the conveyor beam for checking the slide rail. Check carefully on the condition of wear and the screws.

## Horizontal Bends

Horizontal bends need to be checked carefully after every 200 hours of operation.

Check the inner slide rail in horizontal bends carefully, since the friction here is particularly high. The conveyor chain develops more pressure on the inner slide rail compared to the outer slide rail.

- Check the slide rail for scratches and notches.
- Replace the slide rail and the screws, if necessary.
- Clean the conveyor chain and check the condition of the chains.
- Clean the conveyor beam.

## Safety Devices

Safety devices should be checked at regular intervals.

- Check the motor cover for the suspended drive (See **Figure 108**).



**Figure 108**

- This motor cover must always be in place when the conveyor is operating.
- The drive unit should always have a chain cover to protect the safety of the users. The chain slack can be seen when the conveyor is running at the drive unit. Check that the chain cover plates are in place, and that the chain does not slacken enough to hang below the plates (**Figure 109**).



**Figure 109**

- Check that the chain cover is in place for the conveyor chain on the intermediate drive units and the catenary drive units.

# Preventive Maintenance and Adjustment

## Troubleshooting

Symptom	Cause	Corrective Action
Jerky running	<ul style="list-style-type: none"> <li>• Damage or badly fitted slide rail.</li> <li>• Incorrectly adjusted slip clutch.</li> <li>• Worn transmission parts.</li> <li>• Conveyor chain is too tight or loose.</li> <li>• Dirty conveyor.</li> </ul>	<ul style="list-style-type: none"> <li>• Inspect and replace as necessary.</li> <li>• Adjust slip clutch.</li> <li>• Check/replace transmission chain, chain drive sprocket.</li> <li>• Lubricate chain with silicone spray with Teflon™.</li> <li>• Tension conveyor chain correctly.</li> <li>• Clean conveyor chain/slide rail.</li> <li>• Add weighted take-up.</li> </ul>
Drive unit is running; conveyor chain is not running	<ul style="list-style-type: none"> <li>• Incorrectly adjusted slip clutch.</li> <li>• Friction discs in slip clutch are worn or contaminated.</li> <li>• Damage/badly fitted slide rail.</li> <li>• Transmission products are not fitted.</li> </ul>	<ul style="list-style-type: none"> <li>• Check adjustment of slip clutch.</li> <li>• Check and replace if necessary.</li> <li>• Check the free running of the conveyor chain.</li> <li>• Check and fit.</li> </ul>
Motor overheating on drive unit	<ul style="list-style-type: none"> <li>• Overloaded conveyor.</li> <li>• Gearbox leaking oil.</li> <li>• Dirty conveyor.</li> </ul>	<ul style="list-style-type: none"> <li>• Remove products from conveyor and test run.</li> <li>• Check actual conveyor load against recommended loading. If possible, add breaks to add more drives.</li> <li>• Check output shaft seal and area around motor/gearbox interface.</li> <li>• Clean the conveyor chain with warm water.</li> </ul>
Noise	<ul style="list-style-type: none"> <li>• Worn or damaged bearings in drive unit.</li> <li>• Damage/badly fitted slide rail.</li> <li>• Excessive conveyor speed.</li> <li>• Incorrect conveyor chain tension.</li> </ul>	<ul style="list-style-type: none"> <li>• Check/replace drive unit.</li> <li>• Check the free running of the conveyor chain, especially in slide rail joints.</li> <li>• Check actual load against recommended loading.</li> <li>• Lubricate chain with silicone spray with Teflon™.</li> <li>• Lengthen or shorten conveyor chain.</li> </ul>
Abnormal wear of plastic parts	<ul style="list-style-type: none"> <li>• Overloaded conveyor.</li> <li>• Ambient temperature too high.</li> <li>• Foreign object dropped on the conveyor chain.</li> </ul>	<ul style="list-style-type: none"> <li>• Remove products from conveyor and test run.</li> <li>• Check the free running of the conveyor chain.</li> <li>• Check actual conveyor load against recommended loading. If possible, add breaks the conveyor and add more drives.</li> <li>• Check against recommended temperature for conveyor.</li> <li>• Replace the broken section of chain.</li> </ul>
Clutch Ratcheting or slipping	<ul style="list-style-type: none"> <li>• Excessive or accumulated load.</li> <li>• Improper ratchet clutch tensioning.</li> <li>• Damaged or missing chain assembly parts.</li> <li>• Accumulation of conveyed material or foreign objects inside of casing.</li> </ul>	<ul style="list-style-type: none"> <li>• Avoid load buildup by running conveyor continuously.</li> <li>• Do not manually surge load conveyor.</li> <li>• Refer to ratchet clutch adjustment in Maintenance.</li> <li>• Review belt and repair or replace as required.</li> <li>• Remove chain and clean out.</li> </ul>

# Preventive Maintenance and Adjustment

## Required Tools

- 3/32" hex wrench
- 3 mm hex wrench
- 4 mm hex wrench
- 5 mm hex wrench
- 6 mm hex wrench
- 8 mm hex wrench
- 10 mm wrench
- 13 mm wrench
- 16 mm wrench
- Chain Removal Tool
- Slide Rail Cutter
- Drill Fixtures for Slide Rails
- Riveting Tool

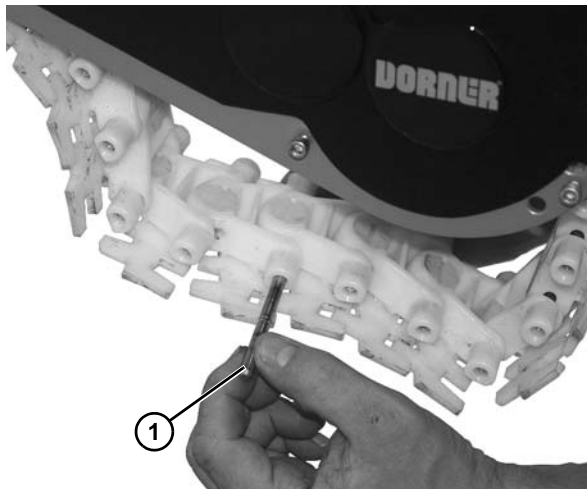
## Conveyor Chain Replacement

<b>⚠ WARNING</b>

<b>SEVERE HAZARD!</b> <b>LOCK OUT POWER</b> before removing guards or performing maintenance. Exposed moving parts can cause serious injury.

## Replacing a Section or Entire Chain

1. Use chain removal tool or a punch and hammer to push the chain rod (**Figure 110, item 1**) out.



**Figure 110**

<b>⚠ WARNING</b>

<b>SEVERE HAZARD!</b> <b>If conveyor chain is damaged or worn, replace chain section.</b>

2. Replace old section of chain.

<b>⚠ CAUTION</b>
<b>DO NOT reuse chain rods that are damaged, bent, or show signs of wear.</b>

<b>NOTE</b>
<i>Drive spindle shaft assembly replacement is recommended with belt replacement (see "Drive Spindle Shaft Replacement" on page 39).</i>

# Preventive Maintenance and Adjustment

## Conveyor Chain Tensioning

### ⚠ WARNING



#### SEVERE HAZARD!

**LOCK OUT POWER** before removing guards or performing maintenance. Exposed moving parts can cause serious injury.

### NOTE

*Belt should not be stretched during installation. A proper length of belt can be installed by interlocking the ends by hand without excess links.*

1. Remove one or more chain links to take up tension. Refer to "Replacing a Section or Entire Chain" on page 37.

### NOTE

*After shortening chain, ensure there is visible slack in chain (while running) at catenary drive tails. If chain is not visible in cover slot (Figure 111, item 1) inspect from end.*

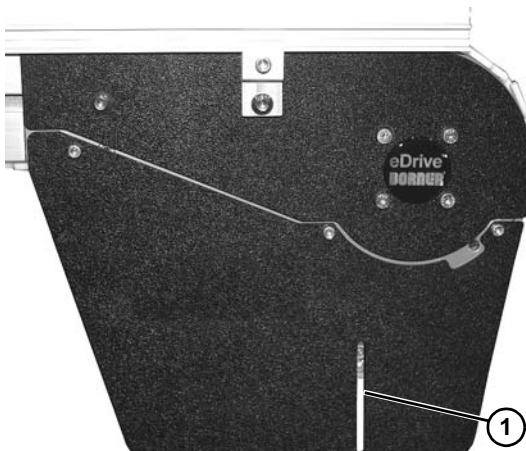


Figure 111

## Slide Rail Replacement

Replace the slide rails if they become worn.

### NOTE

*Top and bottom slide rails are shipped pinned/attached at various places on conveyor.*

1. Remove belt. See "Conveyor Chain Replacement" on page 37.
2. Drill out or push out drilled pinned screws or rivets (Figure 112, item 1).
3. Remove slide rail (Figure 112, item 2) from top of frame assembly.



Figure 112

4. Cut and remove worn slide rail section and replace with new slide rail. See "Installation" section, starting on page 15.
5. Remove lower slide rails, as needed, repeat procedure used for upper slide rails.
6. Install new slide rails. See "Installation" section, starting on page 15.

## Idler Pulley Replacement

### ⚠ WARNING

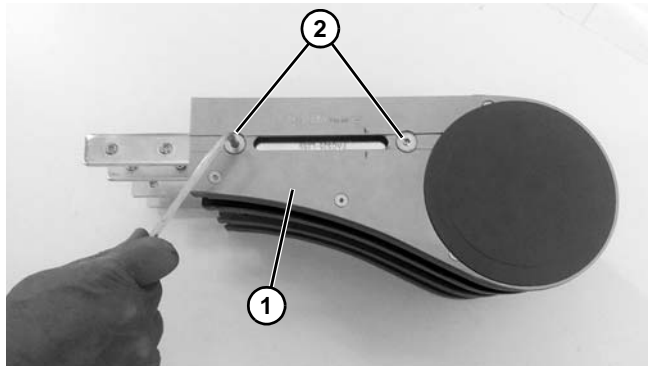


**Exposed moving parts can cause severe injury. LOCK OUT POWER** before removing guards or performing maintenance.

1. Remove chain. See "Conveyor Chain Replacement" on page 37.

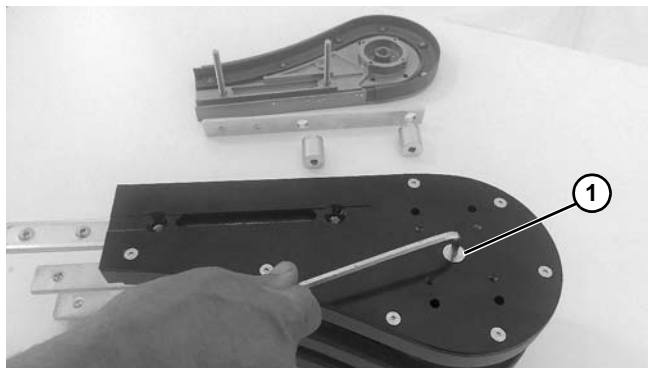
# Preventive Maintenance and Adjustment

2. Remove outer plates (**Figure 113, item 1**) and connecting hardware by removing two screws (**Figure 113, item 2**) on both sides of the conveyor.



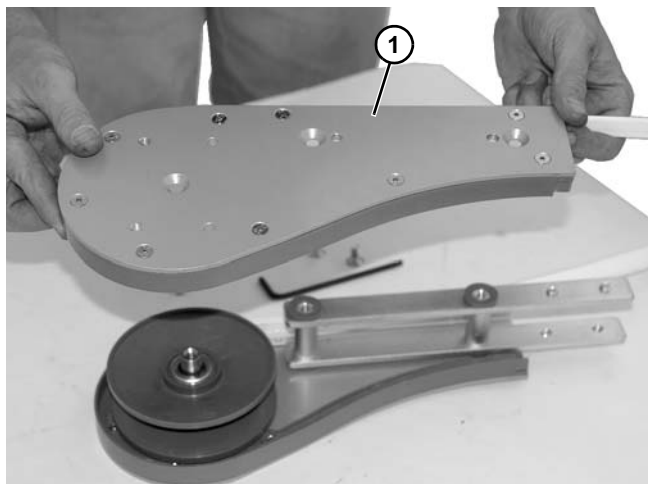
**Figure 113**

3. Remove flat head screw (**Figure 114, item 1**).



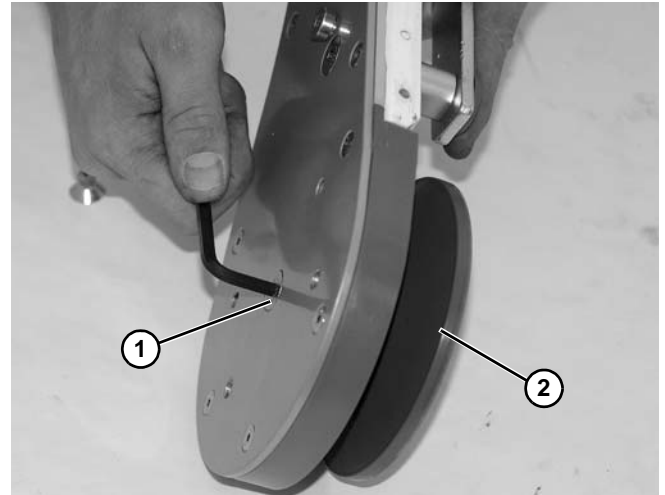
**Figure 114**

4. Remove the head plate (**Figure 115, item 1**) from the idler end.



**Figure 115**

5. Remove flat head screw (**Figure 116, item 1**) and remove idler pulley (**Figure 116, item 2**) from idler head plate assembly.



**Figure 116**

6. Install components reverse of removal.

## Drive Spindle Shaft Replacement

### **⚠ WARNING**

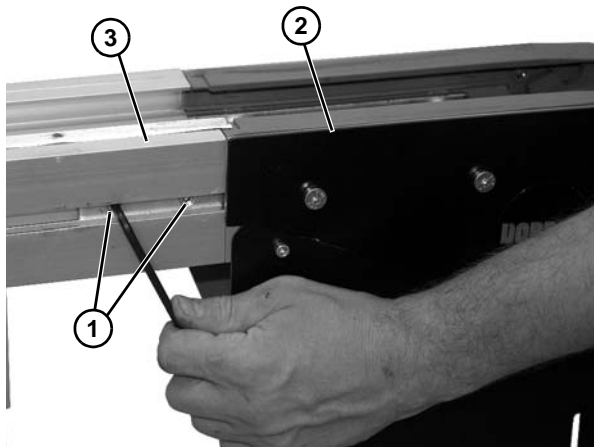


**Exposed moving parts can cause severe injury. LOCK OUT POWER before removing guards or performing maintenance.**

1. Remove chain. See “Conveyor Chain Replacement” on page 37.
2. Remove the gearmotor. See “Gearmotor Drive” on page 43.

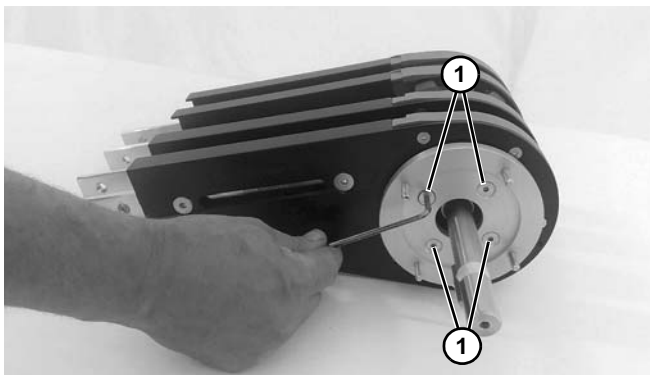
# Preventive Maintenance and Adjustment

3. Loosen two screws (**Figure 117, item 1**) on each side of conveyor, and remove the drive tail assembly (**Figure 117, item 2**) from the conveyor frame (**Figure 117, item 3**).



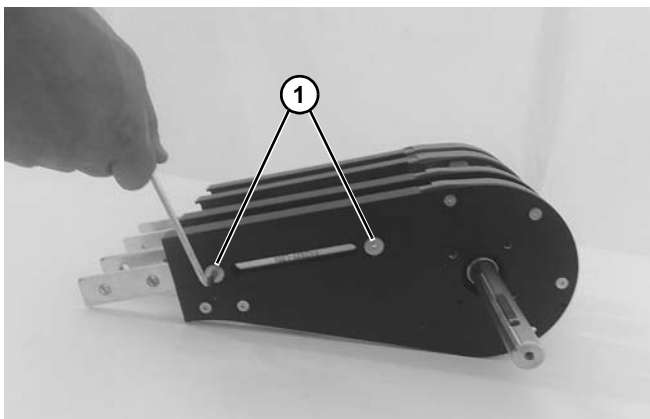
**Figure 117**

4. Remove four screws (**Figure 118, item 1**) on side of drive spindle.



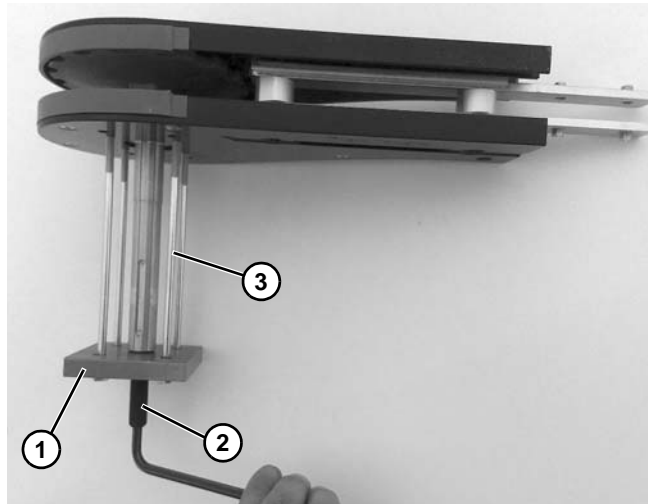
**Figure 118**

5. Remove two screws (**Figure 119, item 1**) on side of drive spindle.

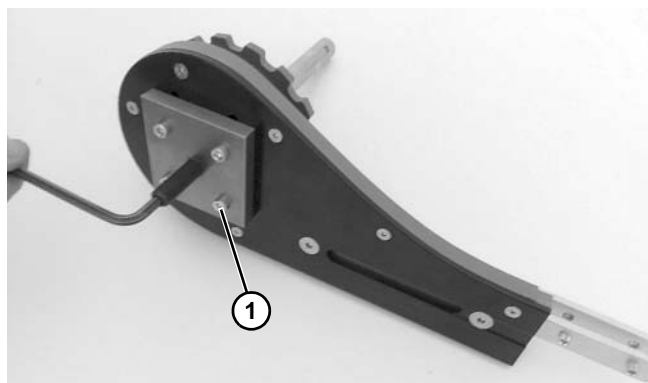


**Figure 119**

6. Use the bearing tool (**Figure 120, item 1**) to unseat bearings by inserting the four screws and turning the threaded rod (**Figure 120, item 2**) to push bearing out. NOTE: Insert the longer screws (**Figure 120, item 3**) on the drive shaft side and the shorter screws (**Figure 121, item 1**) on the non-shaft side.



**Figure 120**



**Figure 121**

# Preventive Maintenance and Adjustment

7. Remove the head plates (Figure 122, item 1) from the drive tail.

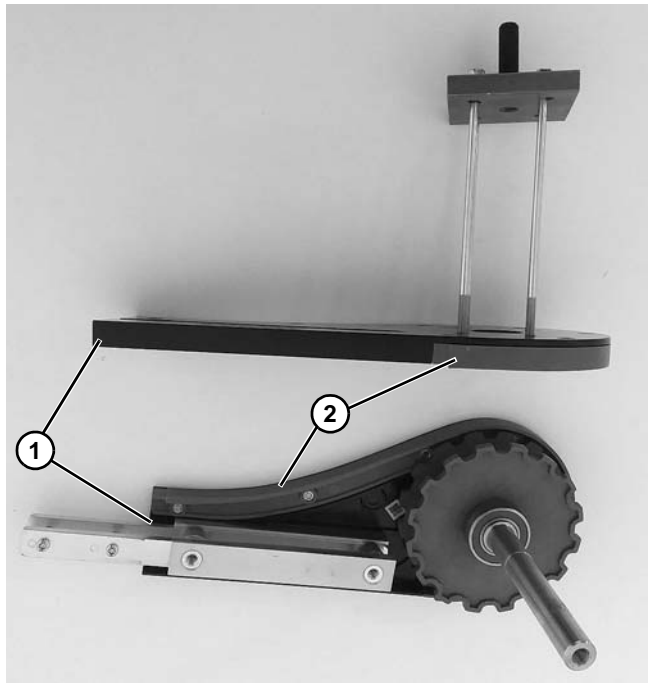


Figure 122

8. Install components reverse of removal.

## Retaining Guide Replacement

### Cantenary Drive End

1. Remove three socket head screws (Figure 123, item 1) and remove drive plate guard (Figure 123, item 2) from drive plate (Figure 123, item 3).

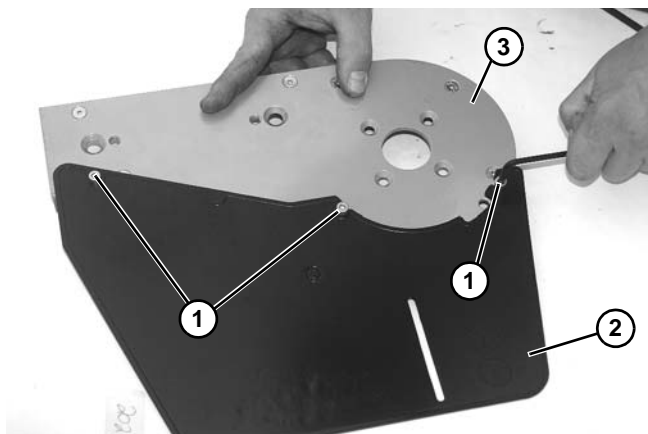


Figure 123

2. Remove two screws (Figure 124, item 1) from outer plates (Figure 124, item 2).

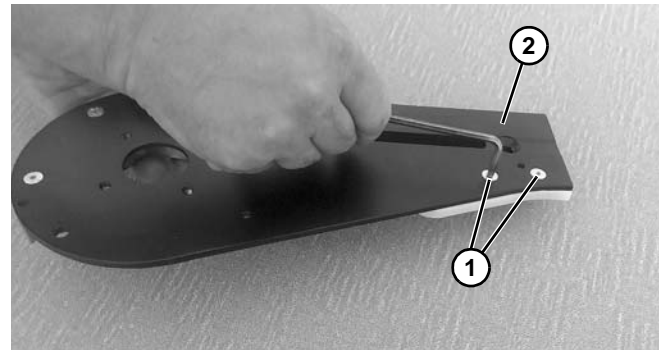


Figure 124

3. Remove drive return guide (Figure 125, item 1).

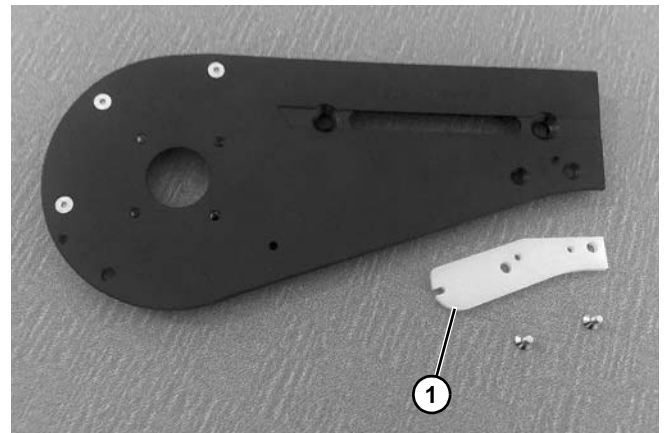


Figure 125

4. Remove two screws (Figure 126, item 1) from inside plates.

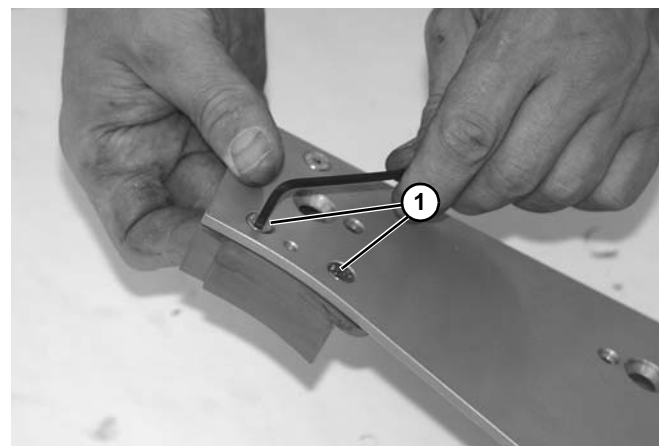
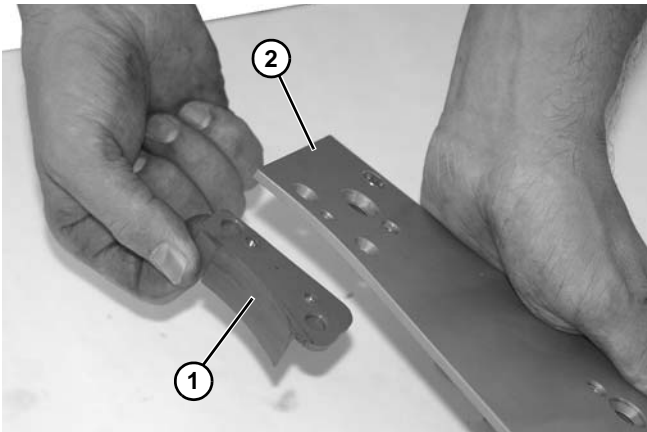


Figure 126

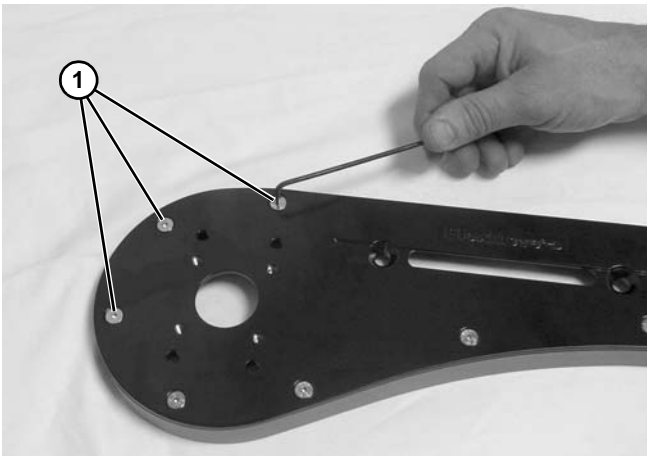
# Preventive Maintenance and Adjustment

5. Remove lower retaining guide (**Figure 127, item 1**) from drive plate (**Figure 127, item 2**).



**Figure 127**

6. Remove three socket head screws (**Figure 128, item 1**).



**Figure 128**

7. Remove upper retaining guide (**Figure 129, item 1**) from drive plate (**Figure 129, item 2**).

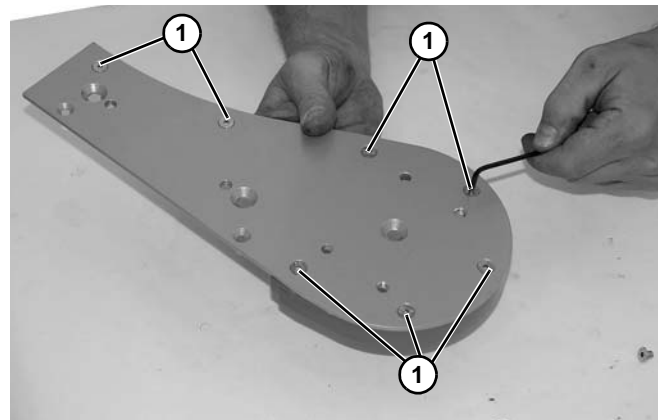


**Figure 129**

8. Install components reverse of removal.

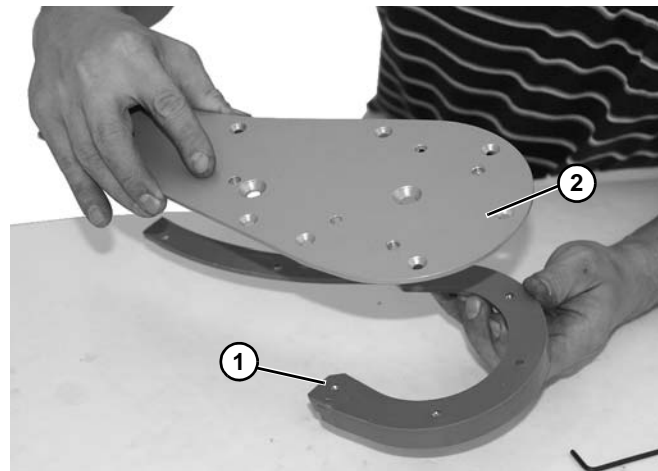
## Idler End and GP Drive Tail

1. Remove seven (7) socket head screws (**Figure 130, item 1**) from idler head plate assembly.



**Figure 130**

2. Remove retaining guide (**Figure 131, item 1**) from idler head plate assembly (**Figure 131, item 2**). Replace components, as needed.



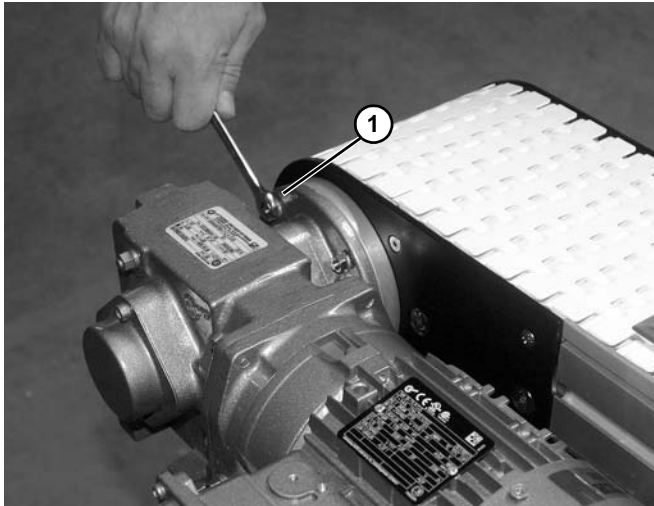
**Figure 131**

3. Install components reverse of removal.

# Preventive Maintenance and Adjustment

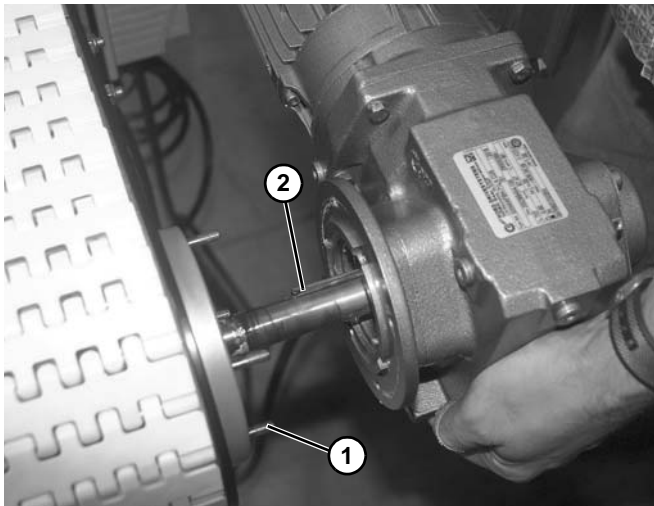
## Gearmotor Drive

1. Remove four nuts (**Figure 132, item 1**) securing drive motor.



**Figure 132**

2. Remove drive motor off of motor mounting flange studs (**Figure 133, item 1**), while noting key (**Figure 133, item 2**) on motor drive shaft.

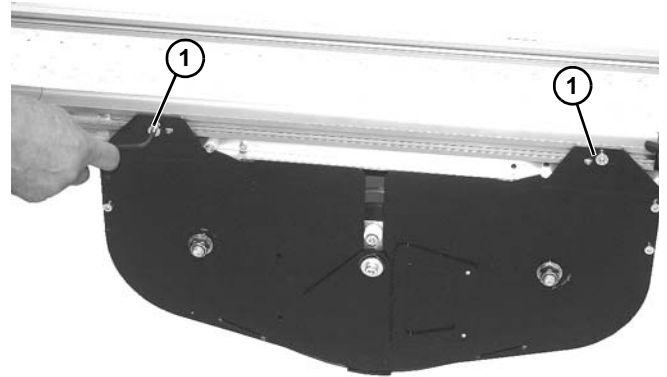


**Figure 133**

3. Replace gearmotor drive.

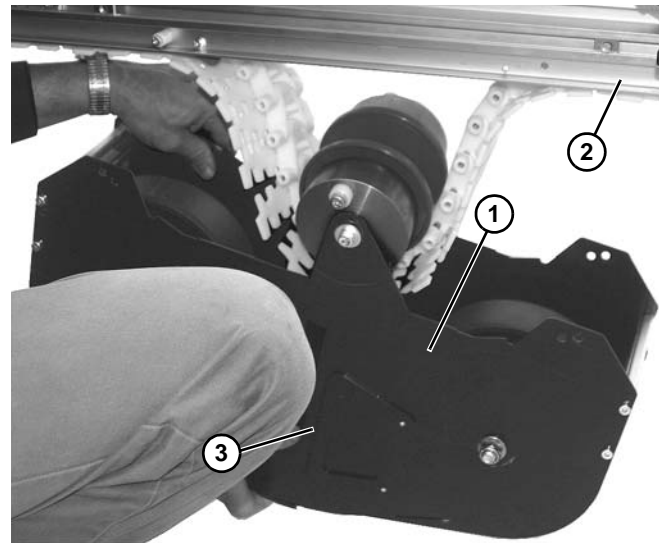
## Weighted Take-Up

1. Remove two socket head screws (**Figure 134, item 1**) on each side securing assembly to frame.



**Figure 134**

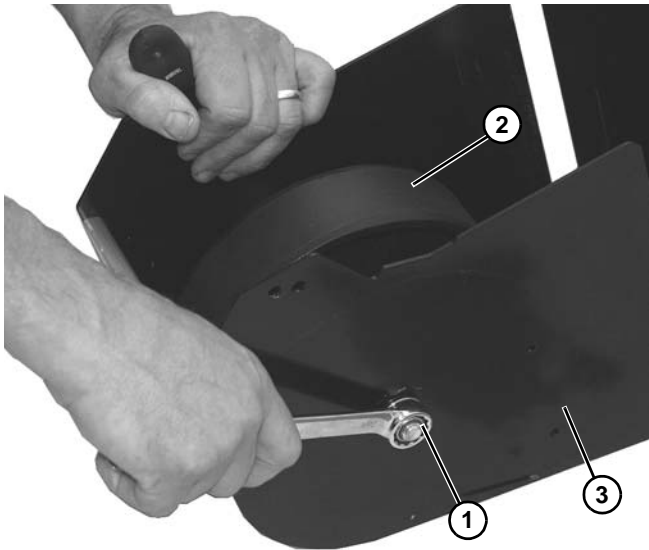
2. Lower weighted take up assembly (**Figure 135, item 1**) from conveyor (**Figure 135, item 2**) by disengaging locking teeth (**Figure 135, item 3**) on both sides.



**Figure 135**

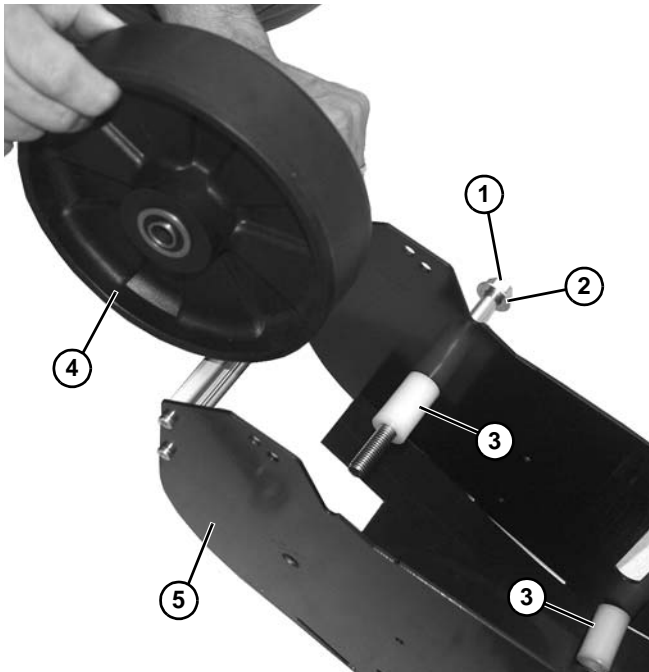
# Preventive Maintenance and Adjustment

3. Use two wrenches to remove nut (**Figure 136, item 1**) on bolt securing wheel (**Figure 136, item 2**) onto weighted take up assembly housing (**Figure 136, item 3**).



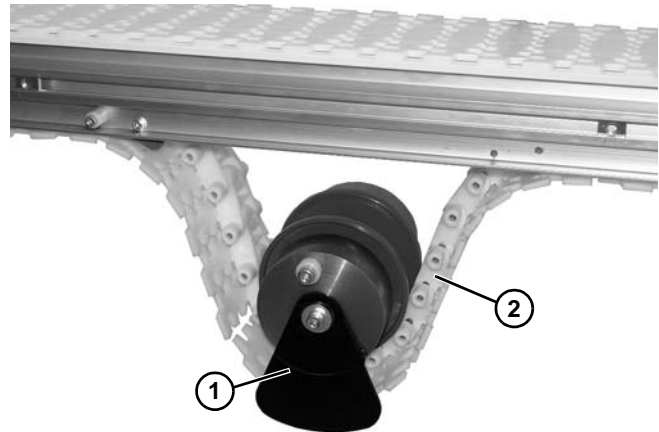
**Figure 136**

4. Remove bolt (**Figure 137, item 1**), washer (**Figure 137, item 2**), two spacers (**Figure 137, item 3**), and wheel (**Figure 137, item 4**) from take up assembly housing (**Figure 137, item 5**).



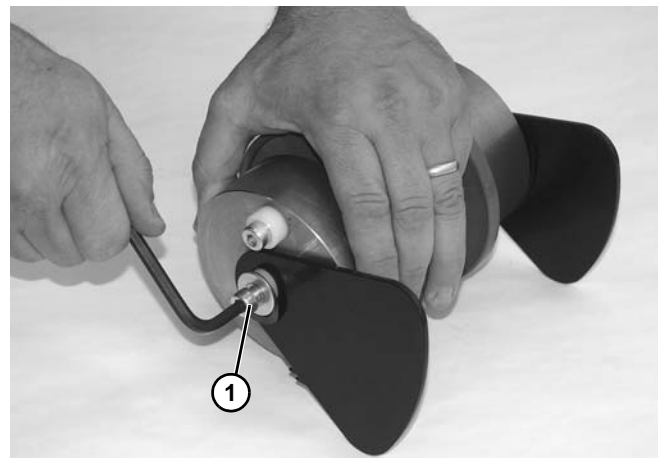
**Figure 137**

5. Remove idler pulley assembly (**Figure 138, item 1**) from belt (**Figure 138, item 2**).



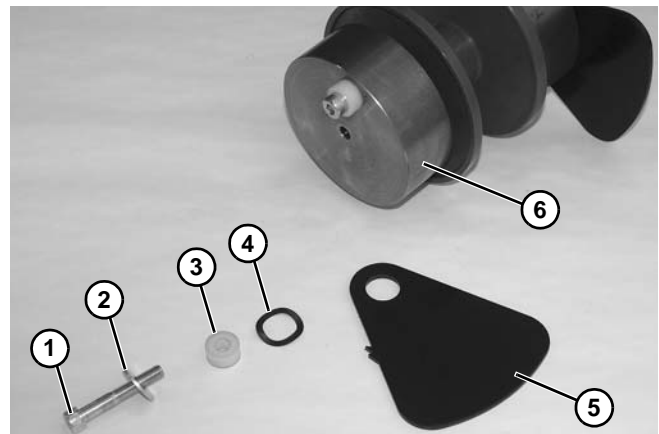
**Figure 138**

6. Remove socket head screw (**Figure 139, item 1**) from end of idler pulley assembly.



**Figure 139**

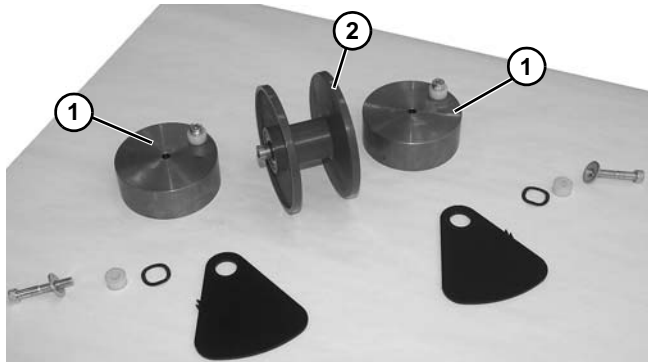
7. Remove bolt (**Figure 140, item 1**), washer (**Figure 140, item 2**), spacer (**Figure 140, item 3**), wave washer (**Figure 140, item 4**), and plate (**Figure 140, item 5**) from end of idler assembly (**Figure 140, item 6**).



**Figure 140**

# Preventive Maintenance and Adjustment

- Repeat on opposite side.
- Remove weights (**Figure 141, item 1**) from each side of pulley (**Figure 141, item 2**).

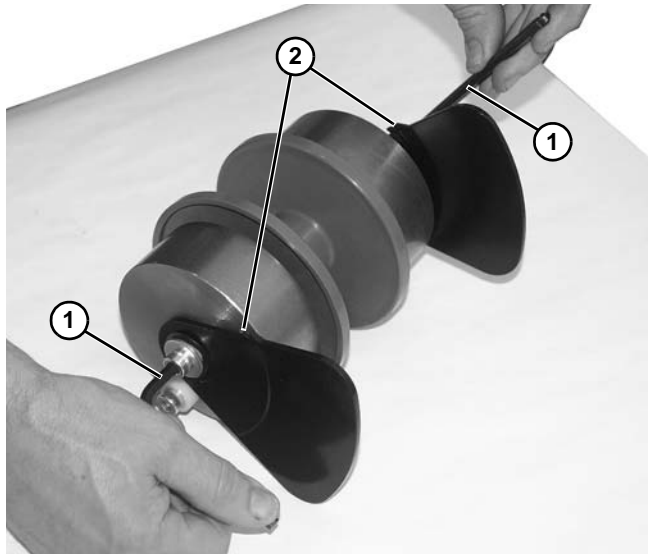


**Figure 141**

- Install components reverse of removal, using two hex wrenches (**Figure 142, item 1**) on each side of idler assembly to tighten components.

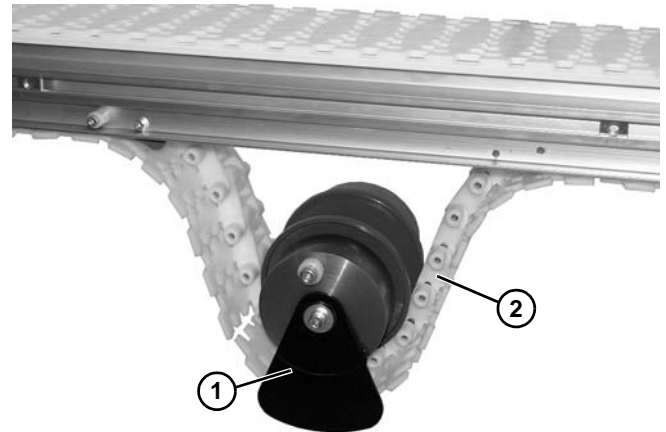
## NOTE

*Be certain that notches (**Figure 142, item 2**) on both plates are on top side, and spacers are in same orientation, as shown, before tightening components.*



**Figure 142**

- Install idler pulley assembly (**Figure 143, item 1**) onto conveyor in belt loop (**Figure 143, item 2**).



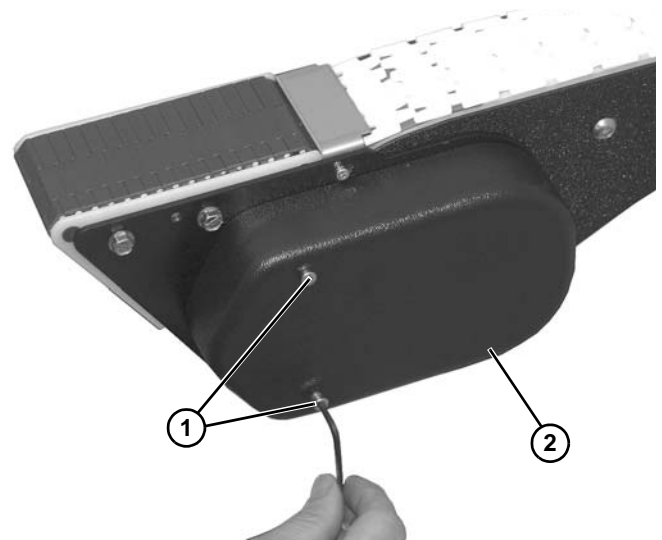
**Figure 143**

- Install remaining components reverse of removal. (For installation instructions, refer to “Weighted Take-Up” on page 21 in the Installation section.)

## Power Transfer

### Removal

- Remove two socket head screws (**Figure 144, item 1**) and cover (**Figure 144, item 2**) from power transfer assembly.



**Figure 144**

# Preventive Maintenance and Adjustment

- Loosen two socket head screws (Figure 145, item 1) holding tensioning pulley (Figure 145, item 2) onto timing belt (Figure 145, item 3).

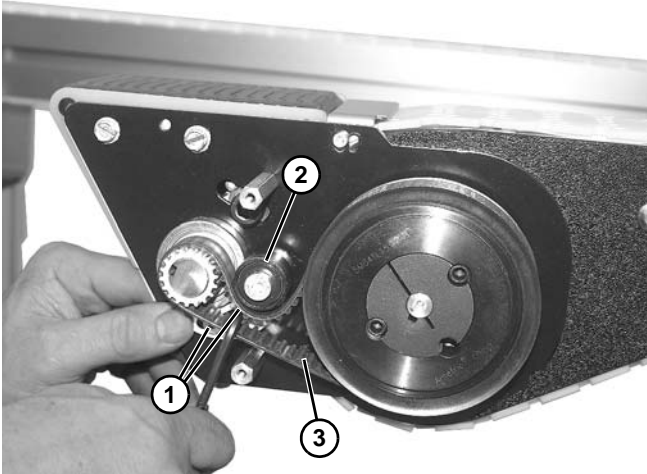


Figure 145

- Lift slightly on belt (Figure 148, item 1) and push pin (Figure 148, item 2) out of belt.

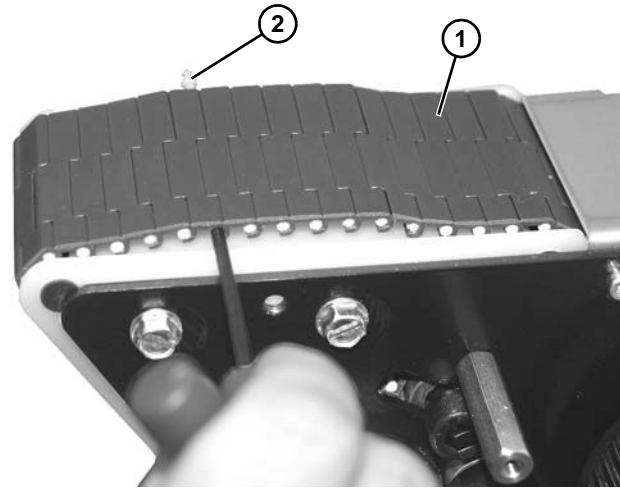


Figure 148

- Remove timing belt (Figure 145, item 3) from assembly.
- Loosen idler socket head screw (Figure 146, item 1) on both sides of the conveyor.

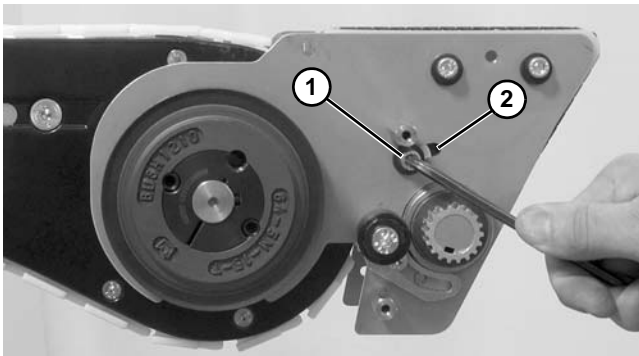


Figure 146

- Slide idler assembly within slot (Figure 146, item 2) to remove tension on belt.
- Remove two socket head screws (Figure 147, item 1) and pinch guard (Figure 147, item 2).

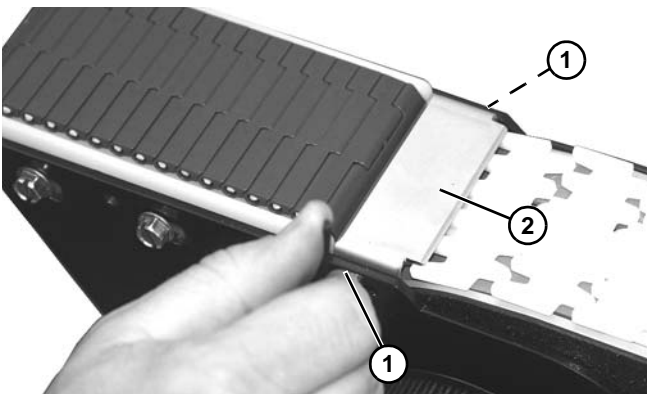


Figure 147

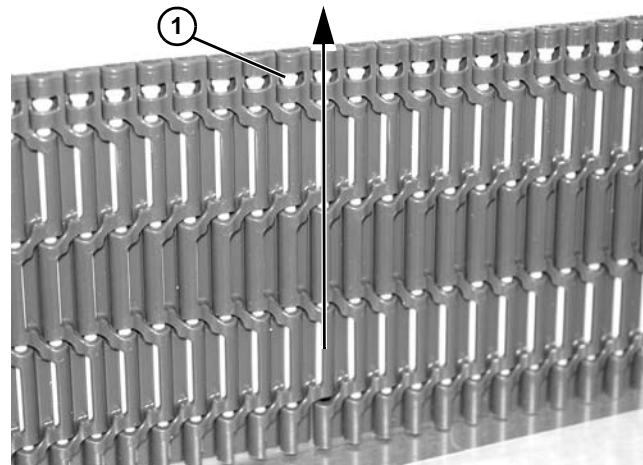


Figure 149

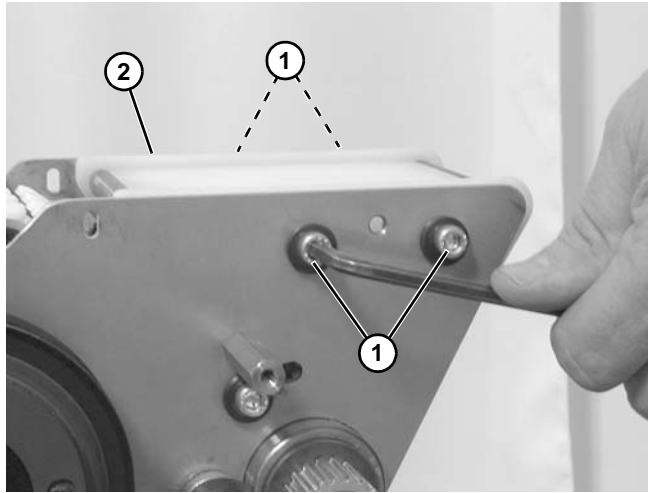
## NOTE

Note that head of pin (Figure 149, item 1) should be removed in direction shown.

- Remove belt.

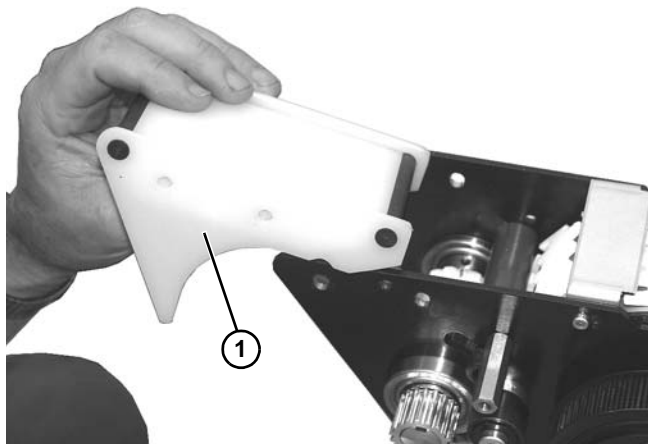
# Preventive Maintenance and Adjustment

9. Remove four socket head screws (**Figure 150, item 1**) holding wear bar assembly (**Figure 150, item 2**) onto power transfer.



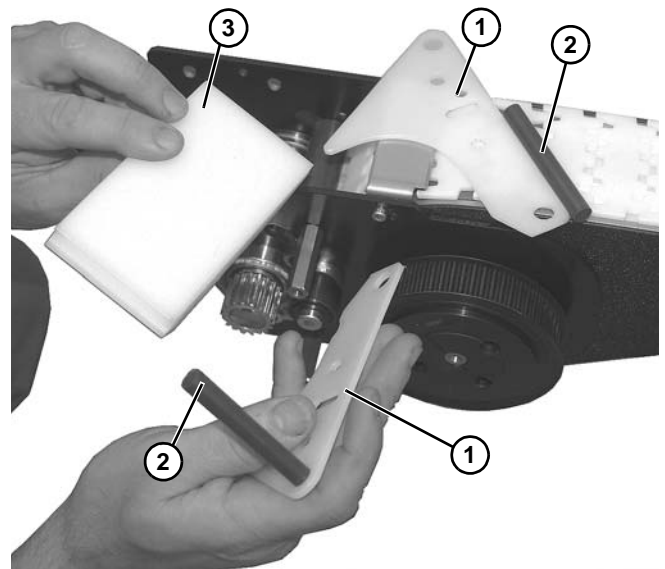
**Figure 150**

10. Remove wear bar assembly (**Figure 151, item 1**) from power transfer.



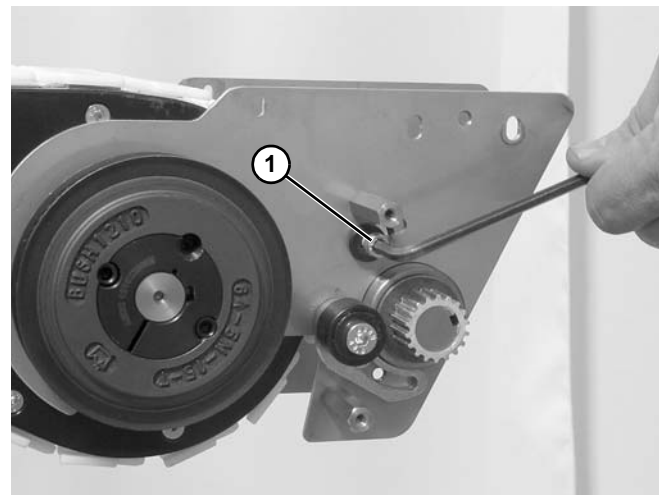
**Figure 151**

11. Disassemble side guide plates (**Figure 152, item 1**), wear rods (**Figure 152, item 2**), and wear bar (**Figure 152, item 3**). Replace worn components.



**Figure 152**

12. Remove socket head screw (**Figure 153, item 1**) on both sides of the conveyor and remove idler assembly.



**Figure 153**

13. Replace idler assembly (if worn), and install socket head screws to secure.

# Preventive Maintenance and Adjustment

14. Loosen two set screws (Figure 154, item 1) on two bearings (Figure 154, item 2).

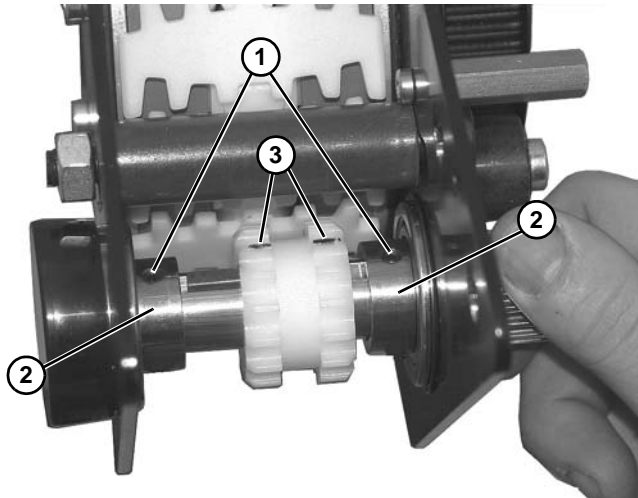


Figure 154

15. Loosen sprocket set screws (Figure 154, item 3).
16. Remove drive shaft (Figure 155, item 1), making certain not to lose key (Figure 155, item 2) when removing gear (Figure 155, item 3).

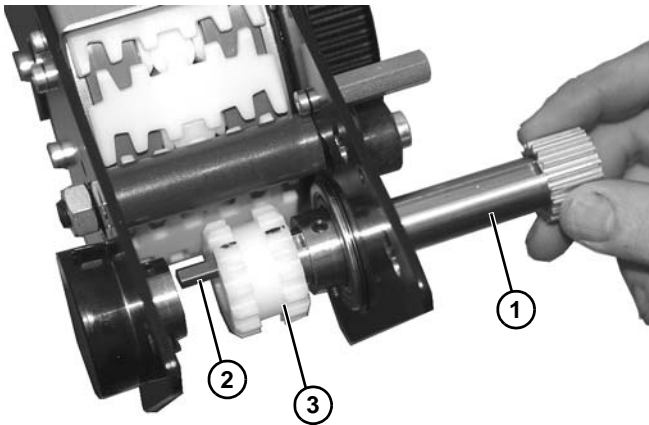


Figure 155

17. Remove key (Figure 156, item 1) from sprocket (Figure 156, item 2).

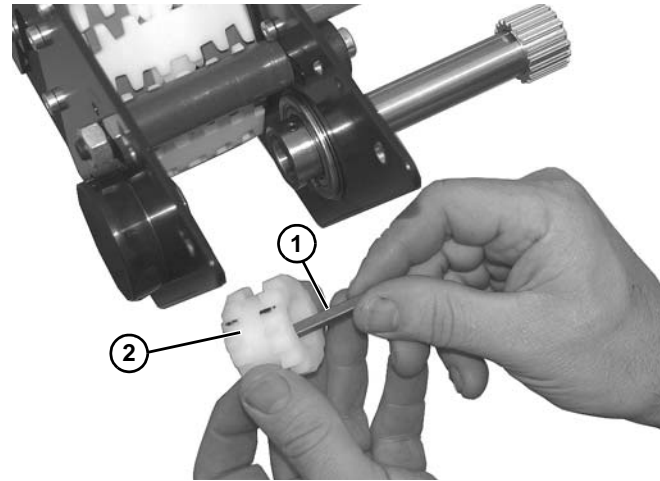


Figure 156

18. Replace worn drive sprockets and bearings.

## Installation

1. Install drive shaft (Figure 157, item 1) on two bearings (Figure 157, item 2) and press outward as shown.

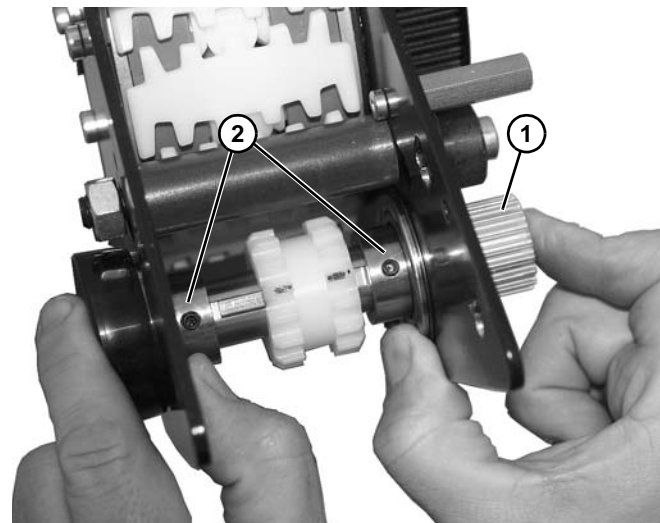
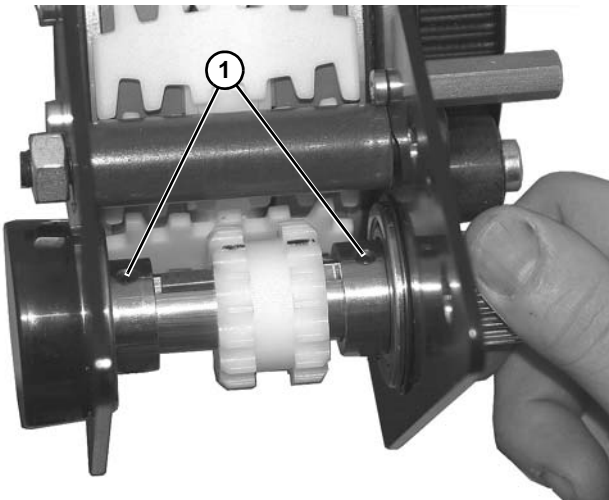


Figure 157

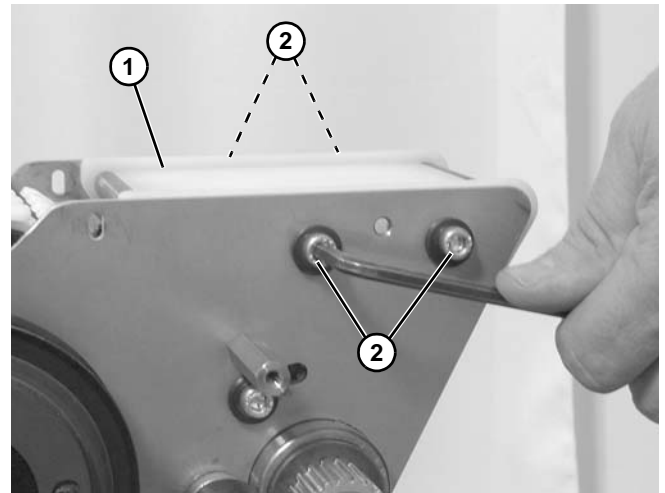
# Preventive Maintenance and Adjustment

2. Secure drive shaft onto bearings with two set screws (Figure 158, item 1).



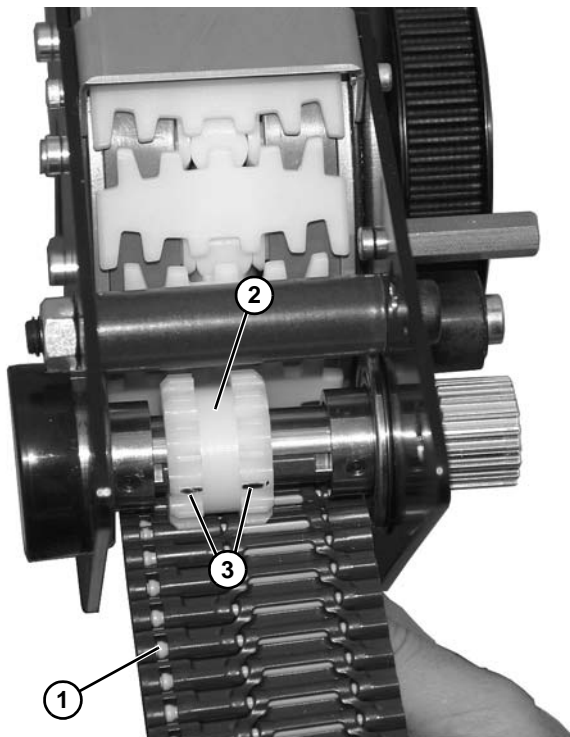
**Figure 158**

5. Install wear bar assembly (Figure 160, item 1) with four socket head screws (Figure 160, item 2).



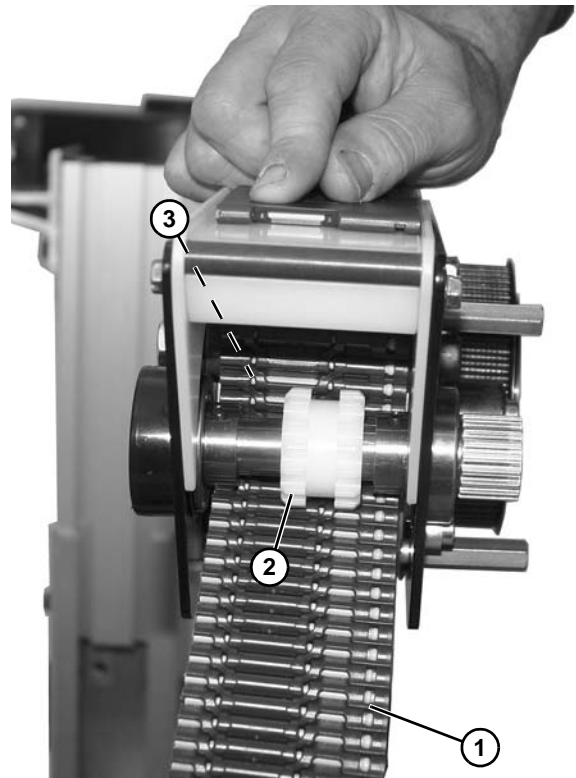
**Figure 160**

3. Raise belt (Figure 159, item 1) into position, and move gear (Figure 159, item 2) so that cogs line up with belt, as shown.



**Figure 159**

6. Guide belt (Figure 161, item 1) through idler assembly with belt routing under gear (Figure 161, item 2) and over wear tube (Figure 161, item 3).



**Figure 161**

4. Tighten sprocket with set screws (Figure 159, item 3) in proper alignment with belt (Figure 159, item 1).

# Preventive Maintenance and Adjustment

7. Bring ends of belt together and install pin (Figure 162, item 1).

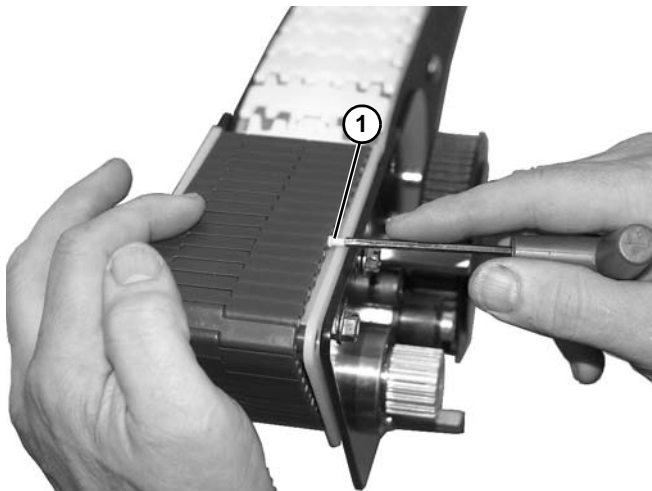


Figure 162

8. Install pinch guard (Figure 163, item 1) with two socket head screws (Figure 163, item 2).

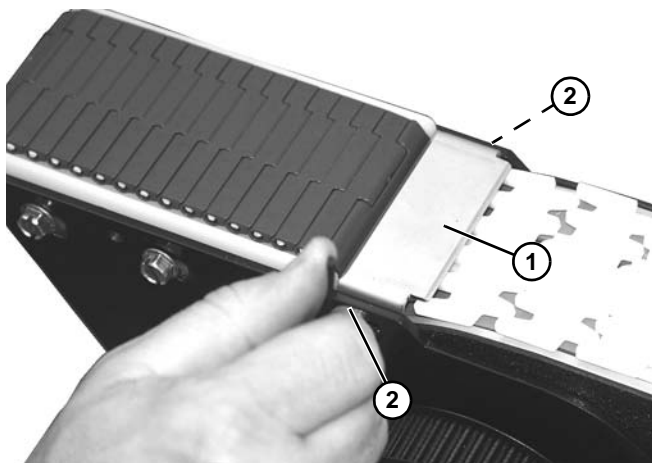


Figure 163

9. Slide idler assembly within slot (Figure 164, item 1) only enough to remove excess slack from belt (Figure 164, item 2). Tighten socket head screws (Figure 164, item 3).

## CAUTION

DO NOT overtighten belt or excessive wear will occur.

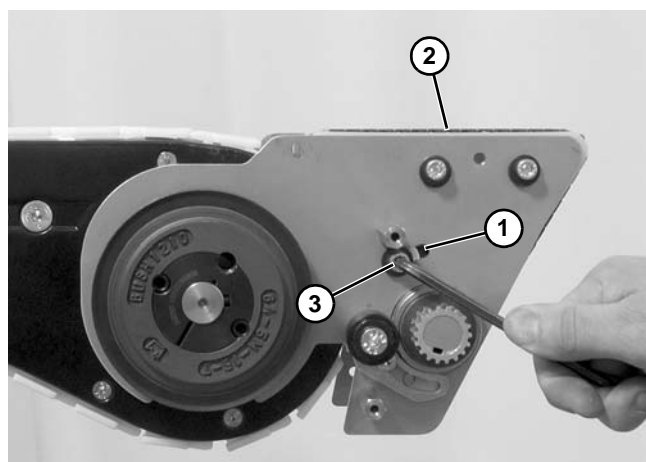


Figure 164

10. Rotate drive shaft (Figure 165, item 1) to verify tightness of belt (Figure 165, item 2). Belt should turn freely. Loosen idler socket head screw (Figure 165, item 3) and adjust, if necessary.

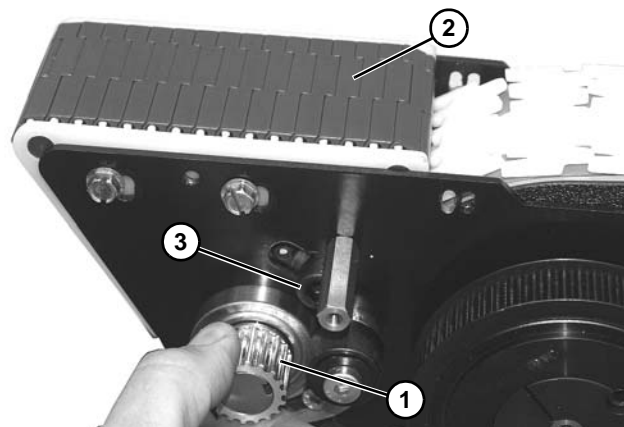
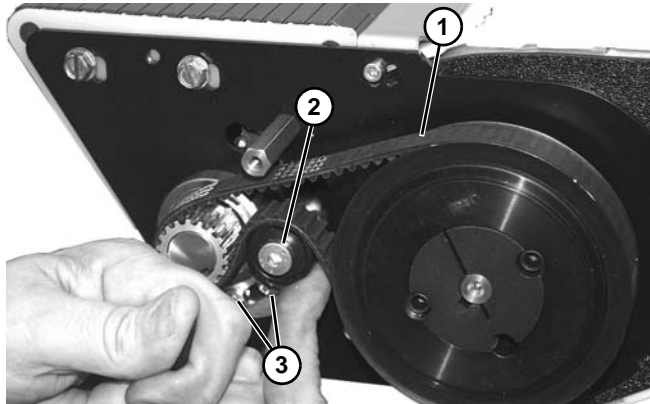


Figure 165

11. Install timing belt:

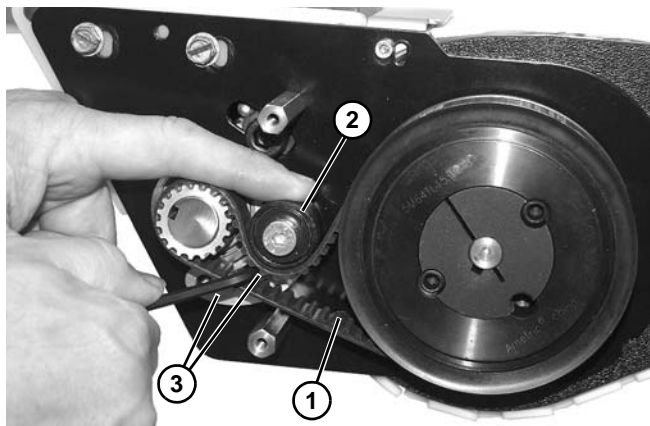
# Preventive Maintenance and Adjustment

- On idler end, route and install belt (**Figure 166, item 1**) as shown. Press up on tensioner (**Figure 166, item 2**) and tighten two socket head screws (**Figure 166, item 3**).



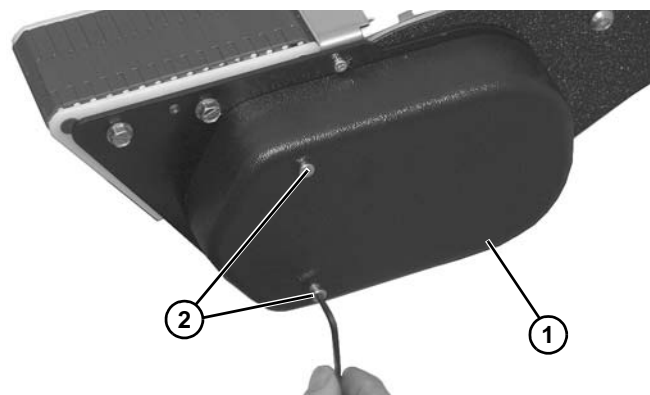
**Figure 166**

- On drive end, route and install belt (**Figure 167, item 1**) as shown. Press down on tensioner (**Figure 167, item 2**) and tighten two socket head screws (**Figure 167, item 3**).



**Figure 167**


12. Install cover (**Figure 168, item 1**) with two socket head screws (**Figure 168, item 2**).



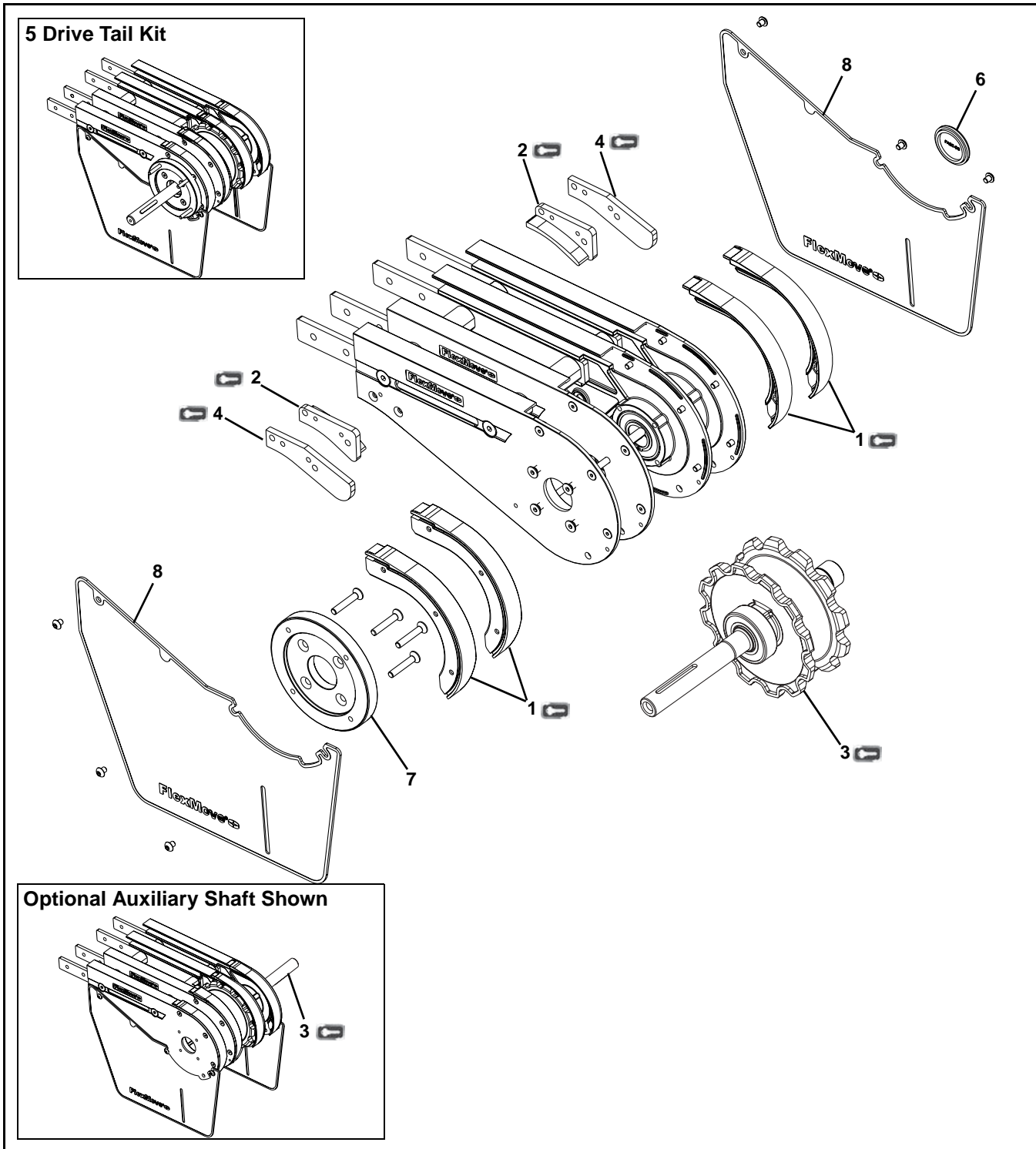
**Figure 168**

# Service Parts

## NOTE

For replacement parts other than those shown in this section, contact an authorized Dorner distributor or Dorner directly. Recommended Critical Service Parts and Kits are identified by the Key Service Parts symbol . Dorner recommends keeping these parts on hand.

## Drive Tail



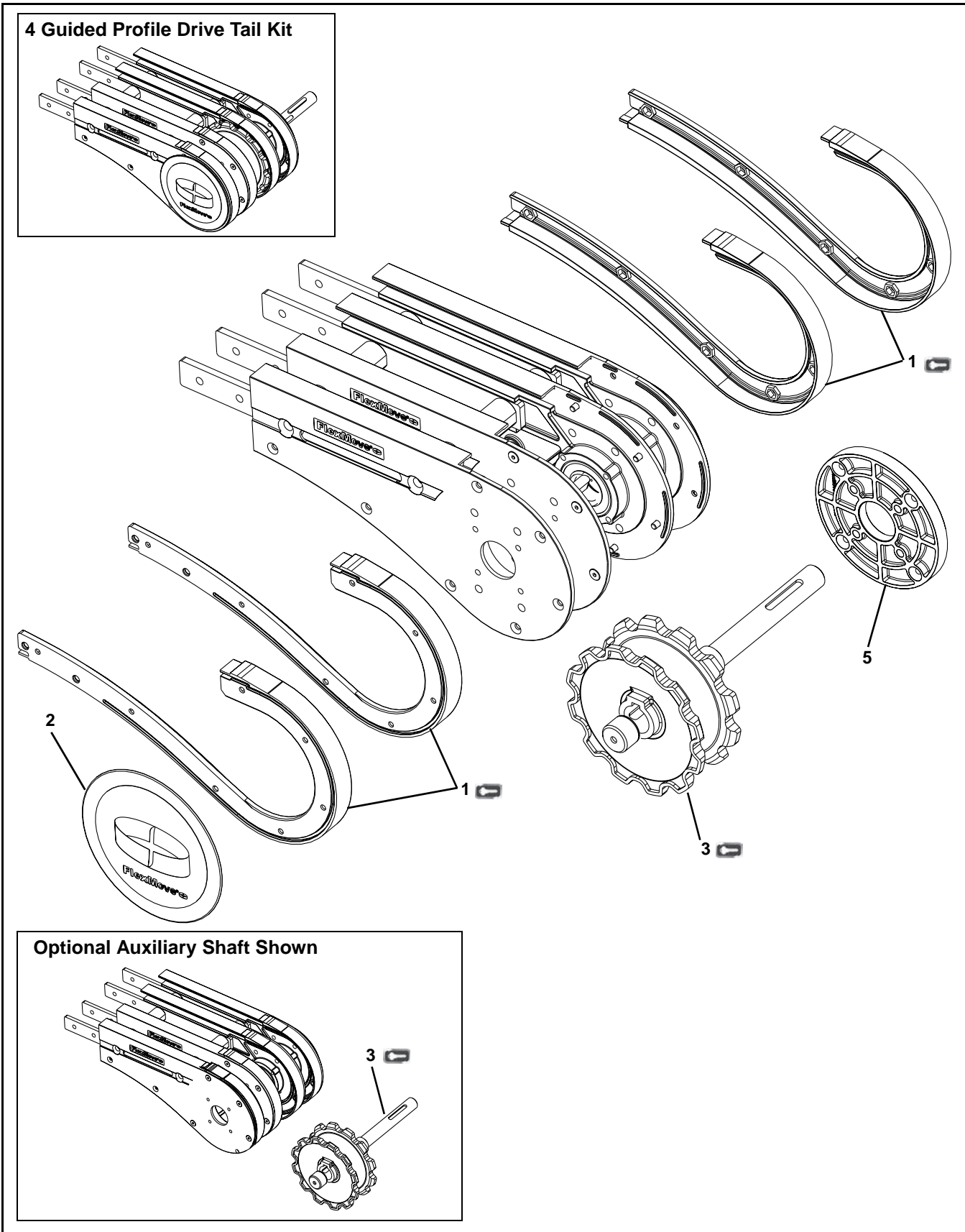
# Service Parts

Item	Part Number	Description
1	FMD83101-A	Retaining Guide Set (2 Pairs)
2	FU-A2016	Belt Capture Guide Set (Pair)
3	205700-EN-260	Standard Load E-Drive 3/4" Spindle Shaft Assembly
	205700-EA-260	Standard Load E-Drive 3/4" Spindle Shaft Assembly with Auxiliary Shaft
	205700-FN-260	Standard Load 20 mm Spindle Shaft Assembly
	205700-FA-260	Standard Load 20 mm Spindle Shaft Assembly with Auxiliary Shaft
	205700-AN-260	Auxiliary Spindle Shaft Assembly
	205700-AA-260	Dual Auxiliary Spindle Shaft Assembly
4	FU-A2017	Drive Return Guide Set (Pair)
5	FVDD-A260-EL	Standard Load E-Drive 3/4" Drive Tail Kit with Shaft in the 'A' Position
	FVDD-A260-ER	Standard Load E-Drive 3/4" Drive Tail Kit with Shaft in the 'D' Position
	FVDD-A260-ELA	Standard Load E-Drive 3/4" Drive Tail Kit with Shaft in the 'A' Position and Auxiliary Shaft
	FVDD-A260-ERA	Standard Load E-Drive 3/4" Drive Tail Kit with Shaft in the 'D' Position and Auxiliary Shaft
	FVDD-A260PT-EL	Standard Load E-Drive 3/4" Drive Tail Kit with Shaft in the 'A' Position and Power Transfer
	FVDD-A260PT-ER	Standard Load E-Drive 3/4" Drive Tail Kit with Shaft in the 'D' Position and Power Transfer
	FVDD-A260-0L	Standard Load 20 mm Drive Tail Kit with Shaft in the 'A' Position
	FVDD-A260-0R	Standard Load 20 mm Drive Tail Kit with Shaft in the 'D' Position
	FVDD-A260-0LA	Standard Load 20 mm Drive Tail Kit with shaft in the 'A' Position and Auxiliary Shaft
	FVDD-A260-0RA	Standard Load 20 mm Drive Tail Kit with shaft in the 'D' Position and Auxiliary Shaft
	FVDD-A260PT-0L	Standard Load 20 mm Drive Tail Kit with Shaft in the 'A' Position and Power Transfer
	FVDD-A260PT-0R	Standard Load 20 mm Drive Tail Kit with Shaft in the 'D' Position and Power Transfer
	FVDD-A260-AA	Auxiliary Tail Kit with two Auxiliary Shafts
	FVDD-A260-AL	Auxiliary Tail Kit with Shaft in the 'A' Position
FVDD-A260-AR	Auxiliary Tail Kit with Shaft in the 'D' Position	

Item	Part Number	Description
6	FAEC-DS	Plug
7	FLG-120-SF	Drive Flange
	207242	Drive Flange for Power Transfer
8	CP1005-1-SF	Guard Plate (Pair - with screws)
Service parts can be obtained through your distributor or directly from Dorner Mfg. Corp. (800) 397-8664 or customerservice@dorner.com		

# Service Parts

## Guided Profile (GP) Drive Tail



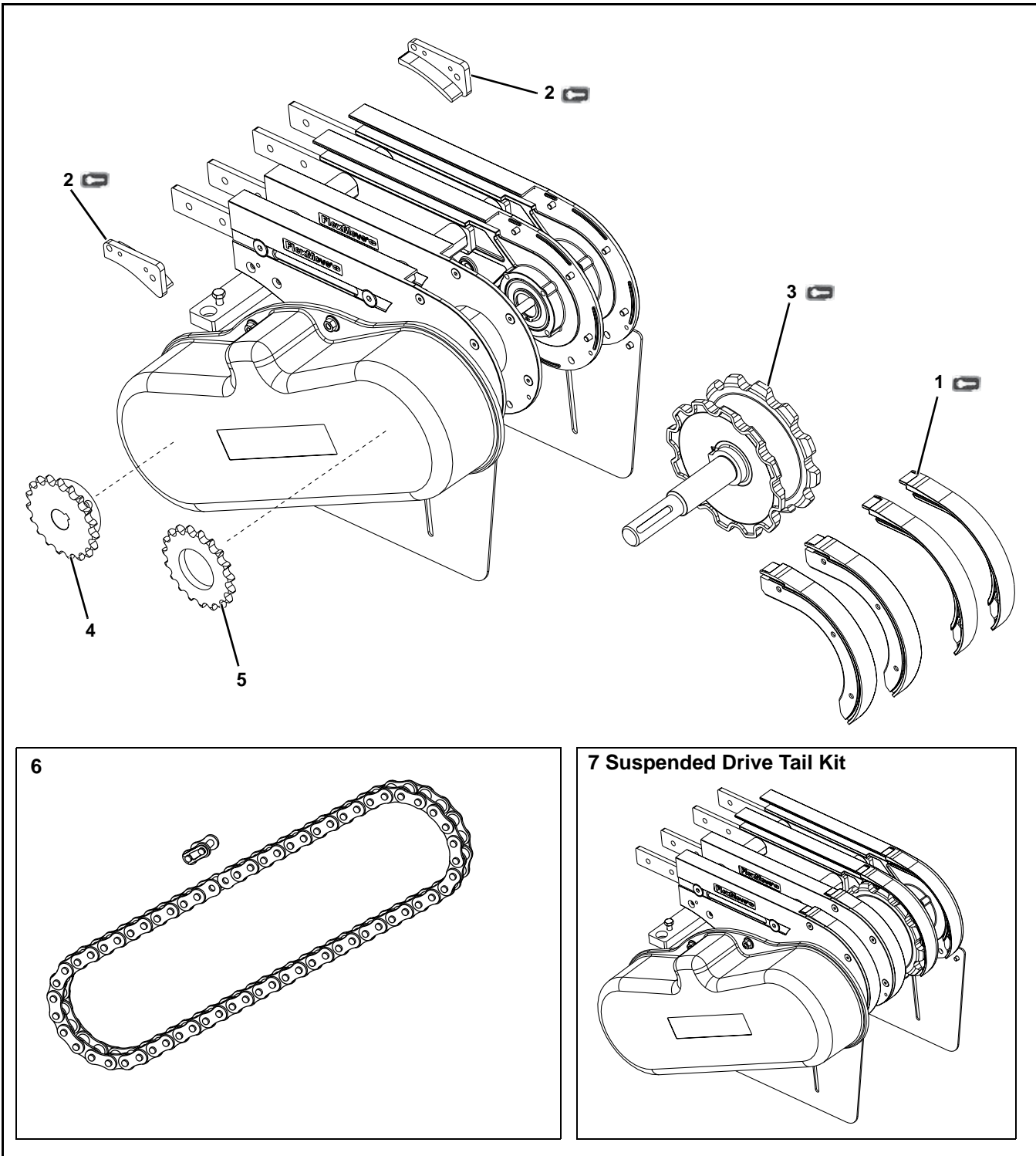
# Service Parts

Item	Part Number	Description
1	FME83001-A	Retaining Guide Set (2 Pairs)
2	FAEC-IE-SF	Idler Tail Cover (x10)
3	205700-EN-260	Standard Load E-Drive 3/4" Spindle Shaft Assembly
	205700-EA-260	Standard Load E-Drive 3/4" Spindle Shaft Assembly with Auxiliary Shaft
	205700-FN-260	Standard Load 20 mm Spindle Shaft Assembly
	205700-FA-260	Standard Load 20 mm Spindle Shaft Assembly with Auxiliary Shaft
	205700-AN-260	Auxiliary Spindle Shaft Assembly
	205700-AA-260	Dual Auxiliary Spindle Shaft Assembly
4	FVDD-A260GP-EL	Standard Load E-Drive 3/4" Drive Tail Kit with Shaft in the 'A' Position
	FVDD-A260GP-ER	Standard Load E-Drive 3/4" Drive Tail Kit with Shaft in the 'D' Position
	FVDD-A260GP-ELA	Standard Load E-Drive 3/4" Drive Tail Kit with Shaft in the 'A' Position and Auxiliary Shaft
	FVDD-A260GP-ERA	Standard Load E-Drive 3/4" Drive Tail Kit with Shaft in the 'D' Position and Auxiliary Shaft
	FVDD-A260GPPT-EL	Standard Load E-Drive 3/4" Drive Tail Kit with Shaft in the 'A' Position and Power Transfer
	FVDD-A260GPPT-ER	Standard Load E-Drive 3/4" Drive Tail Kit with Shaft in the 'D' Position and Power Transfer
	FVDD-A260GP-0L	Standard Load 20 mm Drive Tail Kit with Shaft in the 'A' Position
	FVDD-A260GP-0R	Standard Load 20 mm Drive Tail Kit with Shaft in the 'D' Position
	FVDD-A260GP-0LA	Standard Load 20 mm Drive Tail Kit with Shaft in the 'A' Position and Auxiliary Shaft
	FVDD-A260GP-0RA	Standard Load 20 mm Drive Tail Kit with Shaft in the 'D' Position and Auxiliary Shaft
	FVDD-A260GPPT-0L	Standard Load 20 mm Drive Tail Kit with Shaft in the 'A' Position and Power Transfer
	FVDD-A260GPPT-0R	Standard Load 20 mm Drive Tail Kit with Shaft in the 'D' Position and Power Transfer
	FVDD-A260GP-AA	Auxiliary Tail Kit with two Auxiliary Shafts
	FVDD-A260GP-AL	Auxiliary Tail Kit with Shaft in the 'A' Position
FVDD-A260GP-AR	Auxiliary Tail Kit with Shaft in the 'D' Position	

Item	Part Number	Description
5	FLG-120-SF	Drive Flange
	207242	Drive Flange for Power Transfer
Service parts can be obtained through your distributor or directly from Dorner Mfg. Corp. (800) 397-8664 or customerservice@dorner.com		

# Service Parts

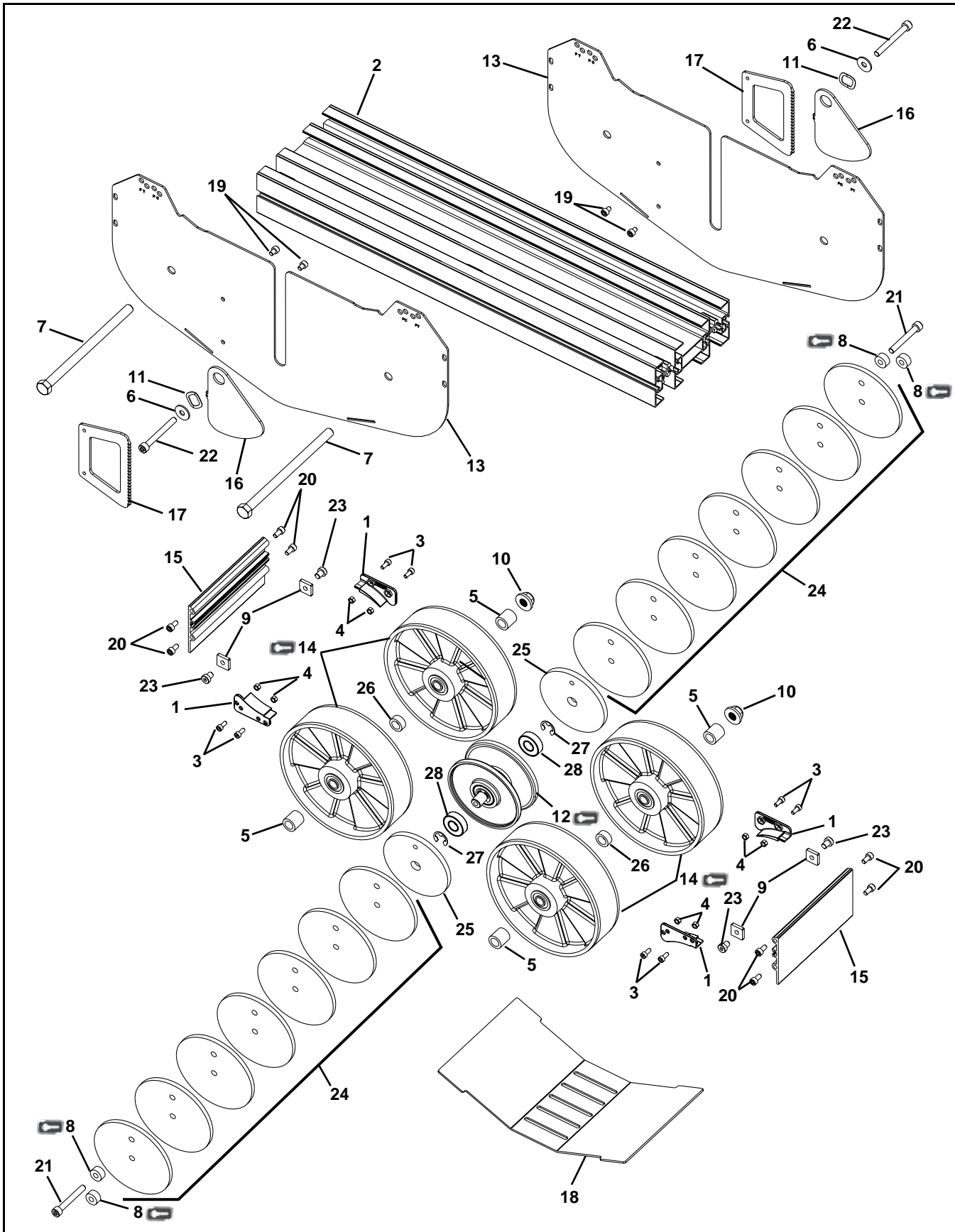
## FVSD-A260 Suspended Drive



Item	Part Number	Description
1	FUD180101-A	Retaining Guide Set (Pair)
2	FUD180102-A	Belt Capture Guide Set (Pair)
3	205700-AN-260	Auxiliary Spindle Shaft Assembly
4	RS08BX19T-20	Sprocket, Solid (19T)
5	FATL-250	Torque Limiter Sprocket (Max Pull 844N)
6	FRS008B-64LK	Roller Chain
7	FVSD-A260-0L	Suspended Drive Tail Kit with Shaft in the 'A' Position
	FVSD-A260-0R	Suspended Drive Tail Kit with Shaft in the 'D' Position
	FVSD-A260GP-0L	Suspended Guided Profile Drive Tail Kit with Shaft in the 'A' Position
	FVSD-A260GP-0R	Suspended Guided Profile Drive Tail Kit with Shaft in the 'D' Position
Service parts can be obtained through your distributor or directly from Dorner Mfg. Corp. (800) 397-8664 or customerservice@dorner.com		




# Service Parts

## Weighted Take-Up



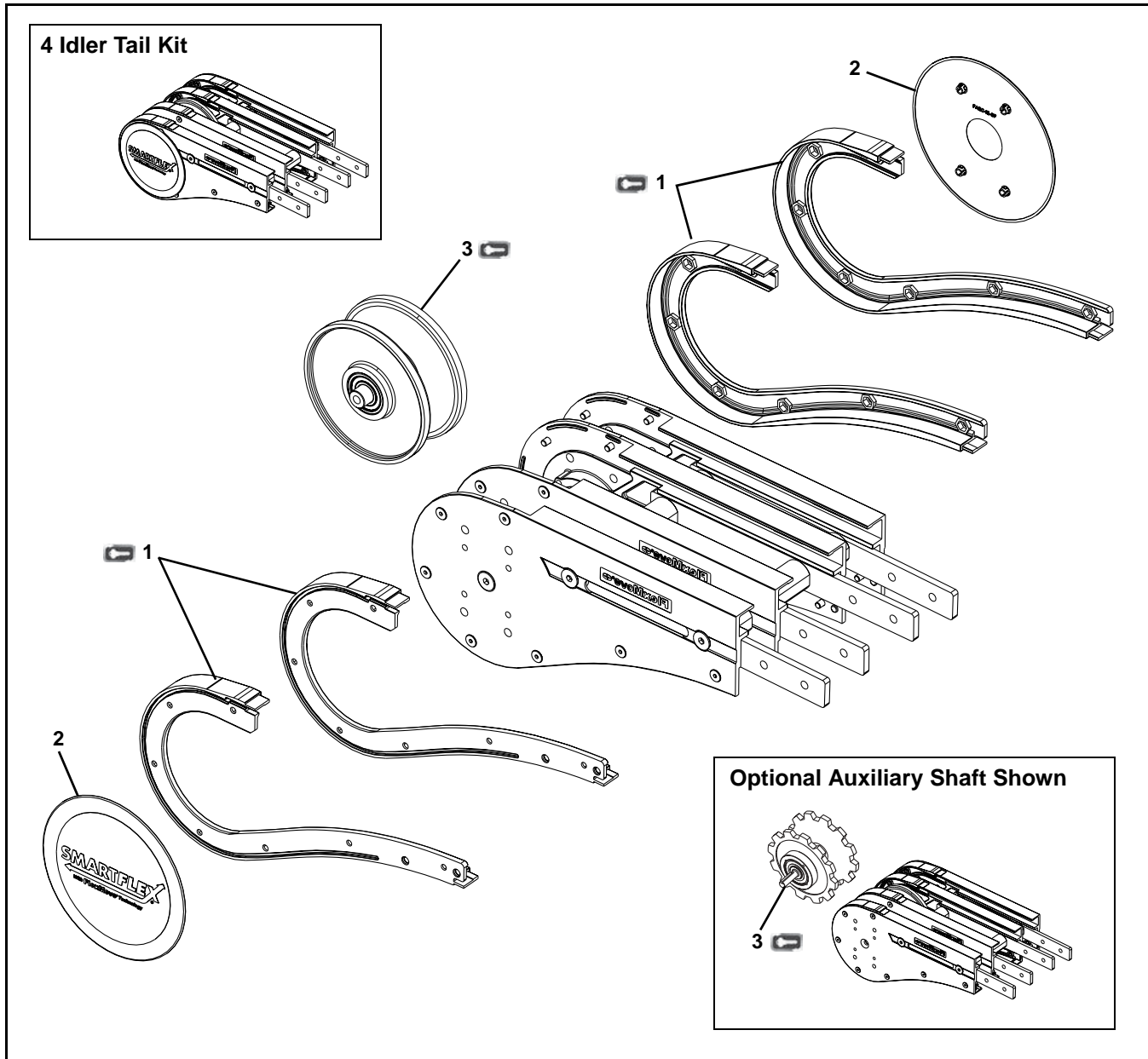
FlexMove FV (260 mm) Conveyor System

# Service Parts

Item	Part Number	Description
1	FMD83102-A	Belt Capture Guide Set (Pair)
2	207198-260	Conveyor Section
3	920512M	Socket Head Screw, M5-.80 x 12 mm
4	990501M	Hex Nut, M5-0.80
5	518393-00084	Spacer, 0.55" x 0.844"
6	807-1760	Washer
7	807-3726	Hex Bolt, 1/2-13 x 8.0"
8 	807-2297	Nylon Spacer, 0.75" x 0.32" x 0.375"
9	FASN-M8	Square Nut, M8 (x50)
10	910-320	Lock Nut
11	807-2314	Spring Washer
12 	FVIM-A15	Idle Pulley Assembly
13	203330	Weighted Take-Up Plate
14 	203331	Wheel
15	203344-260	End Guard
16	203349	Latching Cover
17	203351	Ratchet Plate
18	207199-260	Bottom Guard
19	920608M	Socket Head Cap Screw, M6-1.00 x 8 mm
20	920612M	Socket Head Cap Screw, M6-1.00 x 12 mm
21	920860M	Socket Head Cap Screw, M8-1.25 x 60 mm
22	920870M	Socket Head Cap Screw, M8-1.25 x 70 mm
23	950810M	Low Head Cap Screw, M8-1.25 x 10 mm
24	207746	Weighted Take-Up Disk, 1/4"
25	207747	Weighted Take-Up Disk, 5/16"
26	518393-00038	Spacer, 0.55" x 0.375"
27	915-319	Retaining Ring
28	802-124	Bearing
<p>Service parts can be obtained through your distributor or directly from Dorner Mfg. Corp. (800) 397-8664 or customerservice@dorner.com</p>		

# Service Parts

## Idler Tail

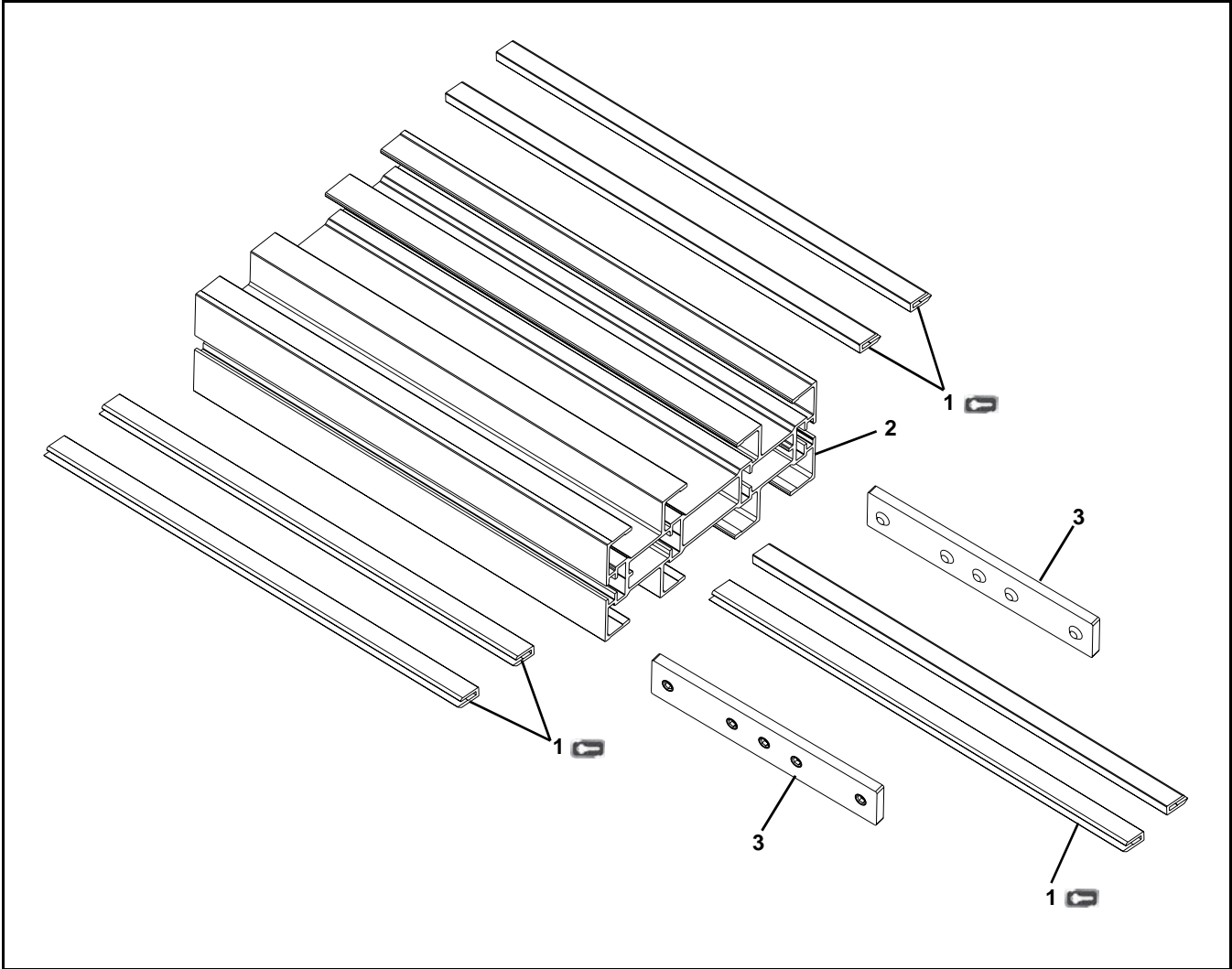


Item	Part Number	Description
1	FME83001-A	Retaining Guide Set (2 Pairs)
2	FAEC-IE	Idler Tail Cover (x10)
3	FUIM-A15	Idler Pulley Assembly
	205700-AN-260	Idler Pulley Assembly with Auxiliary Shaft

Item	Part Number	Description
4	FVIE-A260	Idler Tail Kit
	FVIE-A260-AL	Idler Tail Kit with Auxiliary Shaft in the 'A' Position
	FVIE-A260-AR	Idler Tail Kit with Auxiliary Shaft in the 'D' Position (Shown)
	FVIE-A260PT-L	Idler Tail Kit with Shaft in the 'A' Position and Power Transfer
	FVIE-A260PT-R	Idler Tail Kit with Shaft in the 'D' Position and Power Transfer

Service parts can be obtained through your distributor or directly from Dorner Mfg. Corp. (800) 397-8664 or [customerservice@dorner.com](mailto:customerservice@dorner.com)

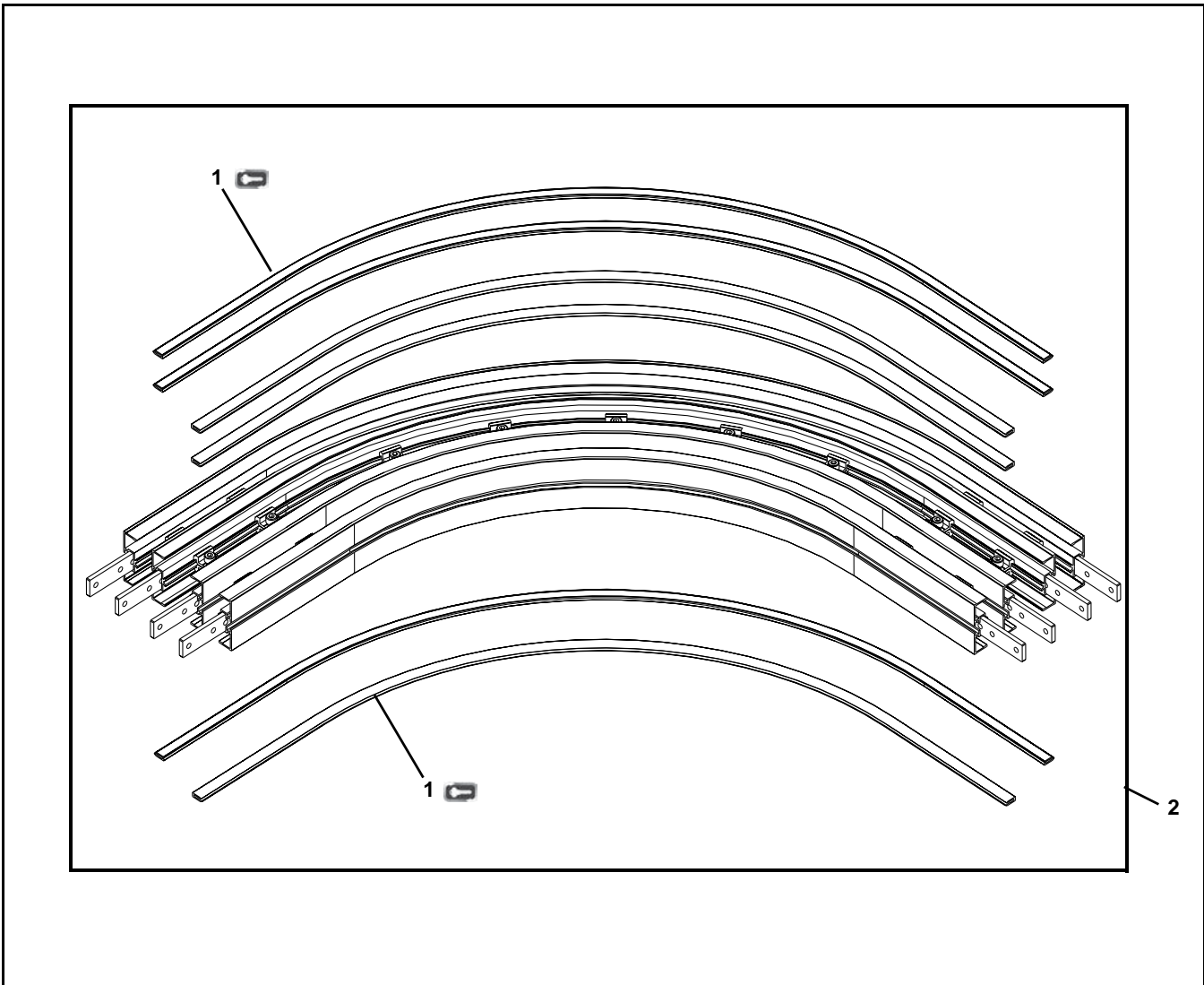
Frame Assembly




Item	Part Number	Description
1	See Slide Rail Section	Slide Rails
2	FVCB-3-LLLLL	Frame
3	FACS-25x140A	Connecting Bracket, w/Set Screws (x10)
<p>LLLLL = Part length in inches with two decimal places.                      Length Example: Length = 95.25" LLLLL = 09525</p>		
<p>Service parts can be obtained through your distributor or directly from Dorner Mfg. Corp. (800) 397-8664 or customerservice@dorner.com</p>		

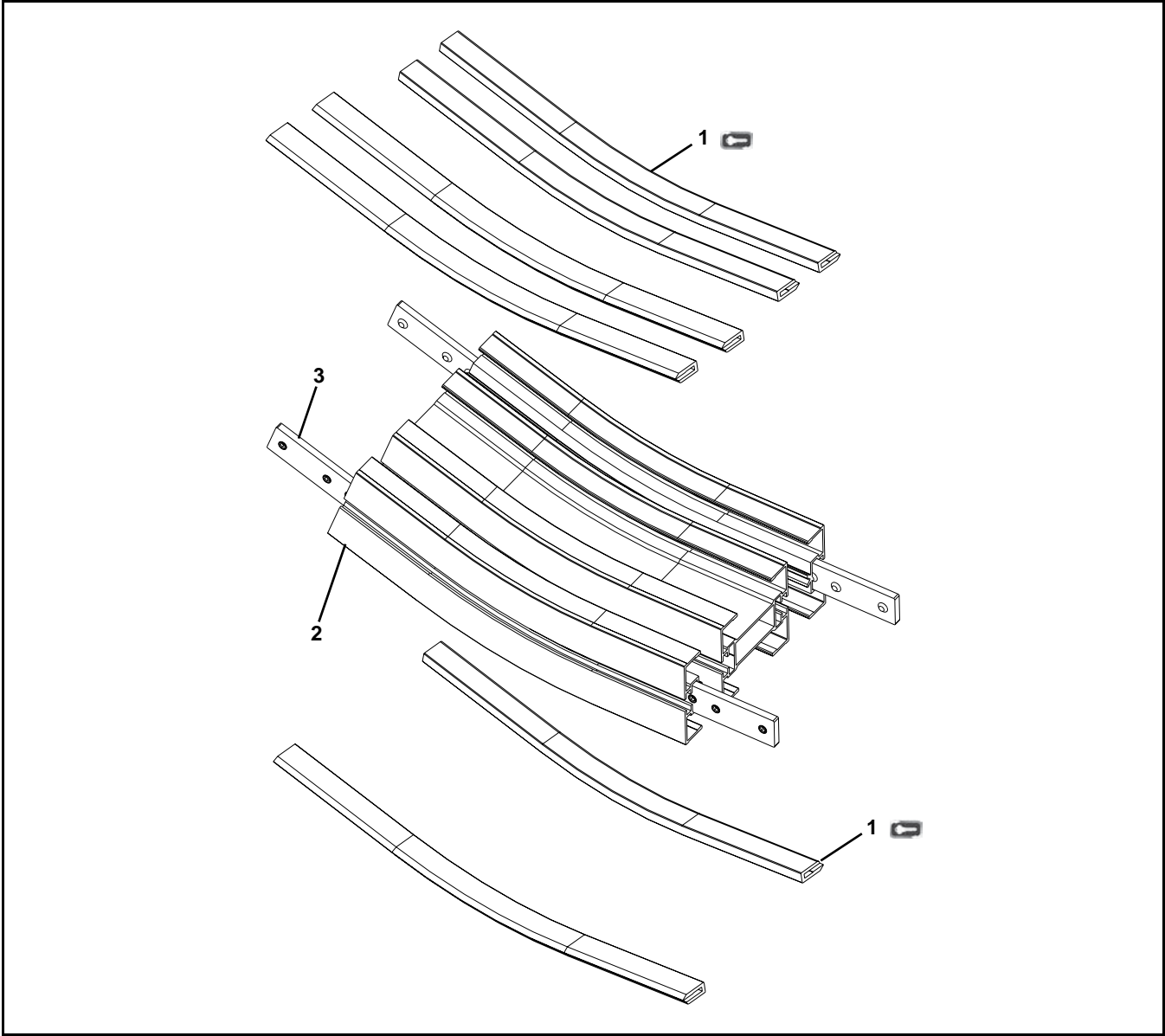
# Service Parts


## Curve Frame Assembly



Item	Part Number	Description
1 	See Slide Rail Section	Slide Rails
2	FVHB- $\Delta\Delta$ R700	700 mm Radius Plain Bend Curve Kit
	FVHB- $\Delta\Delta$ R1000	1000 mm Radius Plain Bend Curve Kit
$\Delta\Delta$ = Curve Angle: 30, 45, 60, 90		
Service parts can be obtained through your distributor or directly from Dorner Mfg. Corp. (800) 397-8664 or <a href="mailto:customerservice@dorner.com">customerservice@dorner.com</a>		

Knuckle Frame Assembly

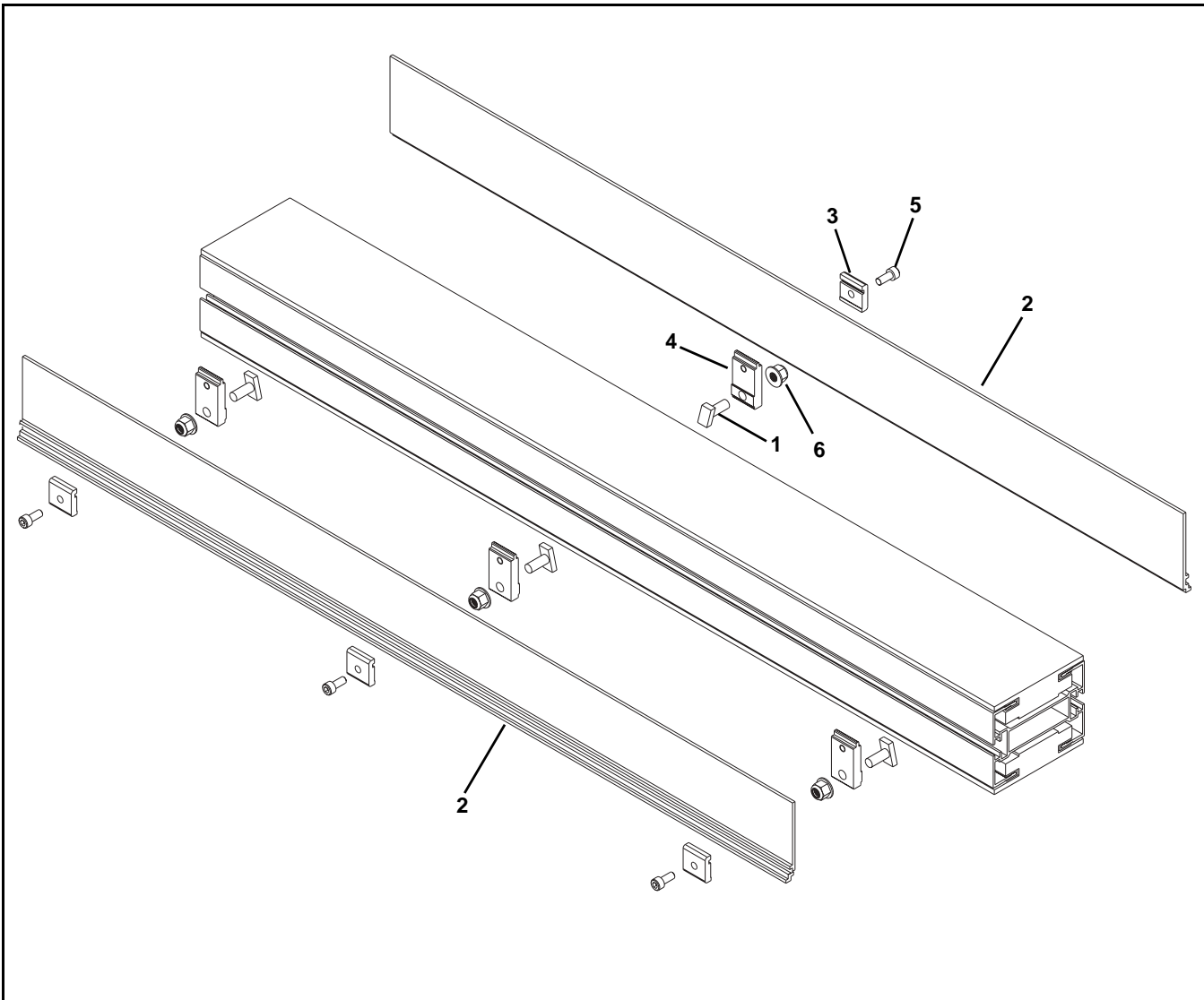


Item	Part Number	Description
1 	See Slide Rail Section	Slide Rails
2	FVVB-5R400	5° Knuckle Kit
	FVVB-7R400	7° Knuckle Kit
	FVVB-10R400	10° Knuckle Kit
	FVVB-15R400	15° Knuckle Kit
	FVVB-20R400	20° Knuckle Kit
	FVVB-30R400	30° Knuckle Kit
	FVVB-45R400	45° Knuckle Kit
	FVVB-60R400	60° Knuckle Kit
	FVVB-90R400	90° Knuckle Kit
3	FVCS-25x140A	Connecting Bracket, w/Set Screws (x10)

Service parts can be obtained through your distributor or directly from Dorner Mfg. Corp. (800) 397-8664 or customerservice@dorner.com

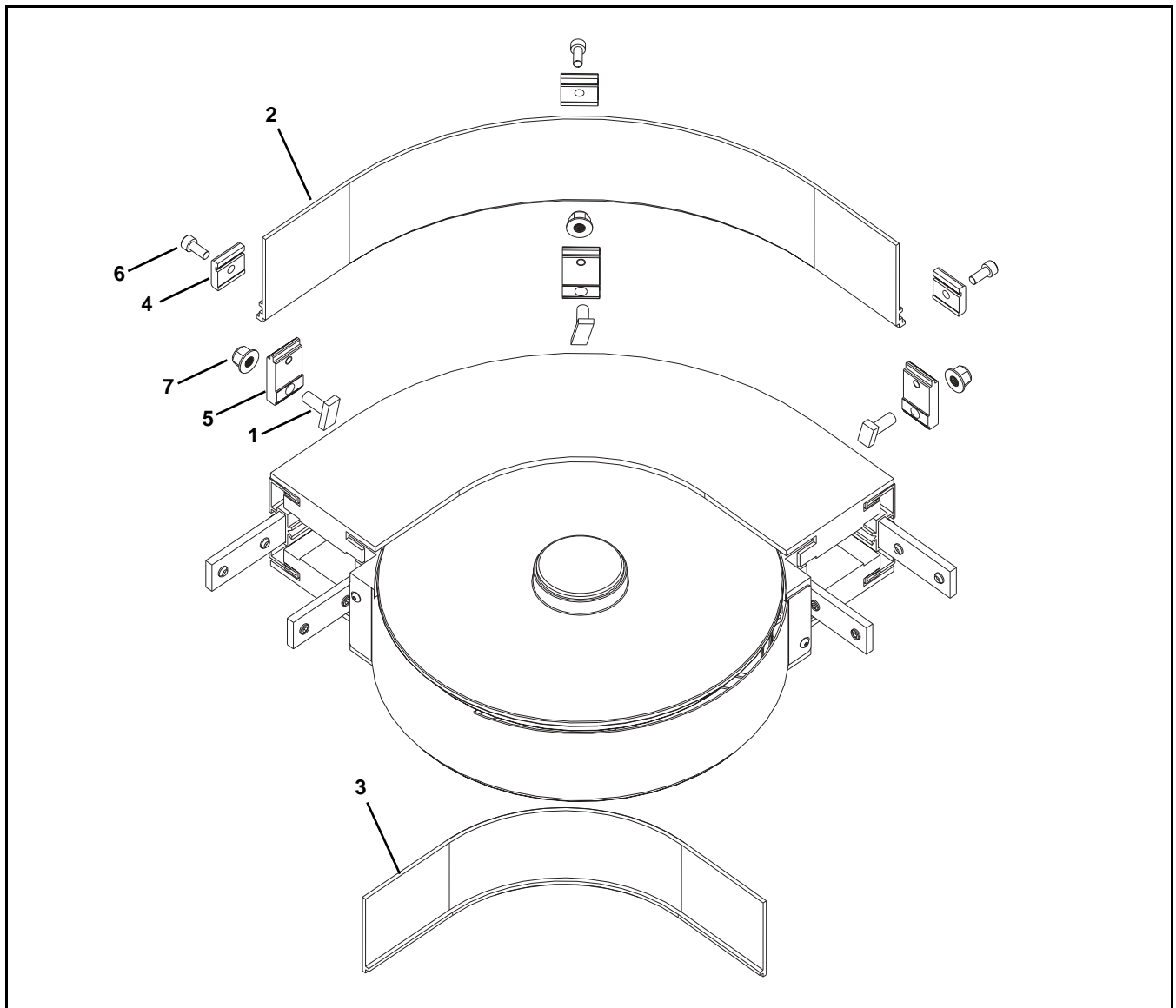
# Service Parts

## #4 & #5 High Sides for Straight Modules



Item	Part Number	Description
1	FATB-20	Stud, M8 x 20 mm (x50)
2	380500-LLLLL	1.5" High Side
	380400-LLLLL	3" High Side
3	204566	Mounting Clip
4	210829	Guide Clip Adapter
	210831	Guide Clip Adapter for Tail Mount Only
	210836	Guide Clip Adapter for Roller Transfer Tail Mount Only
5	920614M	Socket Head Screw, M6-1.00 x 14 mm
6	990812M	Hex Nut, M8-1.25
LLLLL = Part length in inches with two decimal places.		
Length Example: Length = 95.25" LLLLL = 09525		
Service parts can be obtained through your distributor or directly from Dorner Mfg. Corp. (800) 397-8664 or customerservice@dorner.com		

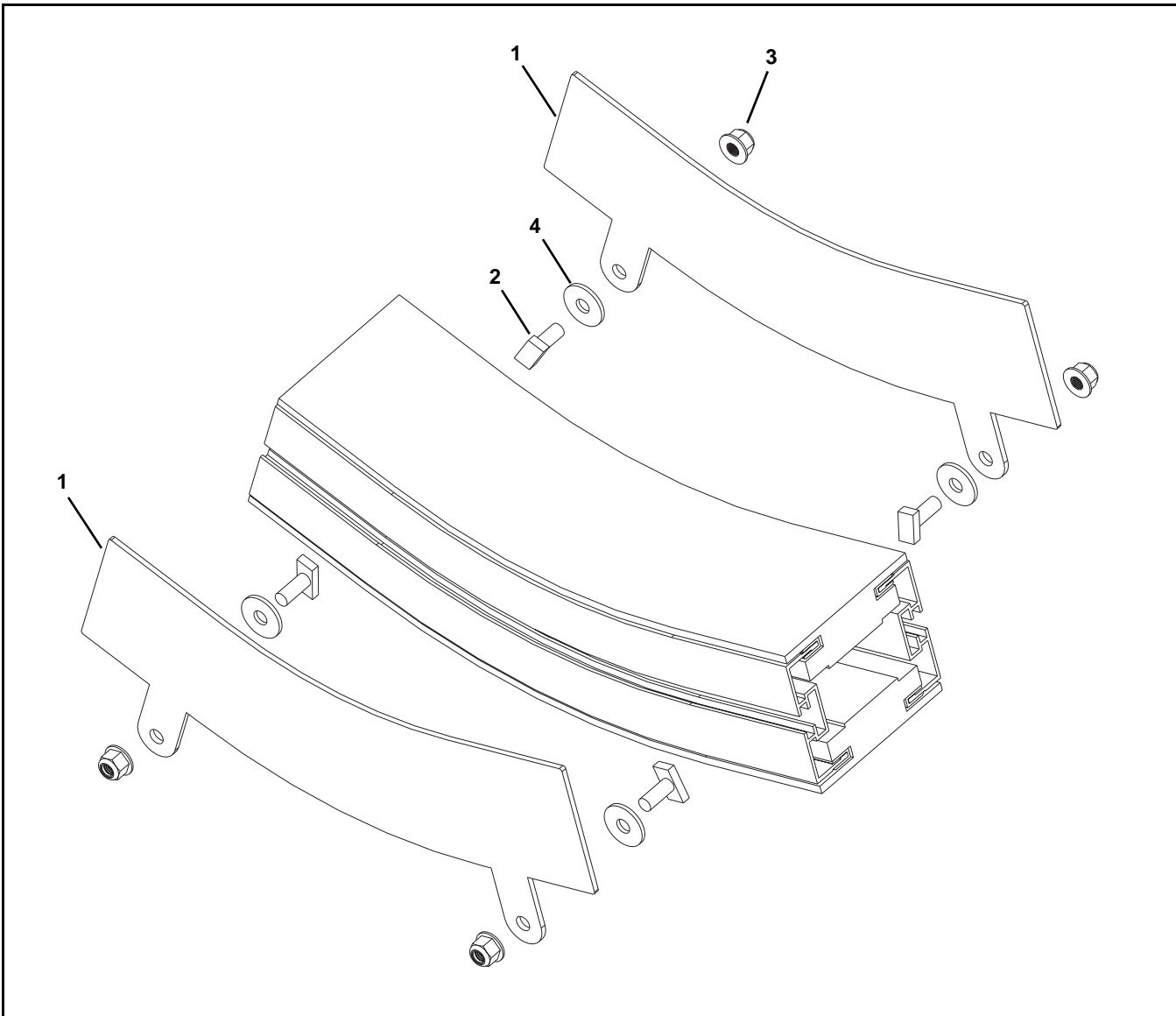
## #4 & #5 High Sides for Curve Modules



Item	Part Number	Description
1	FATB-20	Stud, M8 x 20 mm (x50)
2	204338-260- <u>AAA</u>	1.50" High Side for 700R Plain Bend Curves - Outside Edge
	204340-260- <u>AAA</u>	3" High Side for 700R Plain Bend Curves - Outside Edge
3	204337-260- <u>AAA</u>	1.50" High Side for 700R Plain Bend Curves - Inside Edge
	204339-260- <u>AAA</u>	3" High Side for 700R Plain Bend Curves - Inside Edge
4	204566	Mounting Clip
5	210829	Clip Guide Adapter
6	920614M	Socket Head Screw, M6-1.00 x 14 mm
7	990812M	Hex Nut, M8-1.25
<u>AAA</u> = Angle of curve: 030, 045, 060, 090		
Service parts can be obtained through your distributor or directly from Dorner Mfg. Corp. (800) 397-8664 or customerservice@dorner.com		

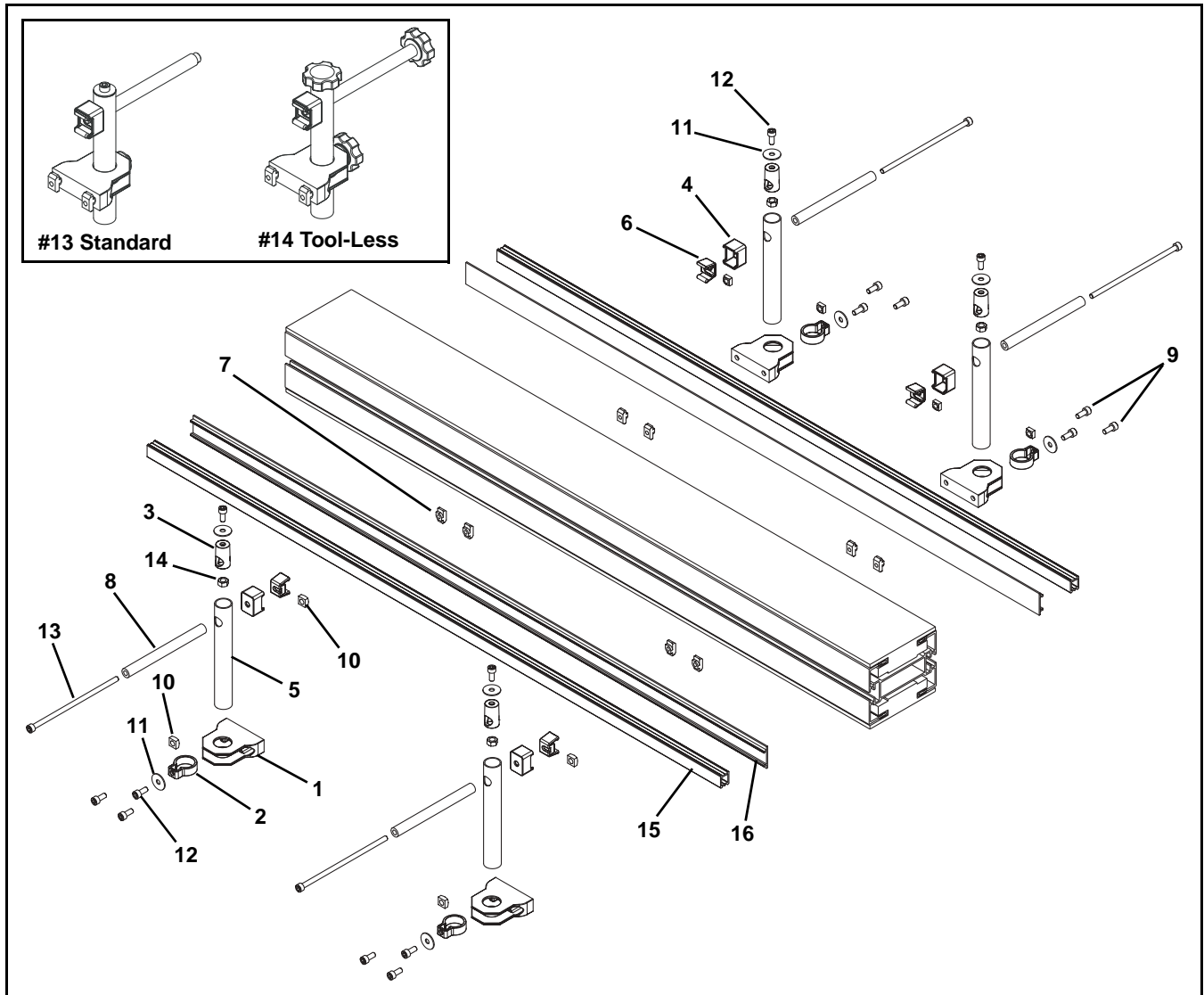
# Service Parts

## #4 & #5 High Sides for Incline/Decline Modules



Item	Part Number	Description
1	204342-AA-260	1.5" Guide Plate for Lower knuckle
	204343-AA-260	1.5" Guide Plate for Upper knuckle
	204144-AA-260	3" Guide Plate for Lower knuckle
	204174-AA-260	3" Guide Plate for Upper Knuckle
2	FATB-20	Stud, M8 x 20 mm (x50)
3	990812M	Hex Nut, M8-1.25
4	204145	Spacer
AA = Angle of bend: 05, 07, 10, 15, 20, 30, 45, 60, 90		
Service parts can be obtained through your distributor or directly from Dorner Mfg. Corp. (800) 397-8664 or customerservice@dorner.com		

## #13 & #14 Heavy Duty Fully Adjustable Guiding



Item	Part Number	Description
1	206380	Base
2	206381	Base Clamp
3	206382	Insert Clamp
4	206383	Guide Ring
5	206385	Tube
6	206397	Clip
7	206685	T-Nut
8	206692	Guide Tube
9	807-2859	Nylon Cap Screw, M6 x 16 mm
10	807-920	Square Nut, M6-1.0
11	911-710	Washer
12	920616M	Socket Head Screw, M6-1.00 x 16 mm
	206698	Knob, 12 mm (Tool-Less)
13	9206150M	Socket Head Screw, M6-1.00 x 150 mm
	206697	Knob, 150 mm (Tool-Less)
14	990601M	Hex Nut

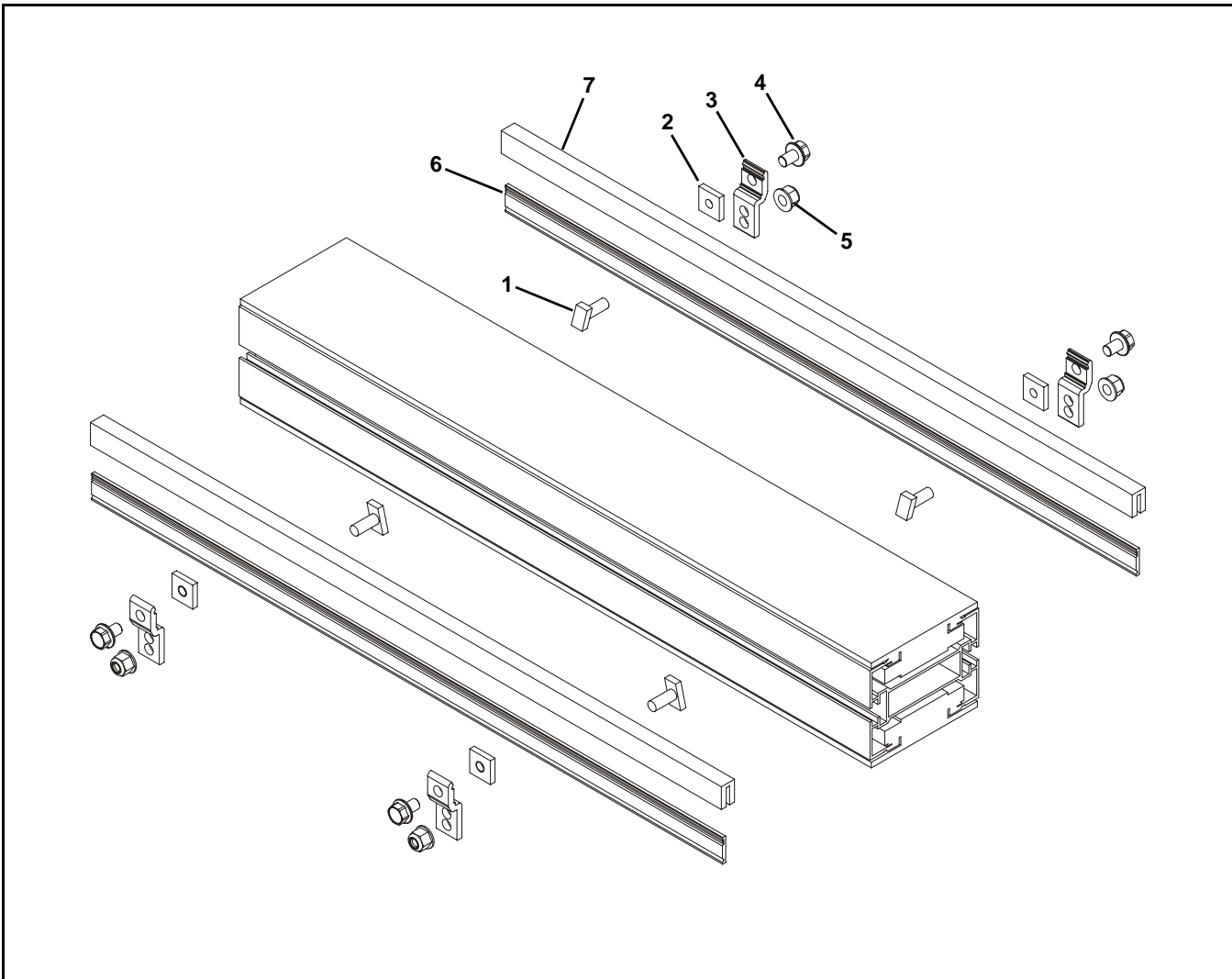
Item	Part Number	Description
15	FGRR-15x20-LLLLL	Guide Rail
	GTB13A04	Guide Rail 4' long
	GTB13A08	Guide Rail 8' long
16	FGRT-3x33	1.3" UHMW Guiding (per foot)
	GTB13B04	1.3" UHMW Guiding 4' long
	GTB13B08	1.3" UHMW Guiding 8' long
	206683	2" UHMW Guiding (per foot)
	GTB13C04	2" UHMW Guiding 4' long
	GTB13C08	2" UHMW Guiding 8' long
17	206686	Adjustable Bracket Assembly (Includes Items 1 through 14)
	206687	Tool-Less Adjustable Bracket Assembly (Includes Items 1 through 14)

LLLLL = part length in inches with 2 decimal places  
 Length Example: Length = 35.25" LLLLL = 03525

Service parts can be obtained through your distributor or directly from Dorner Mfg. Corp. (800) 397-8664 or customerservice@dorner.com

# Service Parts

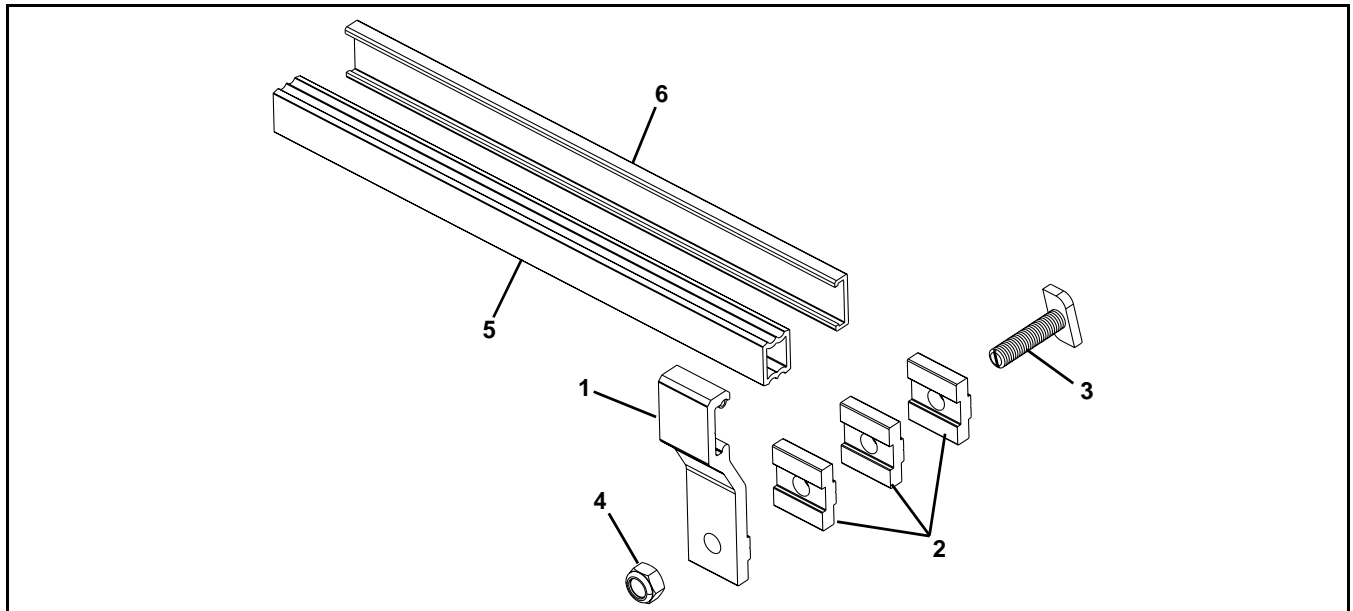
## #17 & #18 - Puck / Pallet Guiding



Item	Part Number	Description
1	FATB-20	Stud, M8 x 20 mm (x50)
2	FASN-M8	Square Nut, M8
3	205129	Clip
4	960882M	Hex Head Flange Screw, M8 x 12 mm
5	990812M	Hex Nut, M8-1.25
6	460055	Guide Rail (per foot)
7	203825	Clip On Slide Rail (per foot)

Service parts can be obtained through your distributor or directly from Dorner Mfg. Corp. (800) 397-8664 or [customerservice@dorner.com](mailto:customerservice@dorner.com)

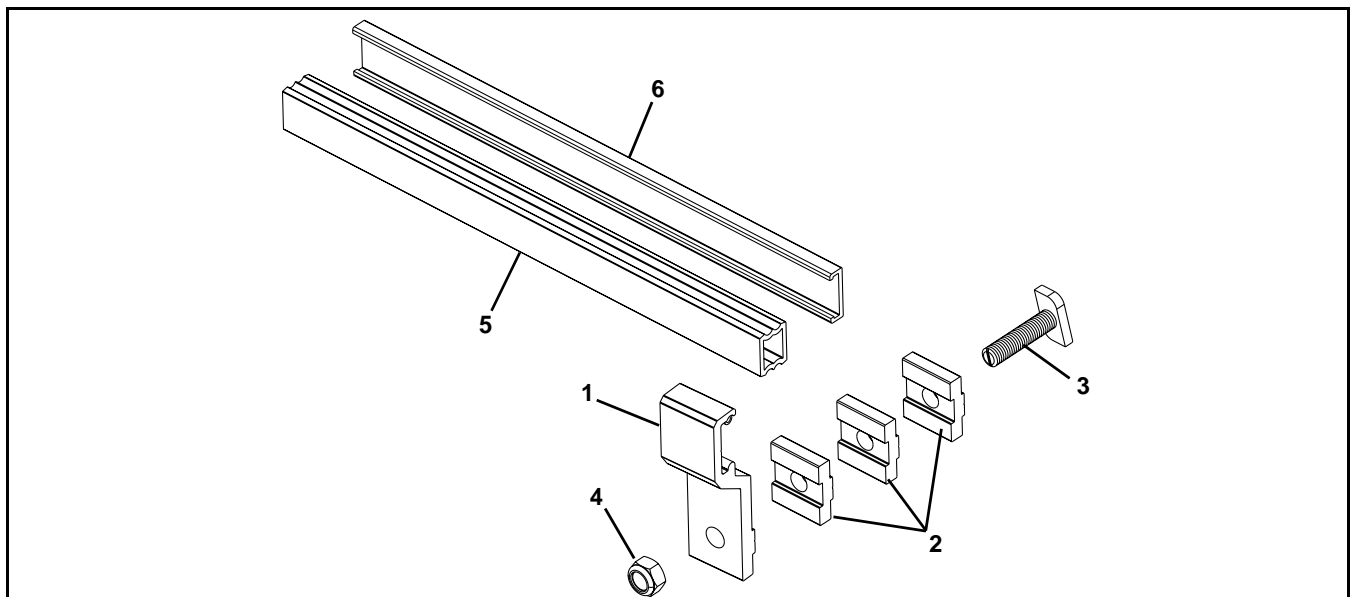
## Type A - Fixed Guiding (16x54)



Item	Part Number	Description
1	FGRB-16x54	Fixed Guide Rail Bracket (x10)
2	FGRD-6	Spacer (x10)
3	FATB-20	T-Bolt, 20 mm, use without spacer (x50)
	FATB-35	T-Bolt, 35 mm (x50)
4	990802M	Hex Nut

Item	Part Number	Description
5	FGRR-15x20	Guide Rail (3 m long)
6	FGRT-3x23	Guiding (3 m long)
Service parts can be obtained through your distributor or directly from Dornier Mfg. Corp. (800) 397-8664 or customerservice@dornier.com		

## Type B - Fixed Guiding (16x42)

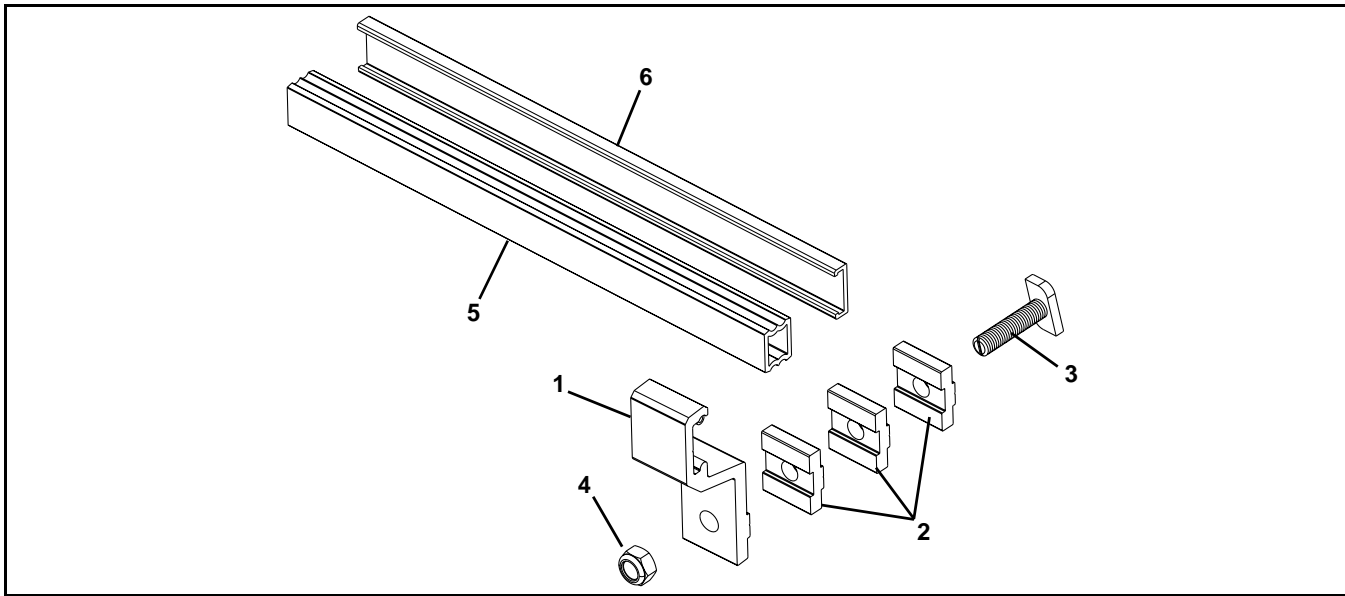


Item	Part Number	Description
1	FGRB-16x42	Fixed Guide Rail Bracket (x10)
2	FGRD-6	Spacer (x10)
3	FATB-20	T-Bolt, 20 mm, use without spacer (x50)
	FATB-35	T-Bolt, 35 mm (x50)
4	990802M	Hex Nut
5	FGRR-15x20	Guide Rail (3 m long)

Item	Part Number	Description
6	FGRT-3x23	Guiding (3 m long)
Service parts can be obtained through your distributor or directly from Dornier Mfg. Corp. (800) 397-8664 or customerservice@dornier.com		

# Service Parts

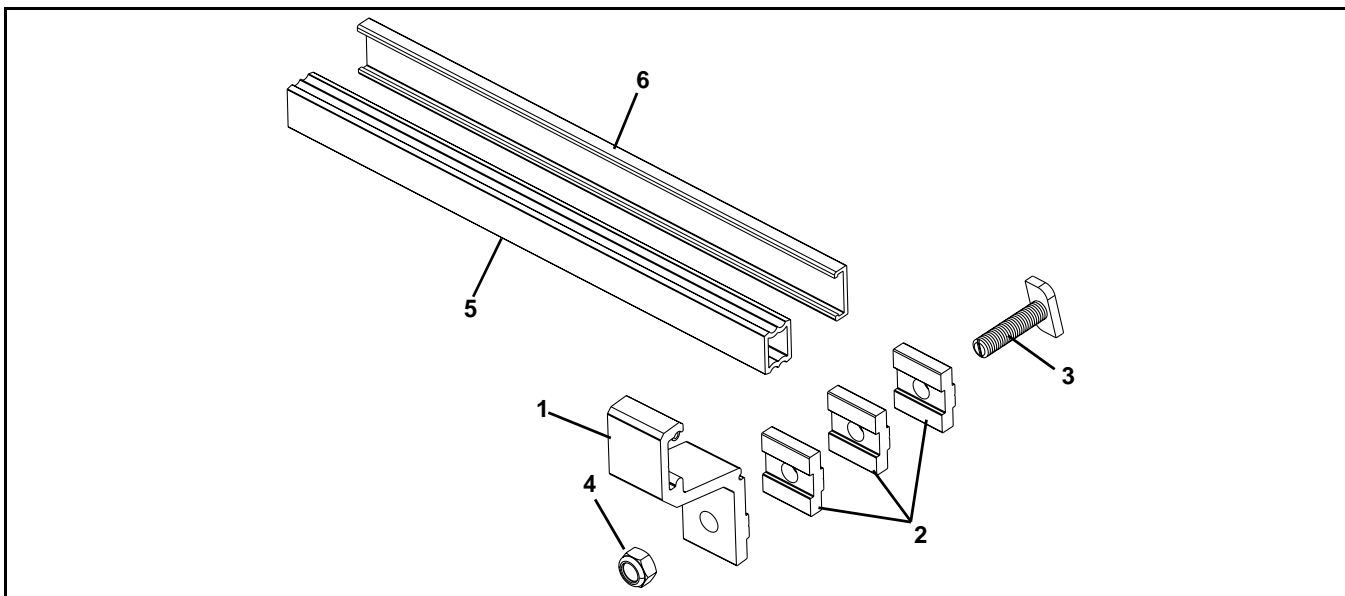
## Type C - Fixed Guiding (28x42)



Item	Part Number	Description
1	FGRB-28x42	Fixed Guide Rail Bracket (x10)
2	FGRD-6	Spacer (x10)
3	FATB-20	T-Bolt, 20 mm, use without spacer (x50)
	FATB-35	T-Bolt, 35 mm (x50)
4	990802M	Hex Nut

Item	Part Number	Description
5	FGRR-15x20	Guide Rail (3 m long)
6	FGRT-3x23	Guiding (3 m long)
Service parts can be obtained through your distributor or directly from Dornier Mfg. Corp. (800) 397-8664 or customerservice@dornier.com		

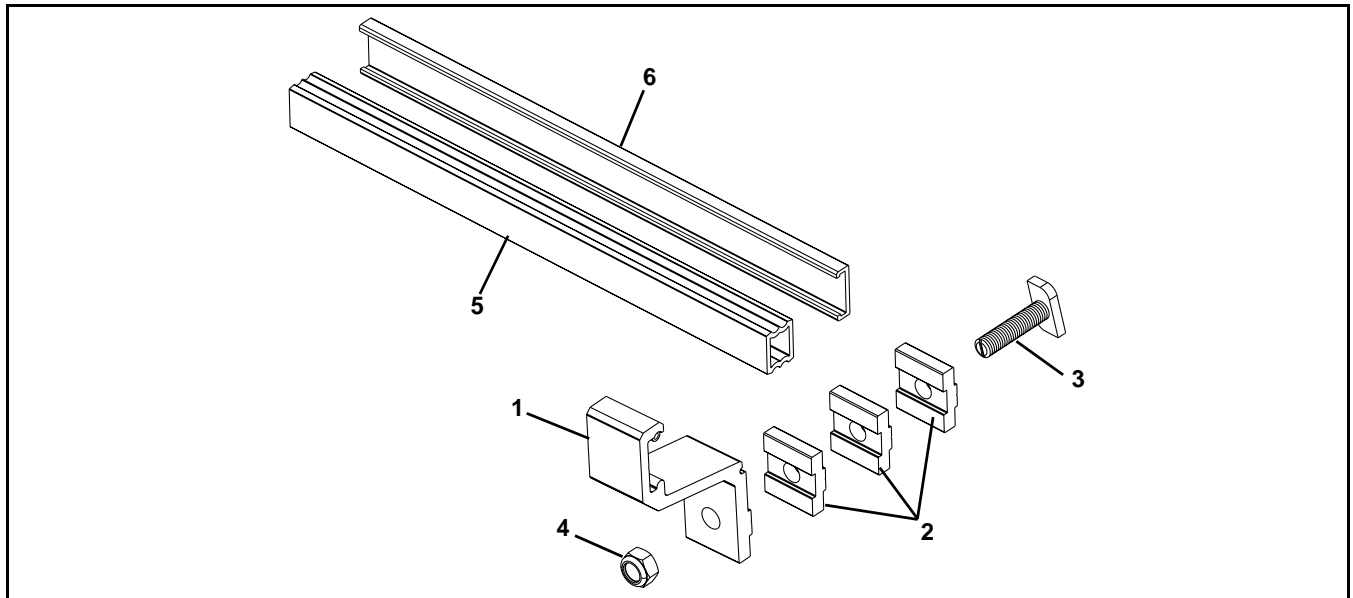
## Type D - Fixed Guiding (40x42)



Item	Part Number	Description
1	FGRB-40x42	Fixed Guide Rail Bracket (x10)
2	FGRD-6	Spacer (x10)
3	FATB-20	T-Bolt, 20 mm, use without spacer (x50)
	FATB-35	T-Bolt, 35 mm (x50)
4	990802M	Hex Nut
5	FGRR-15x20	Guide Rail (3 m long)

Item	Part Number	Description
6	FGRT-3x23	Guiding (3 m long)
Service parts can be obtained through your distributor or directly from Dornier Mfg. Corp. (800) 397-8664 or customerservice@dornier.com		

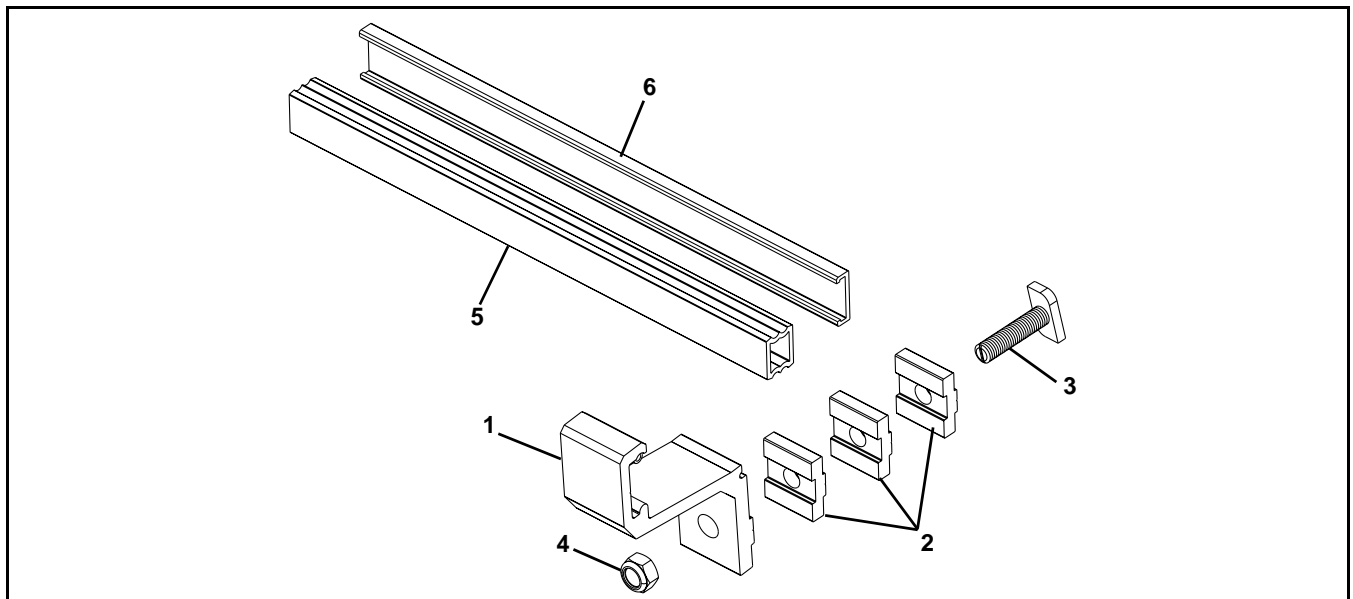
## Type E - Fixed Guiding (49x42)



Item	Part Number	Description
1	FGRB-49x42	Fixed Guide Rail Bracket (x10)
2	FGRD-6	Spacer (x10)
3	FATB-20	T-Bolt, 20 mm, use without spacer (x50)
	FATB-35	T-Bolt, 35 mm (x50)
4	990802M	Hex Nut

Item	Part Number	Description
5	FGRR-15x20	Guide Rail (3 m long)
6	FGRT-3x23	Guiding (3 m long)
Service parts can be obtained through your distributor or directly from Dorner Mfg. Corp. (800) 397-8664 or customerservice@dorner.com		

## Type F - Fixed Guiding (53x42)

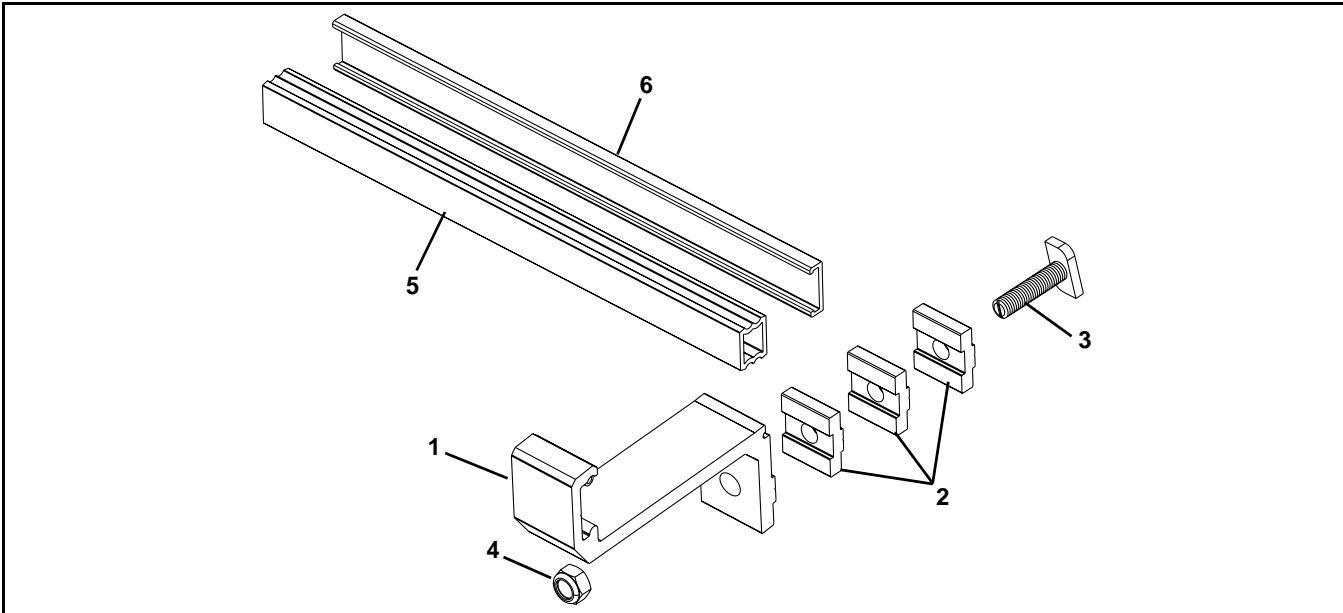


Item	Part Number	Description
1	FGRB-53x42	Fixed Guide Rail Bracket (x10)
2	FGRD-6	Spacer (x10)
3	FATB-20	T-Bolt, 20 mm, use without spacer (x50)
	FATB-35	T-Bolt, 35 mm (x50)
4	990802M	Hex Nut

Item	Part Number	Description
5	FGRR-15x20	Guide Rail (3 m long)
6	FGRT-3x23	Guiding (3 m long)
Service parts can be obtained through your distributor or directly from Dorner Mfg. Corp. (800) 397-8664 or customerservice@dorner.com		

# Service Parts

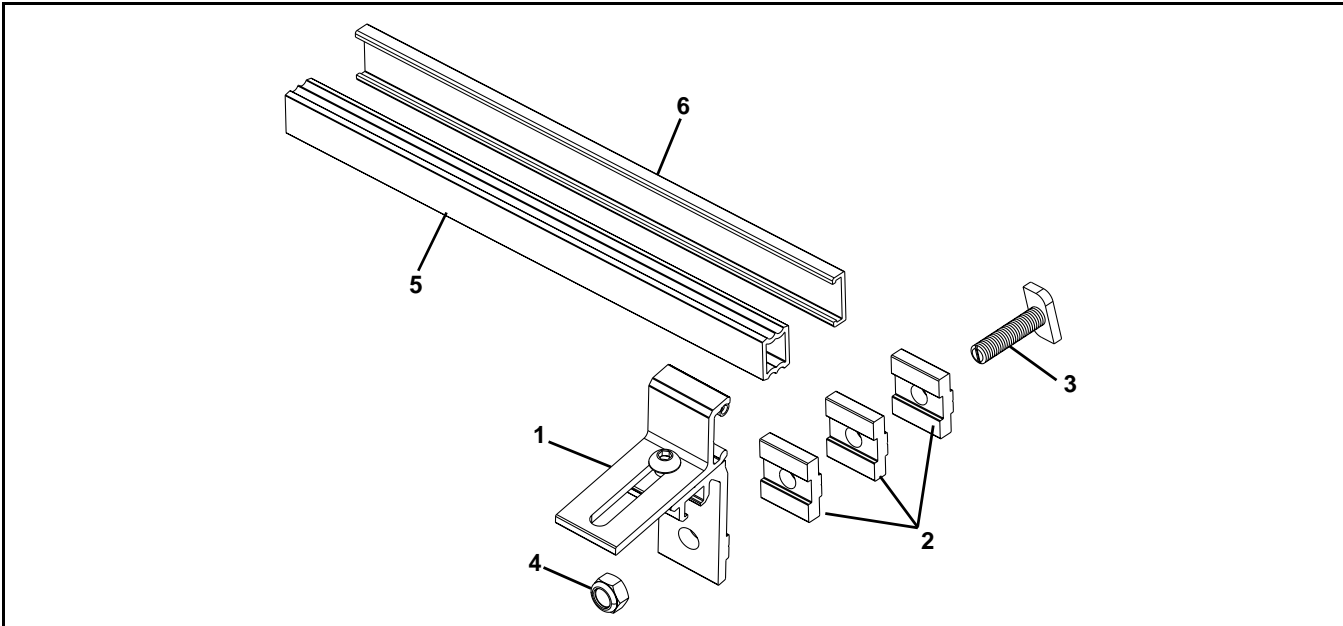
## Type G - Fixed Guiding (90x42)



Item	Part Number	Description
1	FGRB-90x42	Fixed Guide Rail Bracket (x10)
2	FGRD-6	Spacer (x10)
3	FATB-20	T-Bolt, 20 mm, use without spacer (x50)
	FATB-35	T-Bolt, 35 mm (x50)
4	990802M	Hex Nut

Item	Part Number	Description
5	FGRR-15x20	Guide Rail (3 m long)
6	FGRT-3x23	Guiding (3 m long)
Service parts can be obtained through your distributor or directly from Dorner Mfg. Corp. (800) 397-8664 or customerservice@dorner.com		

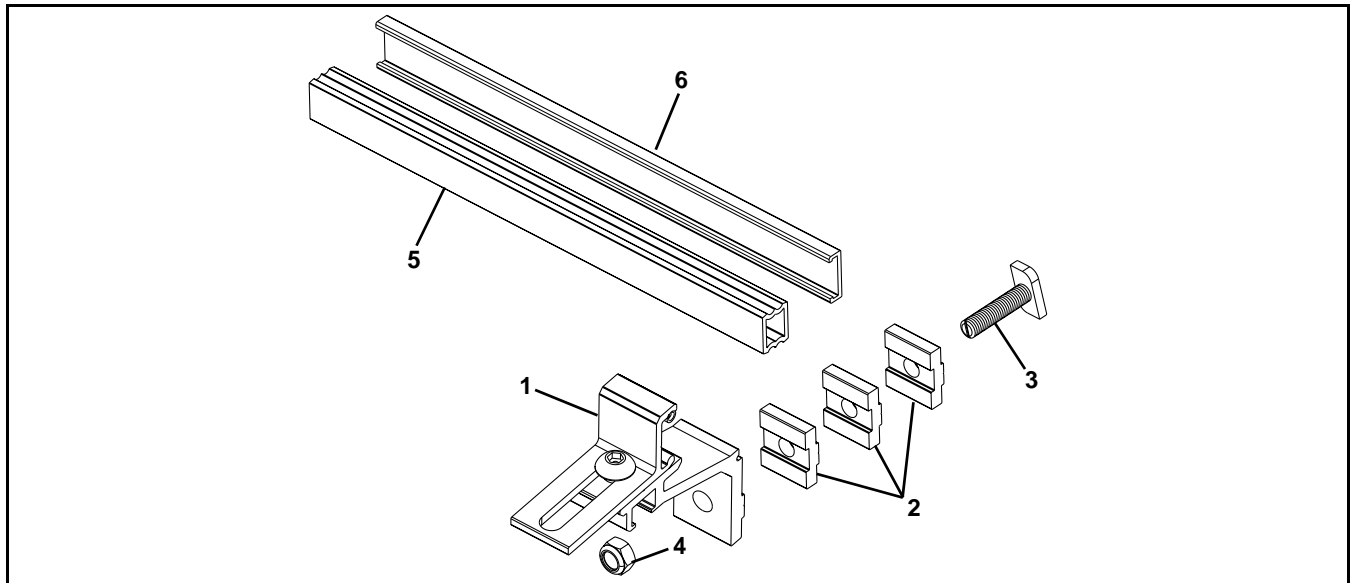
## Type H - Adjustable Width Guiding (8x39x45)



Item	Part Number	Description
1	FGRA-8x39x45	Fixed Guide Rail Bracket (x10)
2	FGRD-6	Spacer (x10)
3	FATB-20	T-Bolt, 20 mm, use without spacer (x50)
	FATB-35	T-Bolt, 35 mm (x50)
4	990802M	Hex Nut

Item	Part Number	Description
5	FGRR-15x20	Guide Rail (3 m long)
6	FGRT-3x23	Guiding (3 m long)
Service parts can be obtained through your distributor or directly from Dorner Mfg. Corp. (800) 397-8664 or customerservice@dorner.com		

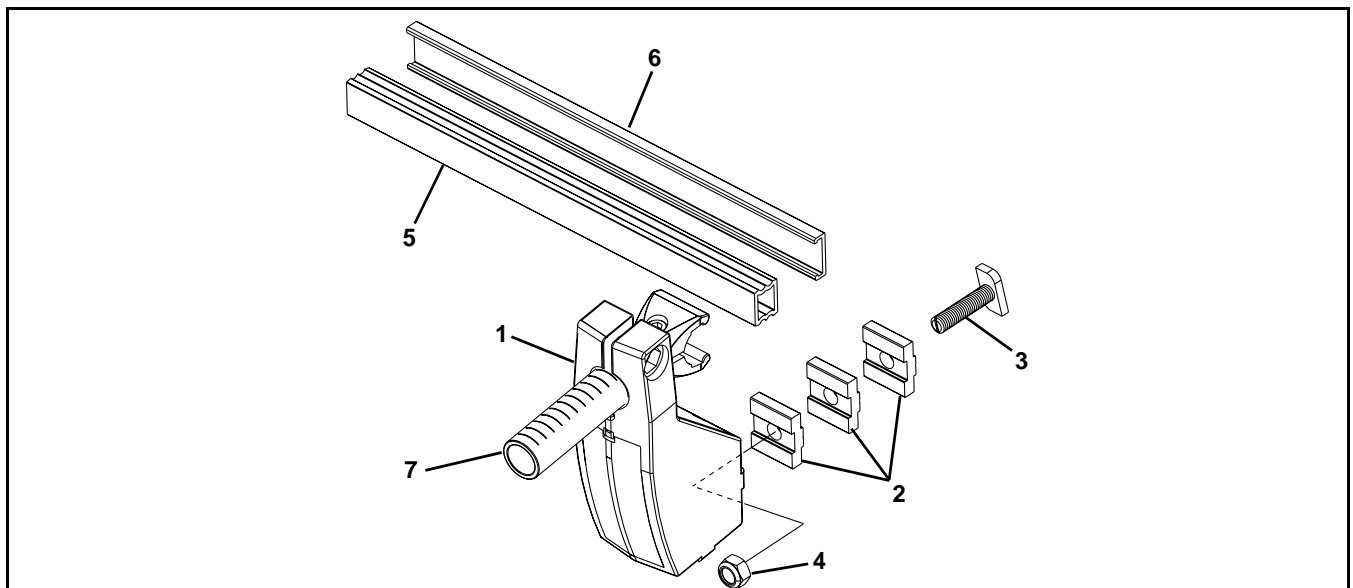
## Type J - Adjustable Width Guiding (26x39x45)



Item	Part Number	Description
1	FGRA-26x39x45	Fixed Guide Rail Bracket (x10)
2	FGRD-6	Spacer (x10)
3	FATB-20	T-Bolt, 20 mm, use without spacer (x50)
	FATB-35	T-Bolt, 35 mm (x50)
4	990802M	Hex Nut

Item	Part Number	Description
5	FGRR-15x20	Guide Rail (3 m long)
6	FGRT-3x23	Guiding (3 m long)
Service parts can be obtained through your distributor or directly from Dorner Mfg. Corp. (800) 397-8664 or customerservice@dorner.com		

## Type K - Adjustable Width Guiding (40x18)

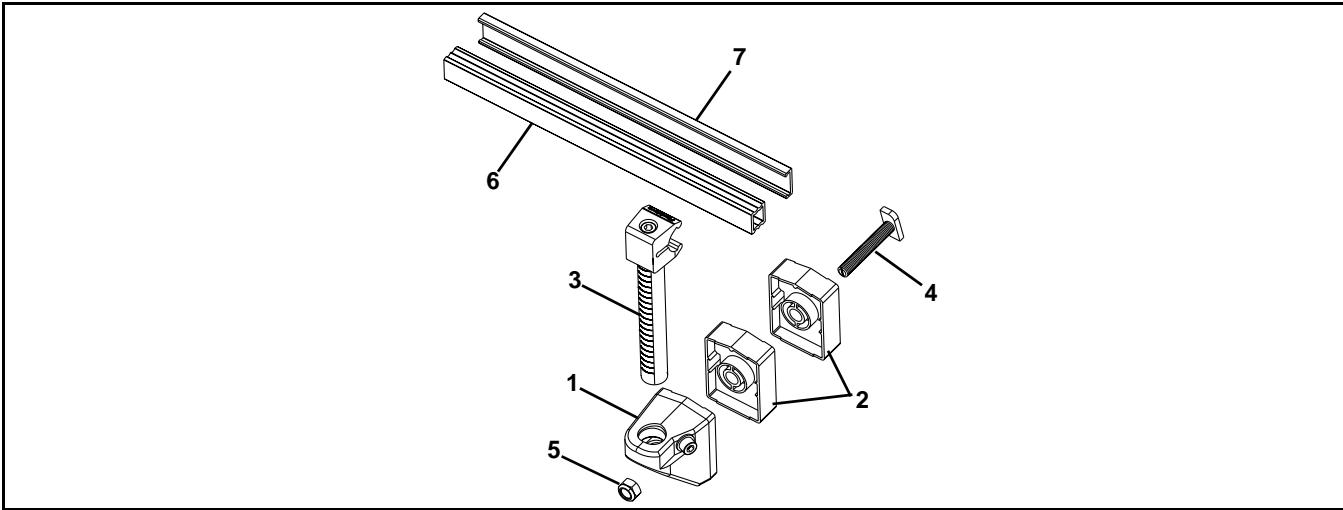


Item	Part Number	Description
1	FGRA-40x18	Fixed Guide Rail Bracket (x10)
2	FGRD-6	Spacer (x10)
3	FATB-20	T-Bolt, 20 mm, use without spacer (x50)
	FATB-35	T-Bolt, 35 mm (x50)
4	990802M	Hex Nut
5	FGRR-15x20	Guide Rail (3 m long)
6	FGRT-3x23	Guiding (3 m long)

Item	Part Number	Description
7	FGRK-18x80A	Guide Rail Support (x10)
Service parts can be obtained through your distributor or directly from Dorner Mfg. Corp. (800) 397-8664 or customerservice@dorner.com		

# Service Parts

## Type L - Adjustable Height Guiding (18x110)

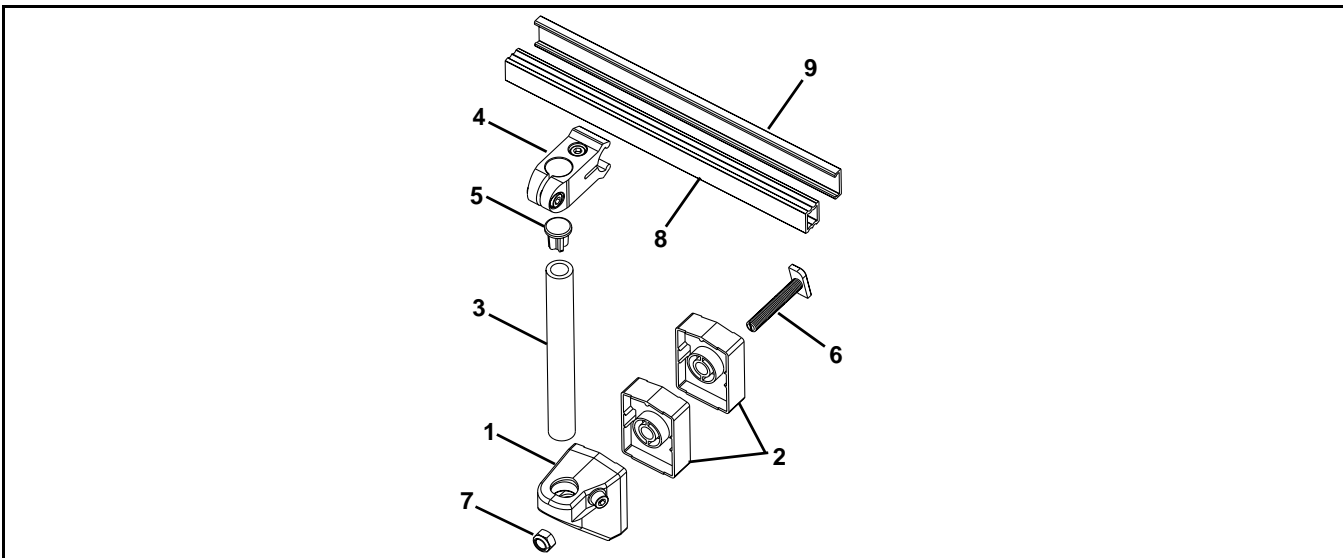


Item	Part Number	Description
1	FGRF-42x18V	Guide Rail Bracket (x10)
2	FGRD-18A	Spacer (x10)
3	FGRL-18x110C	Guide Rail Support (x10)
4	FATB-20	T-Bolt, 20 mm, use without spacer (x50)
	FATB-35	T-Bolt, 35 mm, use with 1 spacer (x50)
	FATB-53	T-Bolt, 53 mm, use with 2 spacers (x50)
5	990802M	Hex Nut

Item	Part Number	Description
6	FGRR-15x20	Guide Rail (3 m long)
7	FGRT-3x23	Guiding (3 m long)

Service parts can be obtained through your distributor or directly from Dorner Mfg. Corp. (800) 397-8664 or customerservice@dorner.com

## Type M - Adjustable Height Guiding (18x150)

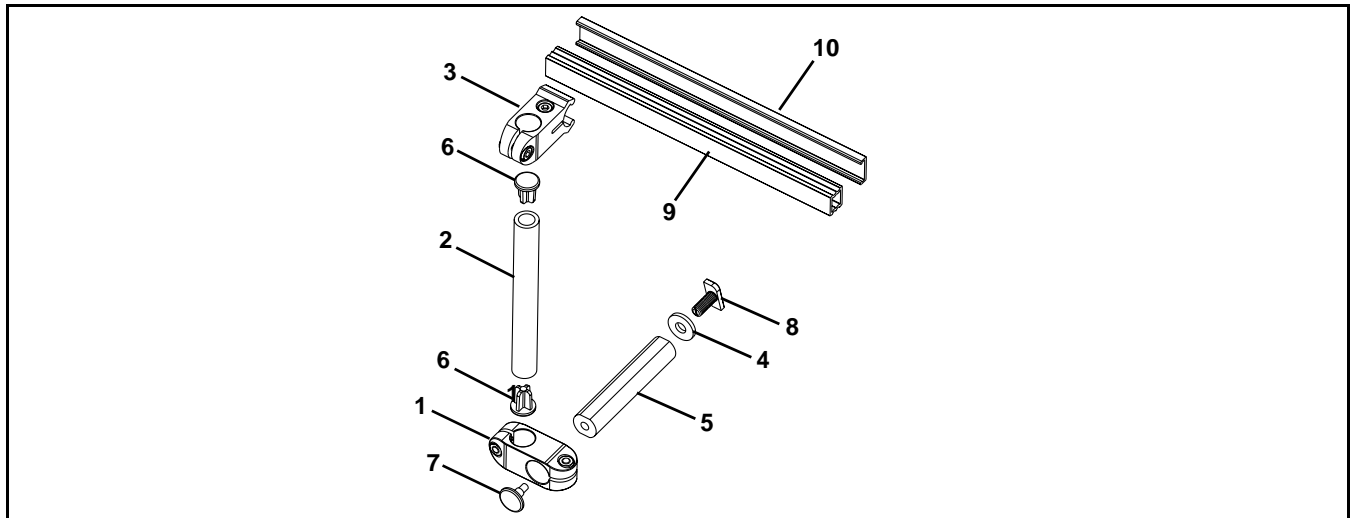


Item	Part Number	Description
1	FGRF-42x18V	Guide Rail Bracket (x10)
2	FGRD-18A	Spacer (x10)
3	FGDT-150	Tube (x10)
4	FGRS-18	Guide Rail Support (x10)
5	FGEC-18	Cap (x10)
6	FATB-20	T-Bolt, 20 mm, use without spacer (x50)
	FATB-35	T-Bolt, 35 mm, use with 1 spacer (x50)
	FATB-53	T-Bolt, 53 mm, use with 2 spacers (x50)

Item	Part Number	Description
7	990802M	Hex Nut
8	FGRR-15x20	Guide Rail (3 m long)
9	FGRT-3x23	Guiding (3 m long)

Service parts can be obtained through your distributor or directly from Dorner Mfg. Corp. (800) 397-8664 or customerservice@dorner.com

## Type N - Fully Adjustable Guiding

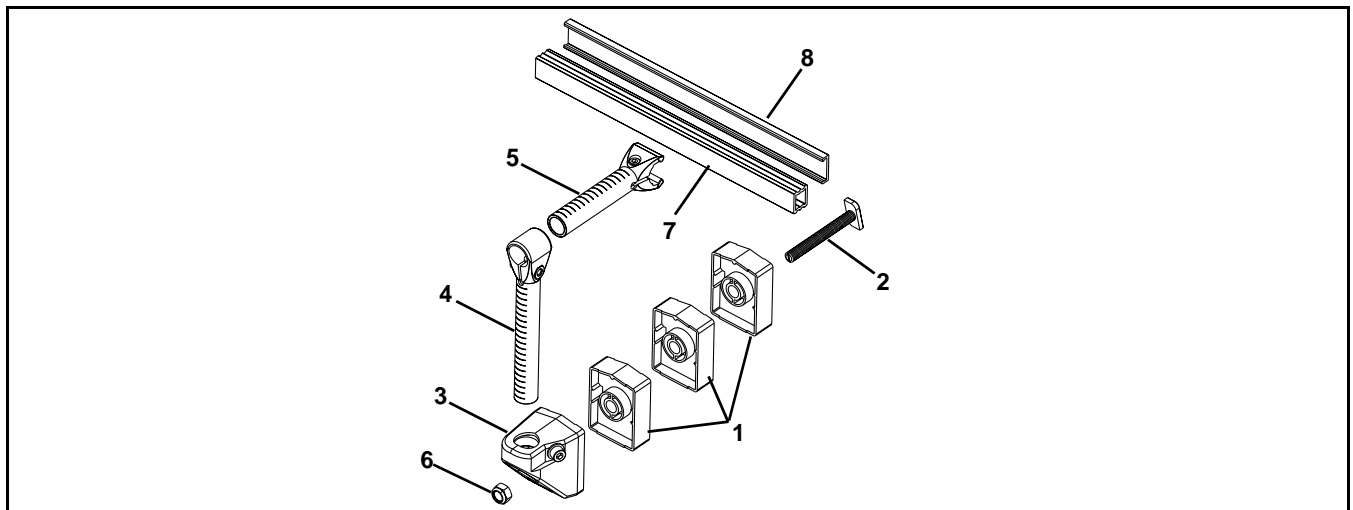


Item	Part Number	Description
1	FGRB-18x20	Guide Rail Bracket (x10)
2	FGDT-70	Tube, 70 mm (x10)
	FGDT-100	Tube, 100 mm (x10)
	FGDT-150	Tube, 150 mm (x10)
3	FGRS-18	Guide Rail Support (x10)
4	FGSP-DT	Tube Spacer (x10)
5	FGGR-18x100	Guide Rail Tube, 100 mm (x10)
	FGGR-18x150	Guide Rail Tube, 150 mm (x10)
	FGGR-18x200	Guide Rail Tube, 200 mm (x10)

Item	Part Number	Description
6	FGEC-18	Cap (x10)
7	FGEC-20	Cap (x10)
8	FATB-20	T-Bolt, 20 mm (x50)
9	FGRR-15x20	Guide Rail (3 m long)
10	FGRT-3x23	Guiding (3 m long)

Service parts can be obtained through your distributor or directly from Dorner Mfg. Corp. (800) 397-8664 or customerservice@dorner.com

## Type P - Fully Adjustable Guiding



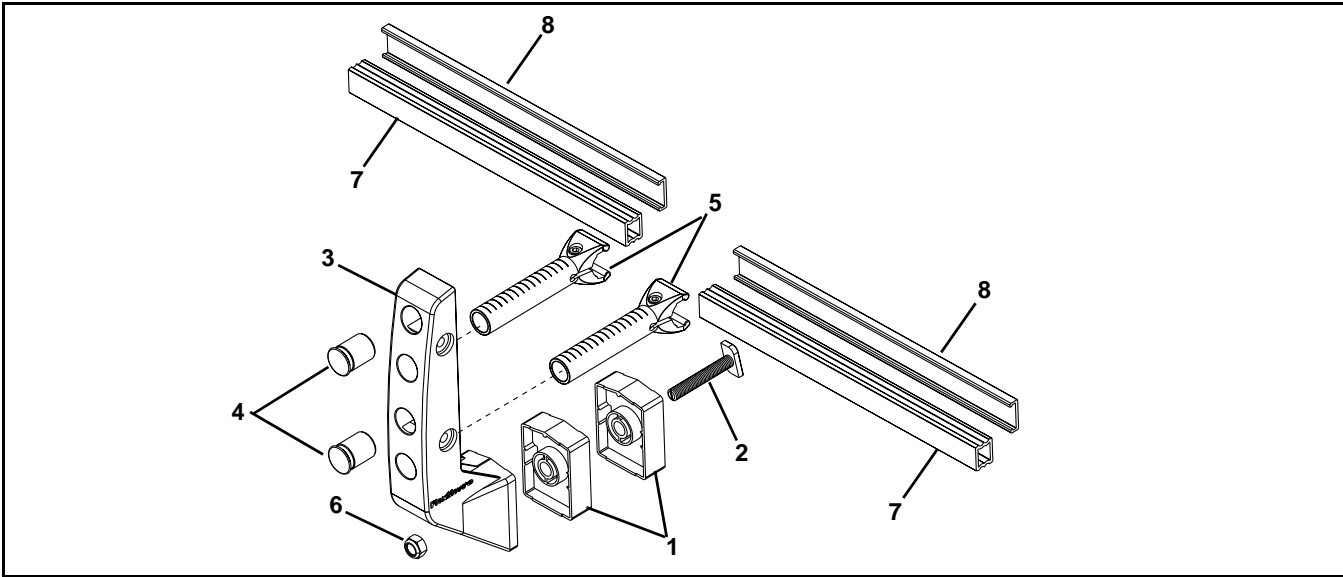
Item	Part Number	Description
1	FGRD-18A	Spacer (x10)
2	FATB-20	T-Bolt, 20 mm, use without spacer (x50)
	FATB-35	T-Bolt, 35 mm, use with 1 spacer (x50)
	FATB-53	T-Bolt, 53 mm, use with 2 spacers (x50)
	FATB-71	T-Bolt, 71 mm, use with 3 spacers (x50)
3	FGRF-42x18V	Guide Rail Bracket (x10)
4	FGRL-18x160CA	Vertical Support (x10)

Item	Part Number	Description
5	FGRK-18x80A	Guide Rail Support (x10)
6	990802M	Hex Nut
7	FGRR-15x20	Guide Rail (3 m long)
8	FGRT-3x23	Guiding (3 m long)

Service parts can be obtained through your distributor or directly from Dorner Mfg. Corp. (800) 397-8664 or customerservice@dorner.com

# Service Parts

## Type Q - Dual Rail Guiding

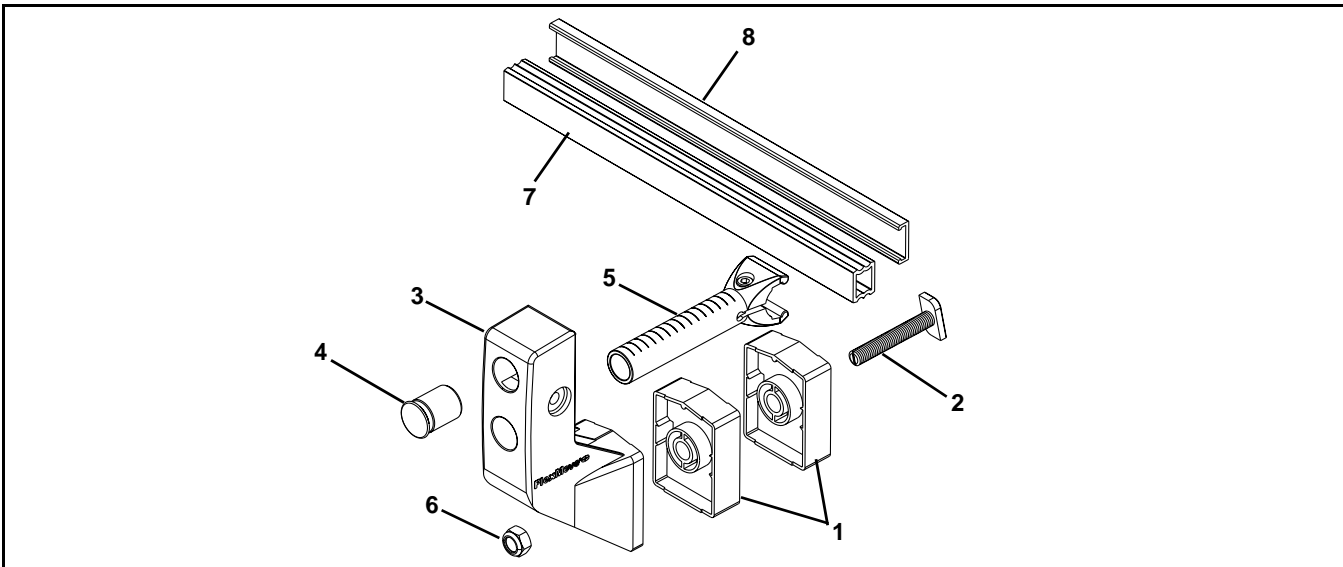


Item	Part Number	Description
1	FGRD-18A	Spacer (x10)
2	FATB-20	T-Bolt, 20 mm, use without spacer (x50)
	FATB-35	T-Bolt, 35 mm, use with 1 spacer (x50)
	FATB-53	T-Bolt, 53 mm, use with 2 spacers (x50)
3	FGRF-A110	Guide Rail Bracket (x10)
4	FGRF-DP	Plug (x10)

Item	Part Number	Description
5	FGRK-18x80A	Guide Rail Support (x10)
6	990802M	Hex Nut
7	FGRR-15x20	Guide Rail (3 m long)
8	FGRT-3x23	Guiding (3 m long)

Service parts can be obtained through your distributor or directly from Dorner Mfg. Corp. (800) 397-8664 or customerservice@dorner.com

## Type R - Dual Rail Guiding

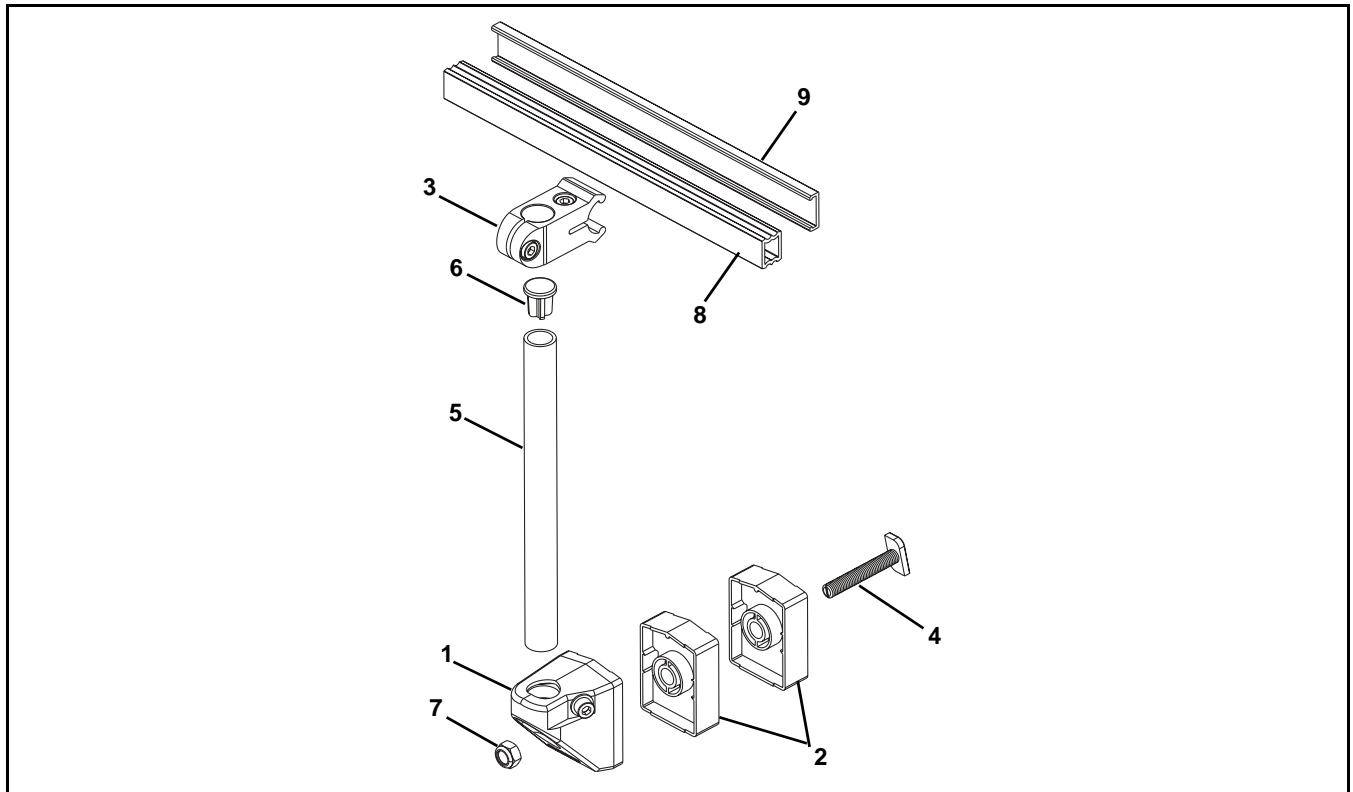


Item	Part Number	Description
1	FGRD-18A	Spacer (x10)
2	FATB-20	T-Bolt, 20 mm, use without spacer (x50)
	FATB-35	T-Bolt, 35 mm, use with 1 spacer (x50)
	FATB-53	T-Bolt, 53 mm, use with 2 spacers (x50)
3	FGRF-A35	Guide Rail Bracket (x10)
4	FGRF-DP	Plug (x10)
5	FGRK-18x80A	Guide Rail Support (x10)
6	990802M	Hex Nut

Item	Part Number	Description
7	FGRR-15x20	Guide Rail (3 m long)
8	FGRT-3x23	Guiding (3 m long)

Service parts can be obtained through your distributor or directly from Dorner Mfg. Corp. (800) 397-8664 or customerservice@dorner.com

## Type S - Adjustable Height Guiding

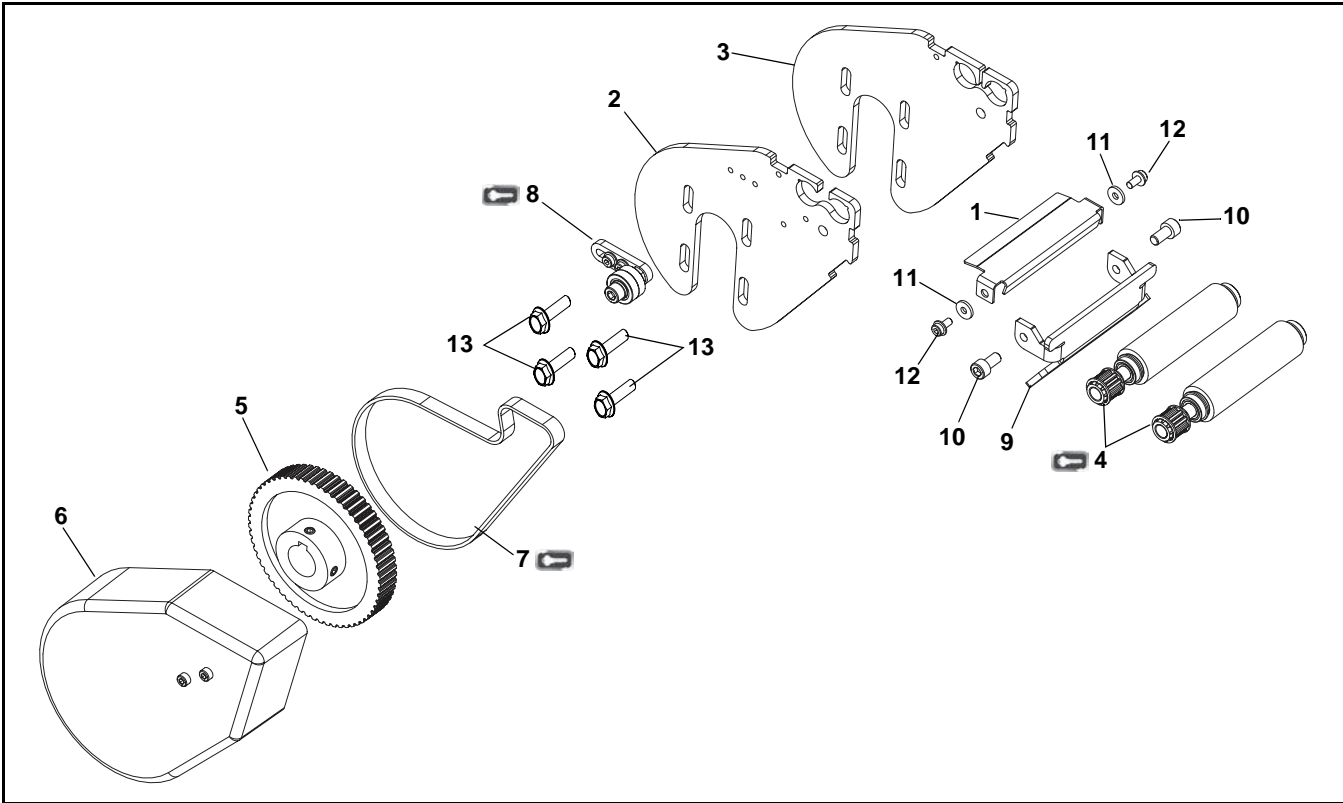


Item	Part Number	Description
1	FGRF-42x18V	Guide Rail Bracket (x10)
2	FGRD-18A	Spacer (x10)
3	FGRS-18	Guide Rail Support (x10)
4	FATB-20	T-Bolt, 20 mm, use without spacer (x50)
	FATB-35	T-Bolt, 35 mm, use with 1 spacer (x50)
	FATB-53	T-Bolt, 53 mm, use with 2 spacers (x50)
5	FGDT-200	Tube (x10)
6	FGEC-18	Cap (x10)
7	990802M	Hex Nut
8	FGRR-15x20	Guide Rail (3 m long)
9	FGRT-3x23	Guiding (3 m long)

Service parts can be obtained through your distributor or directly from Dorner Mfg. Corp. (800) 397-8664 or [customerservice@dorner.com](mailto:customerservice@dorner.com)

# Service Parts

## Driven Bridge

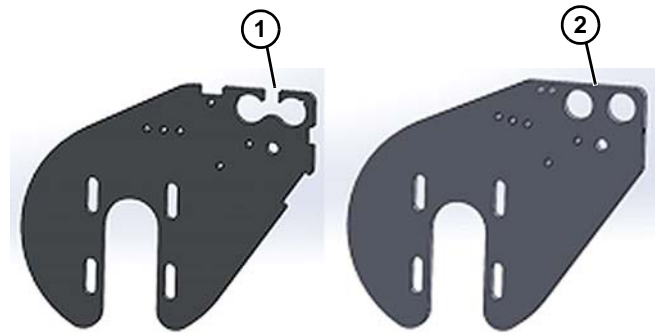


Item	Part Number	Description
1	208095-260	Pinch Plate, USA/Latin America
	CP-A2234	Pinch Plate, Europe/Asia
2	208085-C	Cover Side Plate, USA/Latin America
	CP-A2189	Cover Side Plate, Europe/Asia
3	208085-B	Drive Side Plate, USA/Latin America
	CP-A2189	Drive Side Plate, Europe/Asia
4	208083-260	Spindle Assembly
5	208087	Pulley, USA/Latin America
	ATP60XL037-B-N15	Pulley, Europe/Asia
6	CP-A2200	Cover Assembly
7	814-494	Timing Belt
8	208091	Tensioner Assembly
9	208093-260	End Plate, USA/Latin America
	CP-A2235	End Plate, Europe/Asia
10	920612M	Socket Head Screw, M6-1.00 x 12 mm
11	911-507	Washer
12	920481M	Flange Socket Screw, M4-.70 x 8 mm
13	960687M	Flange Head Cap Screw, M6-1.00 x 35 mm

Service parts can be obtained through your distributor or directly from Dorner Mfg. Corp. (800) 397-8664 or [customerservice@dorner.com](mailto:customerservice@dorner.com)

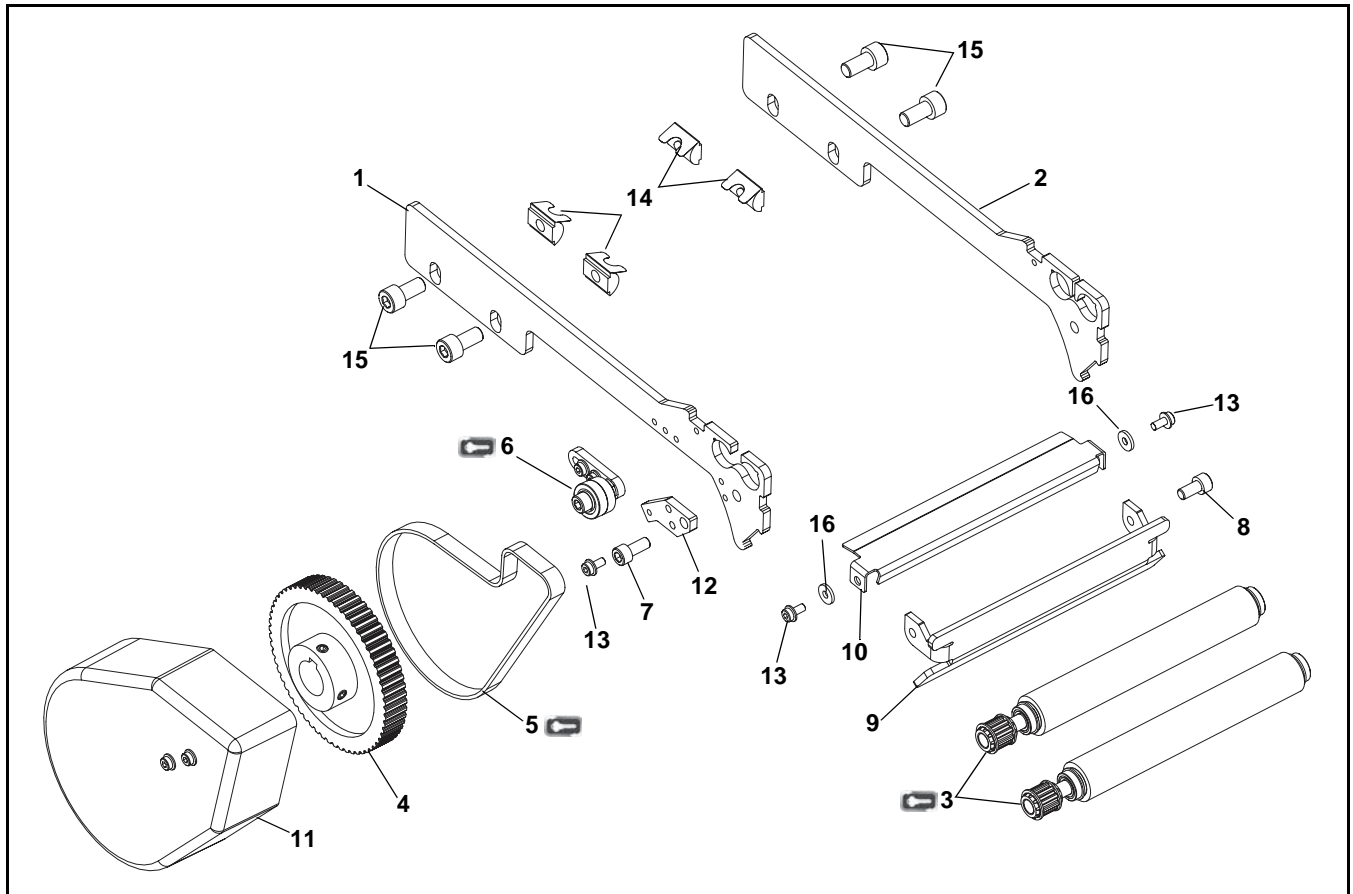
To verify the difference between Dorner USA/ Latin America assemblies and Dorner Europe/ Asia assemblies, check parts #2 and #3:

- If there is a gap (See **Figure 169 item 1**) this is a Dorner USA/Latin America assembly.
- If no gap (See **Figure 169 item 2**) is shown this is a Dorner Europe/Asia assembly.



**Figure 169**

## Suspended Drive Driven Bridge



Item	Part Number	Description
1	208099-C	Cover Side Plate, USA/Latin America
	CP-A2215	Cover Side Plate, Europe/Asia
2	208099-B	Driver Side Plate, USA/Latin America
	CP-A2215	Driver Side Plate, Europe/Asia
3	208083-260	Spindle Assembly
4	208087	Pulley, USA/Latin America
	ATP60XL037-B-N15	Pulley, Europe/Asia
5	814-494	Timing Belt
6	208091	Tensioner Assembly
7	920614M	Socket Head Screw, M6-1.00 x 14 mm
8	920612M	Socket Head Screw, M6-1.00 x 12 mm
9	208093-260	End Plate, USA/Latin America
	CP-A2235	End Plate, Europe/Asia
10	208095-260	Pinch Guard Plate, USA/Latin America
	CP-A2234	Pinch Guard Plate, Europe/Asia
11	CP-A2355	Cover Assembly
12	208126	Cover Mount Block, USA/Latin America
	CP-A2217	Cover Mount Block, Europe/Asia
13	920481M	Flange Socket Screw, M4-.70 x 8 mm
14	FASL-M8	Spring Nut
15	920816M	Socket Head Screw, M8-1.25 x 16 mm
16	911-507	Washer

Service parts can be obtained through your distributor or directly from Dorner Mfg. Corp. (800) 397-8664 or [customerservice@dorner.com](mailto:customerservice@dorner.com)

To verify the difference between Dorner USA/ Latin America assemblies and Dorner Europe/ Asia assemblies, check parts #1 and #2:

- If there is a gap (See Figure 170 item 1) this is a Dorner USA/Latin America assembly.
- If no gap (See Figure 170 item 2) is shown this is a Dorner Europe/Asia assembly.

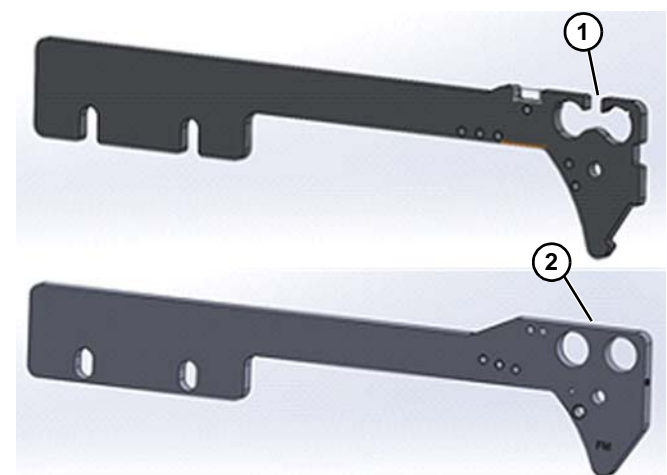
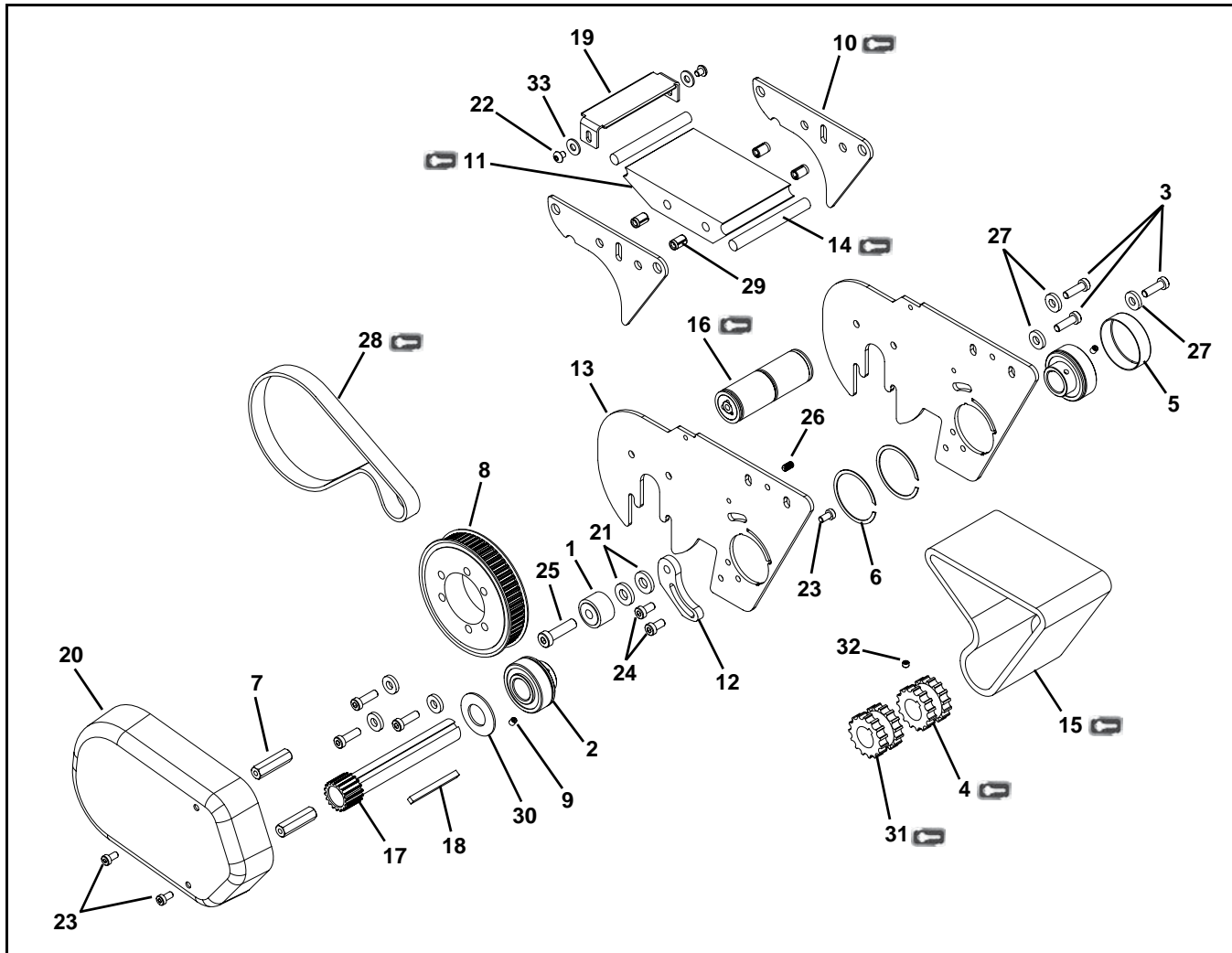


Figure 170

# Service Parts

## Power Transfer

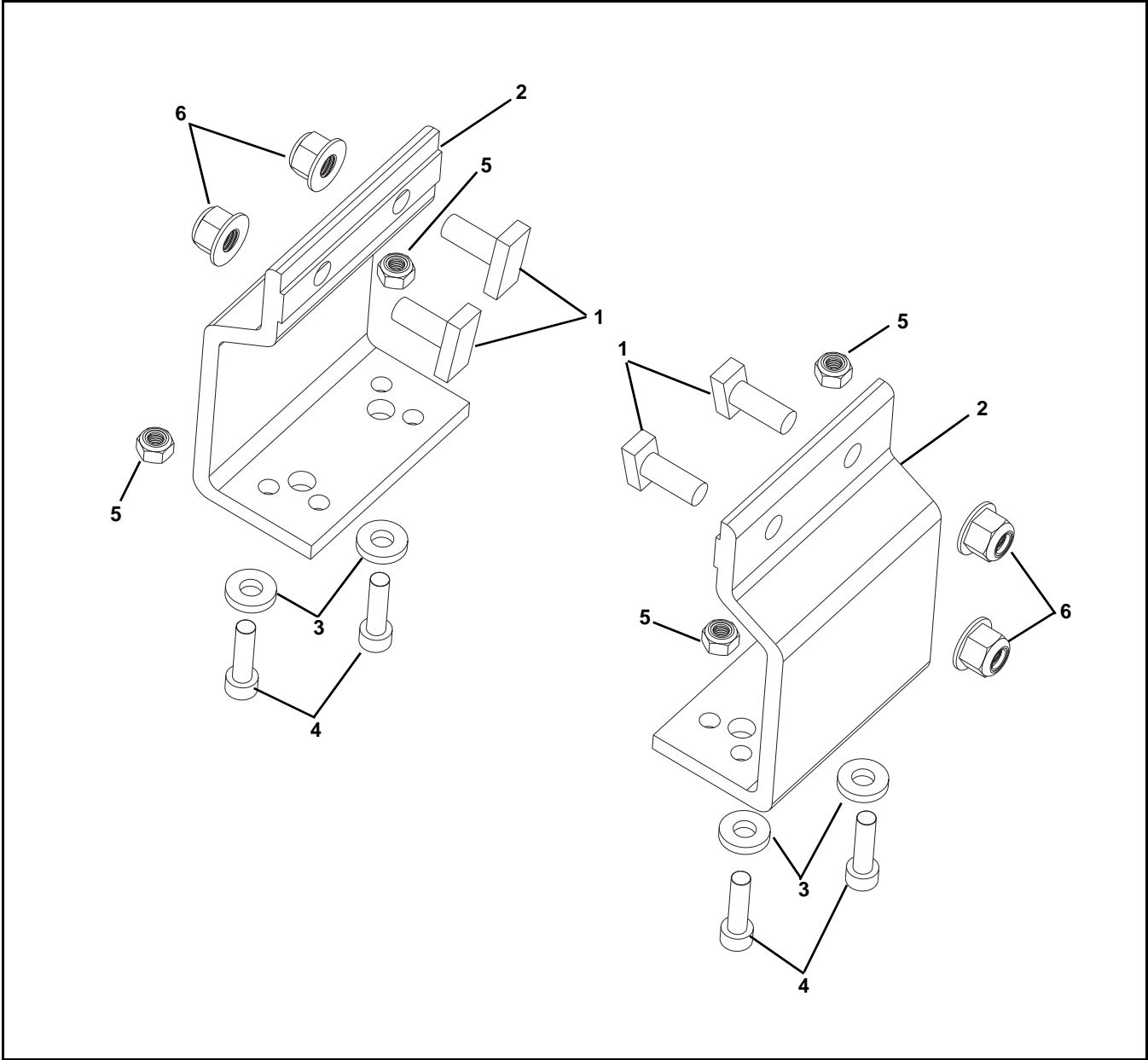


Item	Part Number	Description
1	802-046	Cam Bearing
2	802-110	Bearing
3	950620M	Low Head Cap Screw, M6-1.00 x 20 mm
4	203765	Locking Sprocket
5	807-2285	Cover
6	807-2286	Retaining Ring
7	807-2287	Hex Post
8	206886	Pulley
9	907-115	Socket Head Set Screw, #10-32 x 0.19
10	203229	Side Guide Plate
11	205711-260	Wear Bar
12	203231	Timing Belt Tensioner
13	205710-02	Side Plate
14	205726-260	Wear Rod
15	206343-260	Power Transfer Belt
16	205725-260	Tensioner Assembly
17	203264-260	Shaft Assembly

Item	Part Number	Description
18	203267-260	Square Key, 3/16" x 105 mm
19	205727-260	Pinch Guard
20	350505	Power Transfer Cover
21	605280P	Washer
22	910506M	Button Head Screw, M5-0.80 x 6 mm
23	950510M	Low Head Cap Screw, M5-0.80 x 10 mm
24	950612M	Low Head Cap Screw, M6-1.00 x 12 mm
25	950830M	Low Head Cap Screw, M8-1.25 x 30 mm
26	970510M	Socket Head Set Screw, M5-0.80 x 10 mm
27	605279P	Washer
28	814-065	Timing Belt 15 mm x 475 mm
29	990621M	Insert
30	807-2277	Washer
31	203765P	Sliding Sprocket
32	970606M	Cup Set Screw, M6-0.80 x 5 mm
33	911-005	Washer

Service parts can be obtained through your distributor or directly from Dorner Mfg. Corp. (800) 397-8664 or [customerservice@dorner.com](mailto:customerservice@dorner.com)

## Horizontal Mounting Brackets

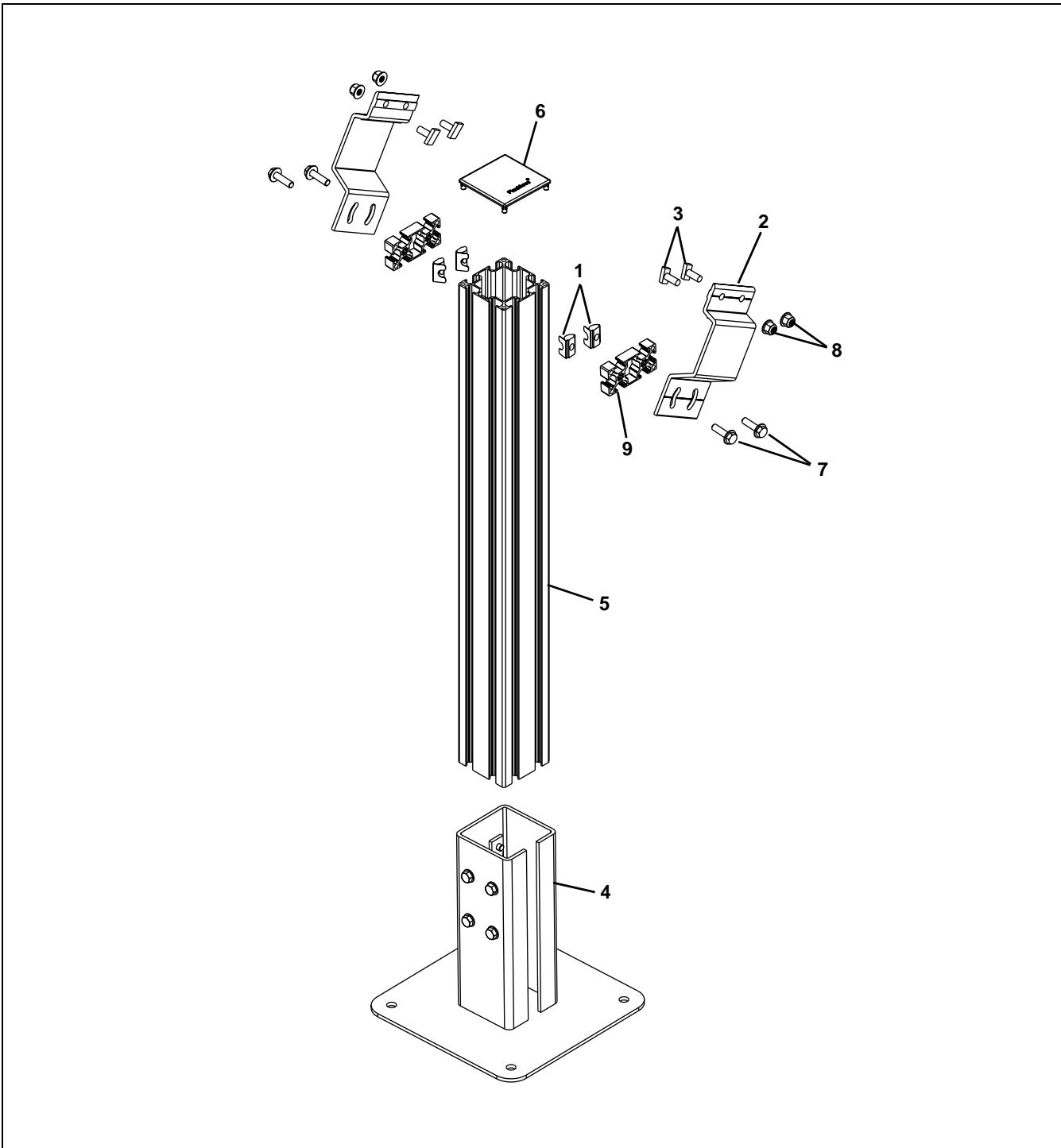


Item	Part Number	Description
1	FATB-20	Stud, M8 x 20 mm
2	FAHBS-80SPL	Mounting Bracket
3	605279P	Washer
4	920622M	Socket Head Screw, M6-1.00 x 22 mm
5	990602M	Hex Nut, M6-1.00
6	990812M	Flanged Hex Nut, M8-1.25

Service parts can be obtained through your distributor or directly from Dorner Mfg. Corp. (800) 397-8664 or customerservice@dorner.com

# Service Parts

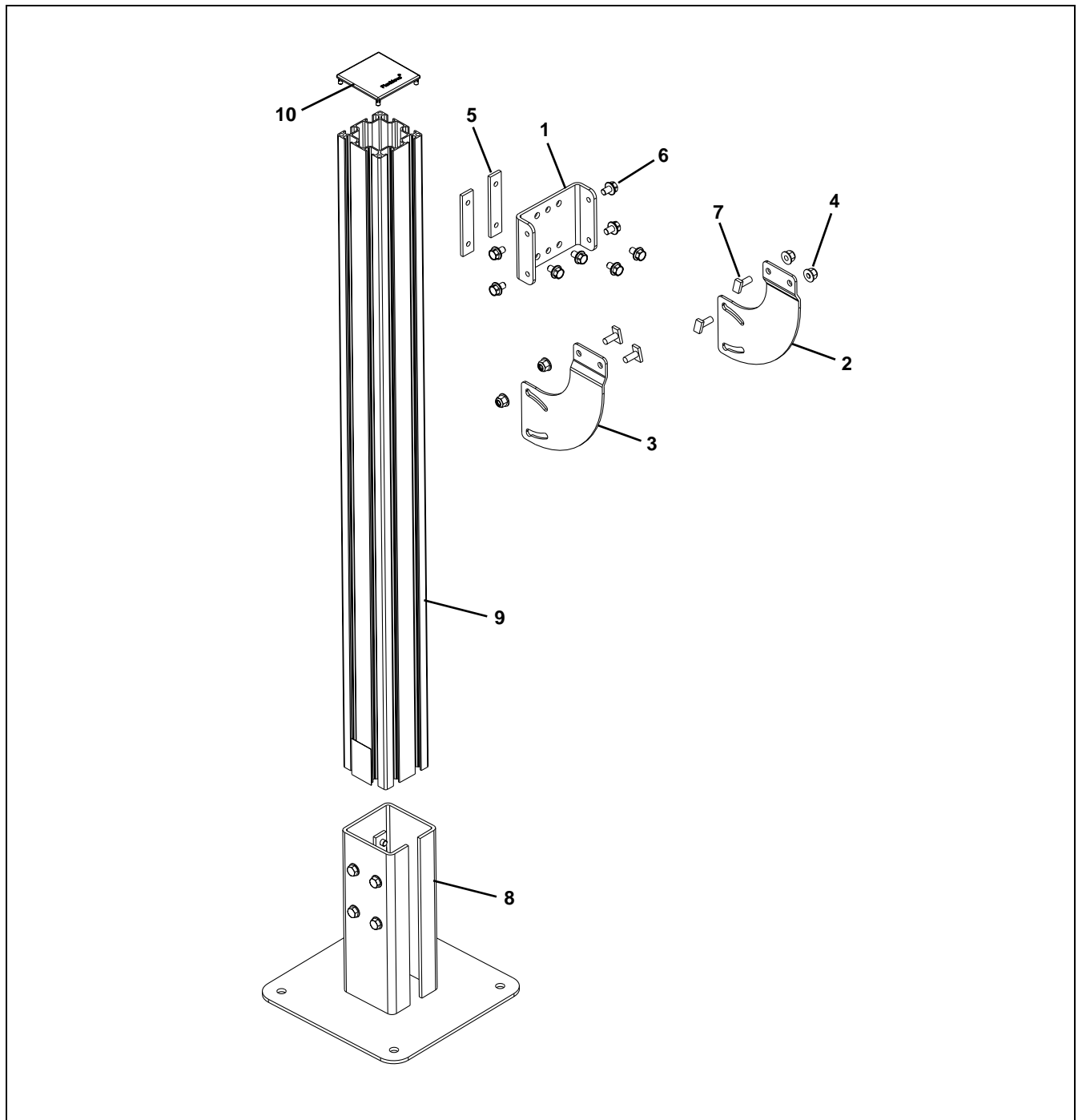
## Support Post - Conveyor Frame Mount



Item	Part Number	Description
1	FASL-M8	Spring Nut (x50)
2	210830-260	Mounting Bracket
3	FATB-20	T-Bolt, 20 mm (x50)
4	FBFT-80B	Stand Foot, w/Hardware
5	FBSB-80X80-LLLLL	Leg
6	FBEC-80	Cover
7	960870M	Hex Head Cap Screw, M8-1.25 x 70 mm

Item	Part Number	Description
8	990812M	Hex Nut, M8-1.25
9	207769-260	Spacer
LLLLL = Length in inches with 2 decimal places. Length Example: Length = 95.25" LLLLL = 09525		
Service parts can be obtained through your distributor or directly from Dorner Mfg. Corp. (800) 397-8664 or customerservice@dorner.com		

## Support Post - Motor Mount

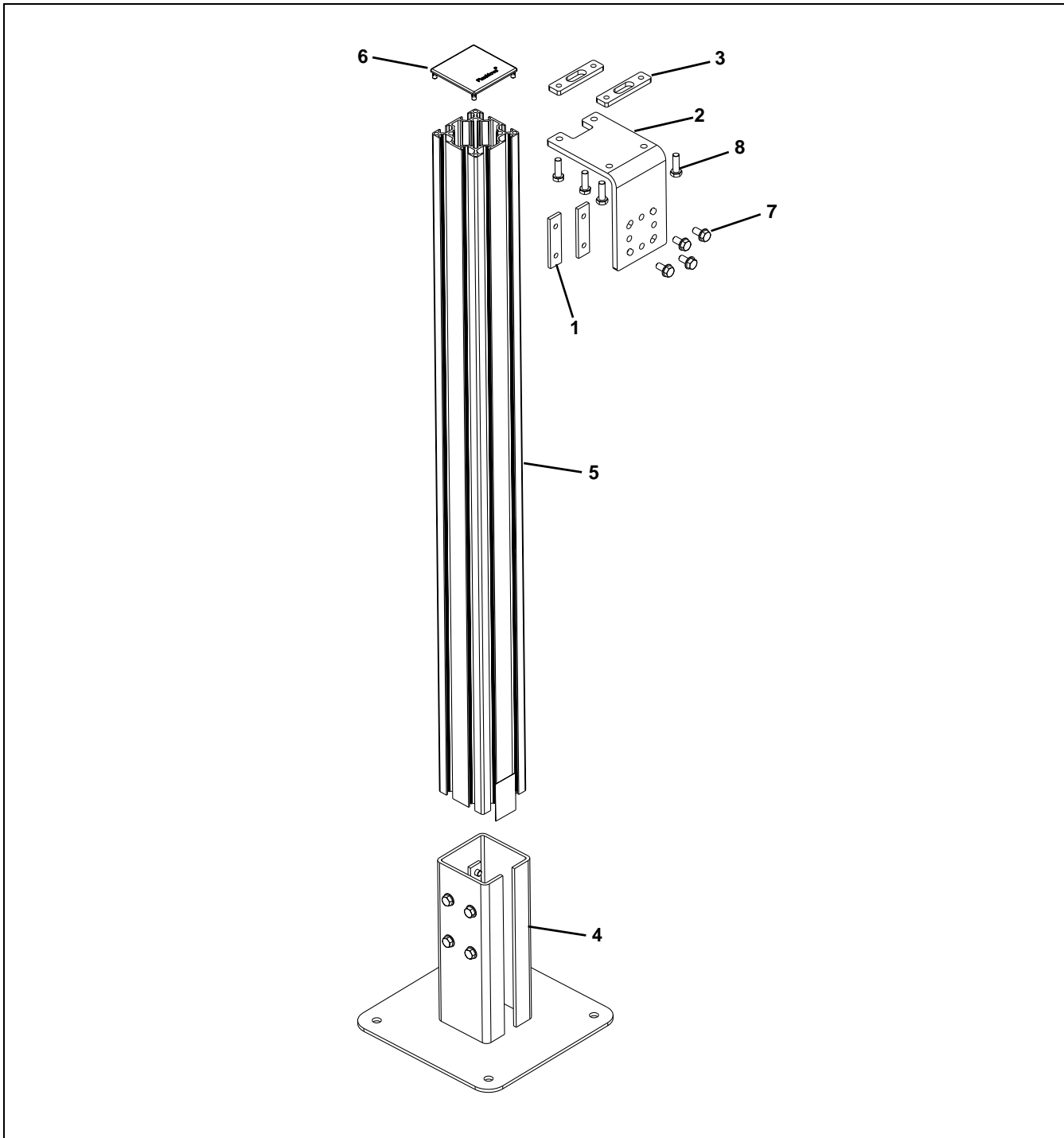


Item	Part Number	Description
1	207195-260	Stand Mounting Channel
2	207194-LH	Drive Tail Bracket, Left Hand
3	207194-RH	Drive Tail Bracket, Right Hand
4	990812M	Hex Nut, M8-1.25
5	FBCS-20X96	Connecting Strip, 20 x 96 mm (x10)
6	960882M	Flange Head Cap Screw, M8-1.25 x 12 mm
7	FATB-20	T-Bolt, 20 mm

Item	Part Number	Description
8	FBFT-80B	Stand Foot, w/Hardware
9	FBSB-80X80-LLLLL	Leg
10	FBEC-80	Cover
LLLLL = Length in inches with 2 decimal places. Length Example: Length = 95.25" LLLLL = 09525		
Service parts can be obtained through your distributor or directly from Dorner Mfg. Corp. (800) 397-8664 or customerservice@dorner.com		

# Service Parts

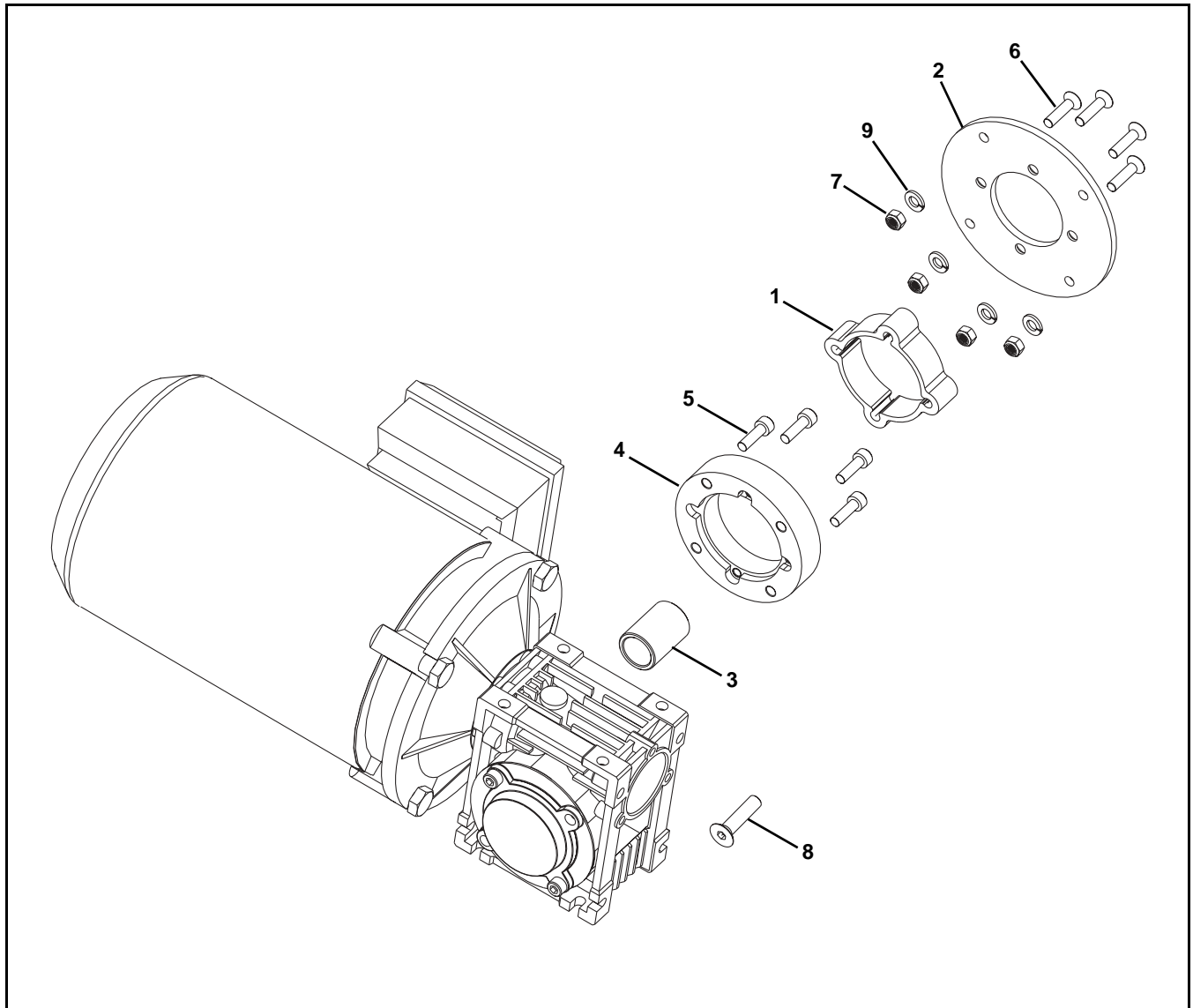
## Suspended Drive Stand



Item	Part Number	Description
1	FBCS-20X76	Connecting Strip, 20 x 76 mm (x10)
2	206887	Bracket
3	207275	Nut Bar
4	FBFT-80B	Stand Foot, w/Hardware
5	FBSB-80X80-LLLLL	Leg
6	FBEC-80	Cover)
7	960883M	Flange Head Cap Screw, M8-1.25 x 16 mm

Item	Part Number	Description
8	960825M	Hex Head Cap Screw, M8-1.25 x 25 mm
LLLLL = Length in inches with 2 decimal places.		
Length Example: Length = 95.25" LLLLL = 09525		
Service parts can be obtained through your distributor or directly from Dorner Mfg. Corp. (800) 397-8664 or customerservice@dorner.com		

## E-Drive Gearmotor Mounting Package

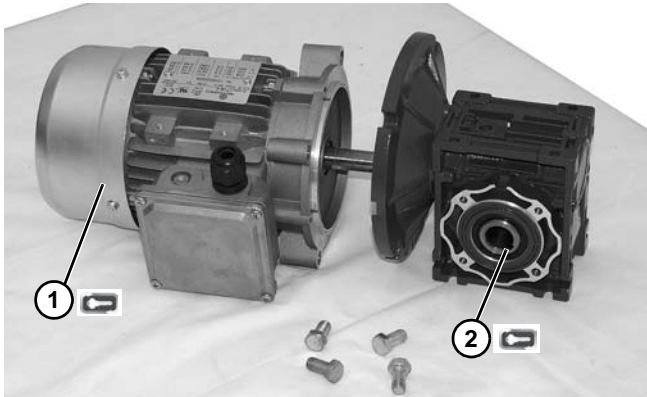




Item	Part Number	Description
1	202270-00075	Extrusion
2	202971	Drive Plate
3	203065	Drive Spacer
4	350115	Adapter Ring
5	920620M	Socket Head Screw, M6-1.00 x 20 mm
6	930625M	Flat Head Screw, M6-1.00 x 25 mm
7	990601M	Hex Nut, M6-1.00
8	931025M	Flat Head Screw, M10-1.50 x 25 mm
9	911-108	Washer

Service parts can be obtained through your distributor or directly from Dorner Mfg. Corp. (800) 397-8664 or [customerservice@dorner.com](mailto:customerservice@dorner.com)

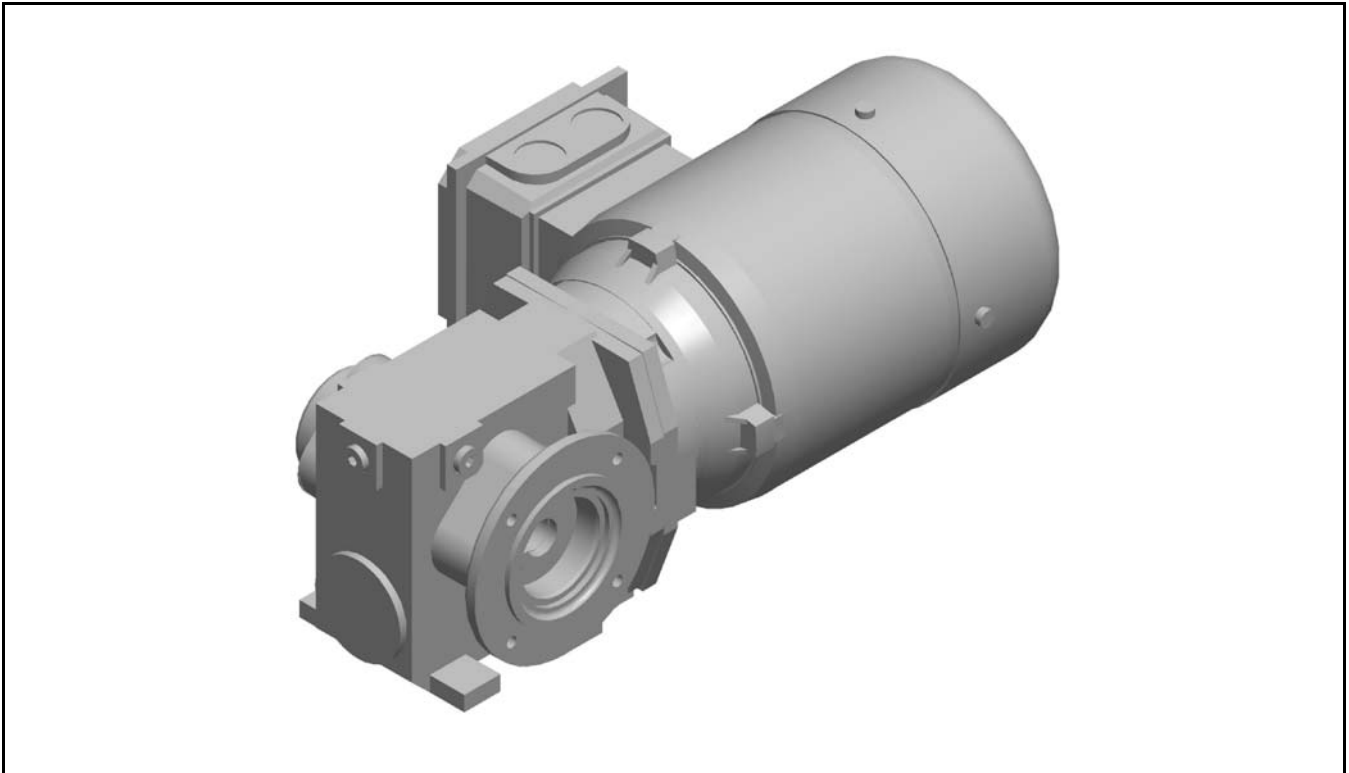
# Service Parts

## Standard Load 90° Industrial Gearmotors



Item	Part No.	Description
1 	62MES411FN	Motor, 0.25hp (0.19Kw), 115/230 Volts, 60 Hz, 1-Phase
	62MES423FN	Motor, 0.25hp (0.19Kw), 208–230/460 Volts, 60 Hz, 3-Phase
	22MSD3DEN	Motor, 0.25hp (0.19Kw), 130 VDC
	62MEH411FN	Motor, 0.5hp (0.37Kw), 115/230 Volts, 60Hz, 1-Phase
	32MES423FN	Motor, 0.5hp (0.37Kw) 208–230/460 Volts, 60Hz, 3 Phase
	62MHD9DEN	Motor, 0.5hp (0.37Kw), 90 VDC
	32MES423EN	Motor, 0.5hp (0.37Kw), 230 Volts, 3 Phase Inverter Duty
	32MHD9DEN	Motor, 0.75 hp, (0.56Kw), 90 VDC
2 	32M005EL	Gear Reducer, 5:1, NEMA 42CZ
	32M010EL	Gear Reducer, 10:1, NEMA 42CZ
	32M020EL	Gear Reducer, 20:1, NEMA 42CZ
	32M040EL	Gear Reducer, 40:1, NEMA 42CZ
	32M060EL	Gear Reducer, 60:1, NEMA 42CZ
	32M005ES	Gear Reducer, 5:1, NEMA 56C
	32M010ES	Gear Reducer, 10:1, NEMA 56C
	32M020ES	Gear Reducer, 20:1, NEMA 56C
	32M040ES	Gear Reducer, 40:1, NEMA 56C
	32M060ES	Gear Reducer, 60:1, NEMA 56C
	32M010EH	Gear Reducer, 10:1, NEMA 140 TC
Service parts can be obtained through your distributor or directly from Dorner Mfg. Corp. (800) 397-8664 or customerservice@dorner.com		

## Flange Mounted Motor (Direct Drive Tail)



Product Line		FK,FS,FM,FU,FV	FC,FL	FS	FM
Radius (M)		0.064	0.0675	0.044	0.049
Drive Type		Direct	Direct	Intermediate	Intermediate
Part Number					
Right Hand	Left Hand	Speed	Speed	Speed	Speed
FMM129RDS423EN	FMM129LDS423EN	5.2 m/min	5.5 m/min	3.6 m/min	4 m/min
FMM067RDS423EN	FMM067LDS423EN	10 m/min	10.6 m/min	6.9 m/min	7.7 m/min
FMM032RDS423EN	FMM032LDS423EN	21.3 m/min	22.5 m/min	14.6 m/min	16.3 m/min
FMM015RDS423EN	FMM015LDS423EN	45.8 m/min	48.3 m/min	31.5 m/min	35.1 m/min
FMM013RDS423EN	FMM013LDS423EN	52.2 m/min	55.1 m/min	35.9 m/min	40 m/min
FMM010RDS423EN	FMM010LDS423EN	68.7 m/min	72.5 m/min	47.3 m/min	52.6 m/min

Part Number	Volts	Phase	Hz	Power	Power	Speed	Torque	Torque	Ratio	Force
FMM129(X)DS423EN	230/460	3	60	0.18 kW	0.25 Hp	13 rpm	95 Nm	837 in-lb.	129 i	1484 N
FMM067(X)DS423EN	230/460	3	60	0.37 kW	0.50 Hp	25 rpm	79 Nm	699 in-lb.	67.5 i	1234 N
FMM032(X)DS423EN	230/460	3	60	0.55 kW	0.75 Hp	53 rpm	74 Nm	653 in-lb.	32.3 i	1156 N
FMM015(X)DS423EN	230/460	3	60	0.55 kW	0.75 Hp	114 rpm	39 Nm	341 in-lb.	15 i	609 N
FMM013(X)DS423EN	230/460	3	60	0.75 kW	1.00 Hp	130 rpm	48 Nm	425 in-lb.	13.3 i	750 N
FMM010(X)DS423EN	230/460	3	60	1.1 kW	1.50 Hp	171 rpm	56 Nm	490 in-lb.	10.2 i	875 N

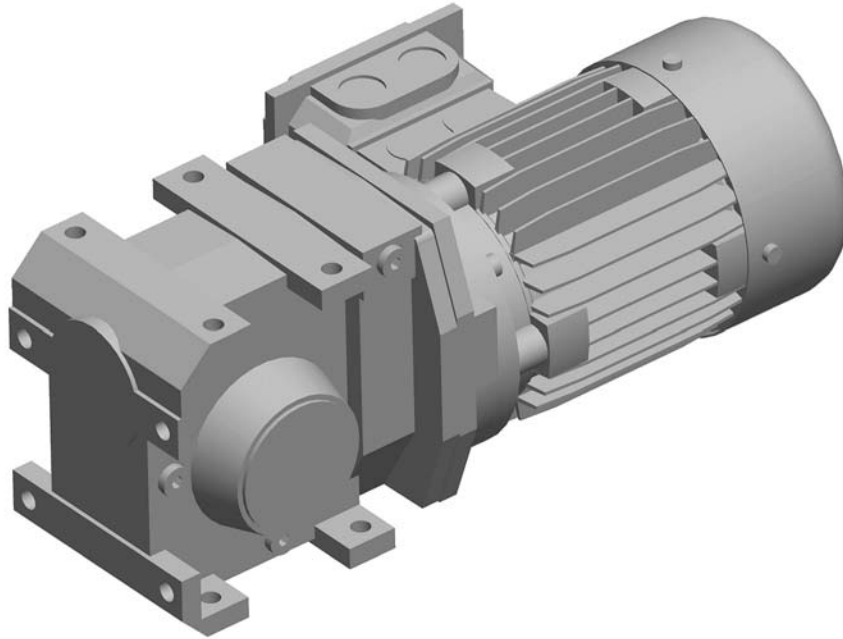
(X) = L or R for Right Hand or Left Hand Gearmotor matching RH or LH Drive

Note: speed range for 60 Hz gearmotors is 10 to 60 Hz or 6:1.

Service parts can be obtained through your distributor or directly from Dorner Mfg. Corp. (800) 397-8664 or [customerservice@dorner.com](mailto:customerservice@dorner.com)

# Service Parts

## Foot Mounted Motor (Suspended Drive Tail)



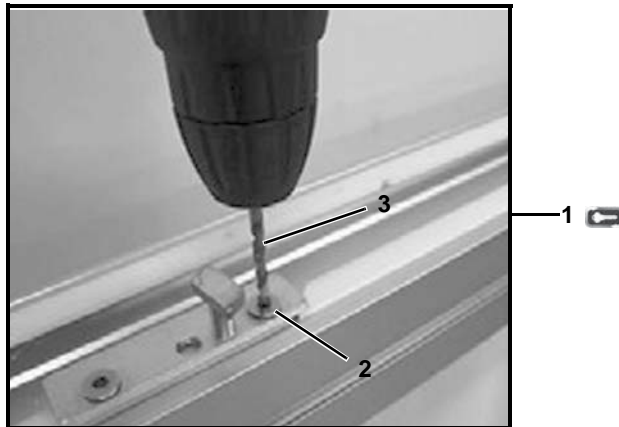
Product Line	FK,FS,FM,FU,FV	FC,FL
Radius (M)	0.064	0.0675
Drive Type	Suspended	Suspended
Part Number		
Right Hand	Left Hand	Speed
FMM129RSS423EN	FMM129LSS423EN	5.2 m/min
FMM067RSS423EN	FMM067LSS423EN	10 m/min
FMM032RSS423EN	FMM032LSS423EN	21.3 m/min
FMM015RSS423EN	FMM015LSS423EN	45.8 m/min
FMM013RSS423EN	FMM013LSS423EN	52.2 m/min
FMM010RSS423EN	FMM010LSS423EN	68.7 m/min

Part Number	Volts	Phase	Hz	Power	Power	Speed	Torque	Torque	Ratio	Force
FMM129(X)SS423EN	230/460	3	60	0.18 kW	0.25 Hp	13 rpm	95 Nm	837 in-lb.	129 i	1484 N
FMM067(X)SS423EN	230/460	3	60	0.37 kW	0.50 Hp	25 rpm	79 Nm	699 in-lb.	67.5 i	1234 N
FMM032(X)SS423EN	230/460	3	60	0.55 kW	0.75 Hp	53 rpm	74 Nm	653 in-lb.	32.3 i	1156 N
FMM015(X)SS423EN	230/460	3	60	0.55 kW	0.75 Hp	114 rpm	39 Nm	341 in-lb.	15 i	609 N
FMM013(X)SS423EN	230/460	3	60	0.75 kW	1.00 Hp	130 rpm	48 Nm	425 in-lb.	13.3 i	750 N
FMM010(X)SS423EN	230/460	3	60	1.1 kW	1.50 Hp	171 rpm	56 Nm	490 in-lb.	10.2 i	875 N

(X) = L or R for Right Hand or Left Hand Gearmotor matching RH or LH Drive  
 Note: speed range for 60Hz gearmotors is 10 to 60 Hz or 6:1.

Service parts can be obtained through your distributor or directly from Dorner Mfg. Corp. (800) 397-8664 or customerservice@dorner.com

## Slide Rail Replacement Tool



Item	Part Number	Description
1	203475	Slide Rail Replacement Tool Kit
2	807-2694	Nylon Socket Screw, #10-32 x 1.00
3	896-1008	Drill Bit, #18, 0.1695"

Service parts can be obtained through your distributor or directly from Dorner Mfg. Corp. (800) 397-8664 or [customerservice@dorner.com](mailto:customerservice@dorner.com)

## Slide Rail

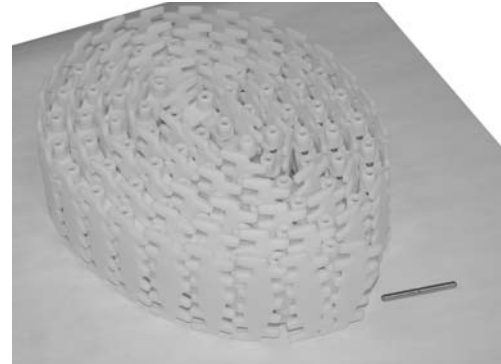
Item	Part No.	Description
1	FASR-25	Standard HDPE (25 M Roll)
	FASR-25U	Standard Low Friction UHMW (25 M Roll)
	FASR-25A	Special Conductive (25 M Roll)
	FASR-25X	Special HI Speed (25 M Roll)
	FASR-25P	Special Abrasive Resistant (25 M Roll)
	FASR-25T	Special Abrasive Resistant, High Load (25 M Roll)
	FASR-25MDS	Special High Load Nylon (25 M Roll)

Service parts can be obtained through your distributor or directly from Dorner Mfg. Corp. (800) 397-8664 or [customerservice@dorner.com](mailto:customerservice@dorner.com)

## Replacement Chain

Replacement chain sold per box containing 5 meters of chain.

For specific chain details see FlexMove Engineering Manual.



Part Number	Description
FVPC-5	Standard Plastic Chain
FVFT-5	Friction Top Chain
FVFT-5R	Friction Top Roller Chain
FVPC-5R	Plain Chain with Rollers
FVPC-5M	Twist Chain

Service parts can be obtained through your distributor or directly from Dorner Mfg. Corp. (800) 397-8664 or [customerservice@dorner.com](mailto:customerservice@dorner.com)

## Belt Removal Tool



Item	Part Number	Description
1	203480	Belt Removal Tool

Service parts can be obtained through your distributor or directly from Dorner Mfg. Corp. (800) 397-8664 or [customerservice@dorner.com](mailto:customerservice@dorner.com)

# Service Parts

## Side Cutter



Item	Part Number	Description
1	897-1098	Side Cutter
Service parts can be obtained through your distributor or directly from Dorner Mfg. Corp. (800) 397-8664 or customerservice@dorner.com		

## Bearing Tool



Item	Part Number	Description
1	206891	Bearing Tool
Service parts can be obtained through your distributor or directly from Dorner Mfg. Corp. (800) 397-8664 or customerservice@dorner.com		

## Utility Cutter



Item	Part Number	Description
1	897-1099	Utility Cutter
Service parts can be obtained through your distributor or directly from Dorner Mfg. Corp. (800) 397-8664 or customerservice@dorner.com		



# Return Policy

Returns must have prior written factory authorization or they will not be accepted. Items that are returned to Dorner without authorization will not be credited nor returned to the original sender. When calling for authorization, please have the following information ready for the Dorner factory representative or your local distributor:

1. Name and address of customer.
2. Dorner part number(s) of item(s) being returned.
3. Reason for return.
4. Customer's original order number used when ordering the item(s).
5. Dorner or distributor invoice number. Include part serial number if available.

A representative will discuss action to be taken on the returned items and provide a Returned Materials Authorization (RMA) number for reference. RMA will automatically close 30 days after being issued. To get credit, items must be new and undamaged. There will be a return charge on all items returned for credit, where Dorner was not at fault. It is the customer's responsibility to prevent damage during return shipping. Damaged or modified items will not be accepted. The customer is responsible for return freight.

Product Line	Product Type								Engineered to order parts
	Standard Products								
	Conveyors	Gearmotors & Mounting Packages	Support Stands	Accessories	Spare Parts (non-belt)	Spare Belts - Standard Flat Fabric	Spare Belts - Cleated & Spec. Fabric	Spare Belts - Plastic Chain	All equipment and parts
1100 Series	30% return fee for all products except: 50% return fee for conveyors with modular belt, cleated belt or speciality belts  All Electrical items are assigned original manufacturers return policy.						non-returnable		case-by-case
2200 Series									
3200 Series									
Pallet Systems									
FlexMove/SmartFlex									
GAL Series									
All Electrical									
7100 Series	50% return fee for all products						non-returnable		case-by-case
7200/7300 Series									
AquaGard 7350 Series Version 2									
GES Series									
AquaGard 7350/7360 Series	non-returnable								
AquaPruf Series	non-returnable								

Returns will not be accepted after 60 days from original invoice date. The return charge covers inspection, cleaning, disassembly, disposal and reissuing of components to inventory. If a replacement is needed prior to evaluation of returned item, a purchase order must be issued. Credit (if any) is issued only after return and evaluation is complete.

Dorner has representatives throughout the world. Contact Dorner for the name of your local representative. Our Customer Service Team will gladly help with your questions on Dorner products.

For a copy of Dorner's Warranty, contact Dorner, an authorized sales channel or visit our website: [www.dorner.com](http://www.dorner.com).

For replacement parts, contact an authorized Dorner Service Center or the factory.

[www.dorner.com](http://www.dorner.com)



© Dorner Mfg. Corp. 2018. All Rights Reserved.

851-903 Rev. C

Printed in U.S.A.

## Dorner – North & South America

### Dorner – U.S.A.

**Headquarters**  
 975 Cottonwood Ave  
 Hartland, WI 53029, USA  
 (800) 397-8664  
 (262) 367-7600  
[info@dorner.com](mailto:info@dorner.com)

### Dorner – Canada

100-5515 North Service Road  
 Burlington, Ontario L7L 6G6  
 Canada  
 (289) 208-7306  
[info@dorner.com](mailto:info@dorner.com)

### Dorner – Latin America

Carretera a Nogales #5297, Nave 11.  
 Parque Industrial Nogales  
 Zapopan, Jalisco C.P. 45222 México  
 +52.33.30037400 | [info.latinamerica@dorner.com](mailto:info.latinamerica@dorner.com)

## Dorner – Europe

Karl-Heinz-Beckurts-Straße 7  
 52428 Jülich, Germany  
 +49 (0) 2461/93767-0 | [info.europe@dorner.com](mailto:info.europe@dorner.com)

## Dorner – Asia

128 Jalan Permatang Damar Laut, Bayan Lepas 11960  
 Penang, Malaysia  
 +604-626-2948 | [info.asia@dorner.com](mailto:info.asia@dorner.com)