



2700 Series Conveyors

Installation, Maintenance & Parts Manual



Mid Drive



End Drive

For other service manuals visit our website at:
www.dornerconveyors.com/manuals-literature

<hr/> <p>Record Conveyor Serial Number Here</p>
--

Table of Contents

Introduction	3	Pinion Replacement.....	34
Warnings – General Safety	4	Service Parts.....	37
Product Description	5	End Drive Tail	37
Specifications	5	iDrive Tail	38
Models:	5	iDrive Controller	39
Flat Belt 2700 Series End Drive Conveyor.....	5	Idler Tail.....	40
Flat Belt 2700 Series iDrive Conveyor	5	5/8" (16 mm) Nosebar Tail.....	41
Flat Belt 2700 Series Mid Drive Conveyor.....	6	Mid Drive Module.....	42
Conveyor Supports	6	Frame Assembly.....	43
End Drive and iDrive Conveyor Supports	6	#04 Profile - 3.00" (76 mm) Aluminum Side.....	44
Maximum Distances:.....	6	#05 Profile - 1.50" (38 mm) Aluminum Side.....	45
Mid Drive Conveyor Supports	6	#07 Profile - Low to Side Wiper	46
Maximum Distances:.....	6	#09 Profile - Low to High Side	47
End/Mid Drive Conveyor Specifications.....	7	#10 Profile - 0.5" (13 mm) Extruded Plastic Side.....	48
iDrive Conveyor Specifications.....	7	#13, 33 & 43 Profile - Adjustable Guiding	49
iDrive Motor Specifications.....	8	#14, 34 & 44 Profile - Tool-Less Adjustable Guiding... ..	50
Fastener Torque Specifications.....	8	#16, 36 & 46 Profile - Outboard Adjustable Guiding	51
Installation	9	#19, 39 & 49 Profile - Horizontal Adjustable Guiding	52
Required Tools.....	9	#20, 40 & 50 Profile - Tool-Less	
Recommended Installation Sequence	9	Horizontal Adjustable Guiding	53
Conveyors Up to 12 ft (3658 mm).....	9	Mounting Brackets	54
Conveyors Longer Than 12 ft (3658 mm).....	9	Mounting Brackets Assembled to the Tail.....	55
Mounting Brackets.....	11	Connecting Assembly without Stand Mount.....	56
Return Rollers	12	Connecting Assembly with Stand Mount.....	56
iDrive Controller.....	12	Return Roller	57
Assembly	12	Conveyor Belt Part Number Configuration.....	58
Setup.....	14	Notes	59
Guide Clips	16	Return Policy.....	60
Adjustable Guides.....	16		
Preventive Maintenance and Adjustment	18		
Required Tools.....	18		
Standard Tools.....	18		
Checklist	18		
Lubrication	18		
Maintaining Conveyor Belt	18		
Troubleshooting	18		
Cleaning	18		
Conveyor Belt Replacement	18		
Conveyor Belt Replacement Sequence	18		
Belt Removal for End Drive and iDrive Conveyors.....	19		
Belt Removal for Mid Drive Conveyors	20		
Belt Installation for End Drive and iDrive Conveyors.....	21		
Conveyor Belt Tensioning	22		
Conveyor Belt Tracking.....	23		
V-Guided Belts.....	23		
Non V-Guided Belts.....	23		
End Drive Conveyor Belts	23		
Pulley Replacement	24		
A – Drive Pulley Removal	24		
B – iDrive Pulley Removal	25		
C – Idler Pulley Removal.....	27		
D – 5/8" (16 mm) Nosebar Pulley Removal	28		
E – Mid Drive Module Pulley Removal	30		
iDrive Motor Replacement	32		

IMPORTANT

<i>Some illustrations may show guards removed. DO NOT operate equipment without guards.</i>

Upon receipt of shipment:

- Compare shipment with packing slip. Contact factory regarding discrepancies.
- Inspect packages for shipping damage. Contact carrier regarding damage.
- Accessories may be shipped loose. See accessory instructions for installation.

Dorner's Limited Warranty applies.

Dorner has convenient, pre-configured kits of Key Service Parts for all conveyor products. These time saving kits are easy to order, designed for fast installation, and guarantee you will have what you need when you need it. Key Parts and Kits are marked in the Service Parts section of this manual with the Performance Parts Kits logo .

Dorner reserves the right to make changes at any time without notice or obligation.

Warnings – General Safety

⚠ WARNING

The safety alert symbol, black triangle with white exclamation, is used to alert you to potential personal injury hazards.

⚠ DANGER



SEVERE HAZARD!

KEEP OFF CONVEYORS. Climbing, sitting, walking or riding on conveyor will result in death or serious injury.

⚠ WARNING



SEVERE HAZARD!

LOCK OUT POWER before removing guards or performing maintenance. Exposed moving parts can cause serious injury.

⚠ WARNING



BURN HAZARD!

DO NOT TOUCH the motor while operating, or shortly after being turned off. Motors may be **HOT** and can cause serious burn injuries.

⚠ WARNING



PUNCTURE HAZARD!

Handle drive shaft keyway with care. It may be sharp and could puncture the skin, causing serious injury.

⚠ DANGER



EXPLOSION HAZARD!

- **DO NOT OPERATE CONVEYORS IN AN EXPLOSIVE ENVIRONMENT.** The electric gearmotor generates heat and could ignite combustible vapors.
- Failure to comply will result in death or serious injury.

⚠ WARNING



CRUSH HAZARD!

- **DO NOT** place hands or fingers inside the conveyor while it is running.
- **DO NOT** wear loose garments while operating the conveyor. Loose garments can become caught up in the conveyor.
- Failure to comply could result in serious injury.

⚠ WARNING



CRUSH HAZARD!

- **SUPPORT CONVEYOR SECTIONS PRIOR TO LOOSENING STAND HEIGHT OR ANGLE ADJUSTMENT SCREWS.**
- Loosening stand height or angle adjustment screws may cause conveyor sections to drop down, causing serious injury.

⚠ WARNING



SEVERE HAZARD!

- Dornier cannot control the physical installation and application of conveyors. Taking protective measures is the responsibility of the user.
- When conveyors are used in conjunction with other equipment or as part of a multiple conveyor system, **CHECK FOR POTENTIAL PINCH POINTS** and other mechanical hazards before system start-up.
- Failure to comply could result in serious injury.

Product Description

Typical Conveyor Components:

1	Conveyor
2	Gearmotor Mounting Package
3	Gearmotor
4	Guiding & Accessories
5	Mounting Brackets
6	Return Rollers
7	Support Stand
8	Variable Speed Controller
9	Drive End
10	Idler/Tension End

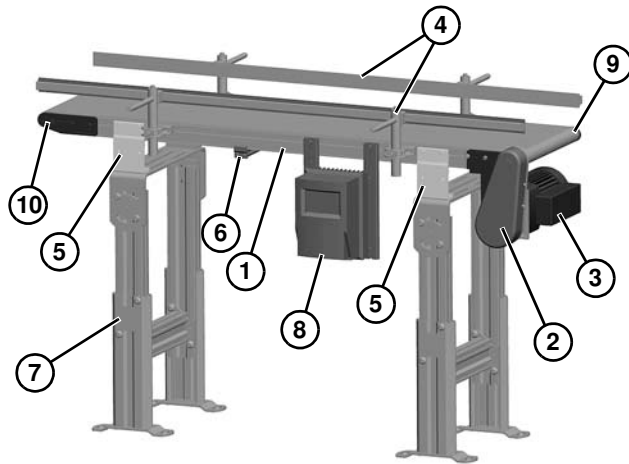
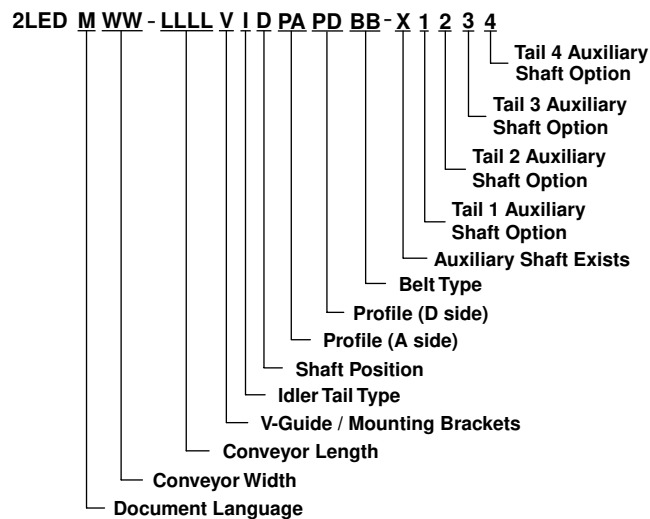

Figure 1

Specifications

Models:

Flat Belt 2700 Series End Drive Conveyor



Flat Belt 2700 Series iDrive Conveyor

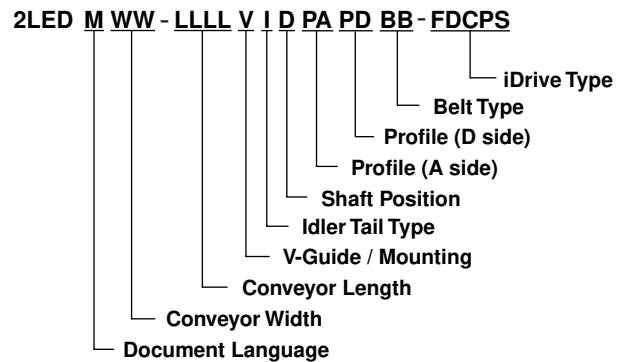

Specifications

Flat Belt 2700 Series Mid Drive Conveyor

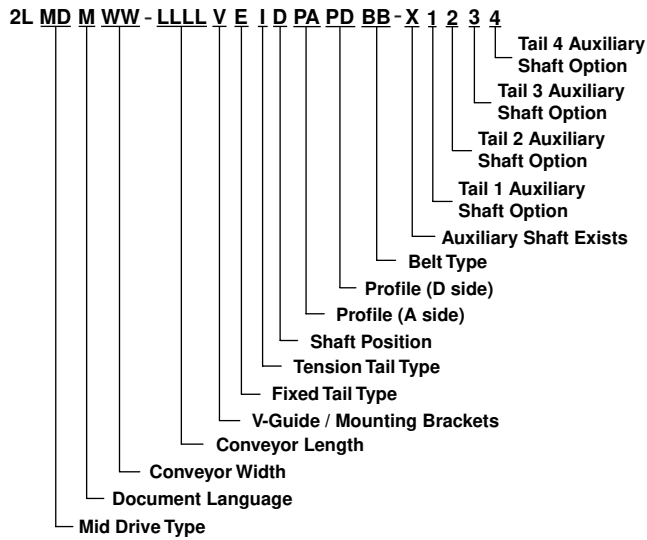

See Engineering manual for details.

Conveyor Supports

End Drive and iDrive Conveyor Supports

Maximum Distances:

- 1 = 24" (610 mm)
- 2 = 18" (457 mm)
- 3 = 96" (2438 mm)

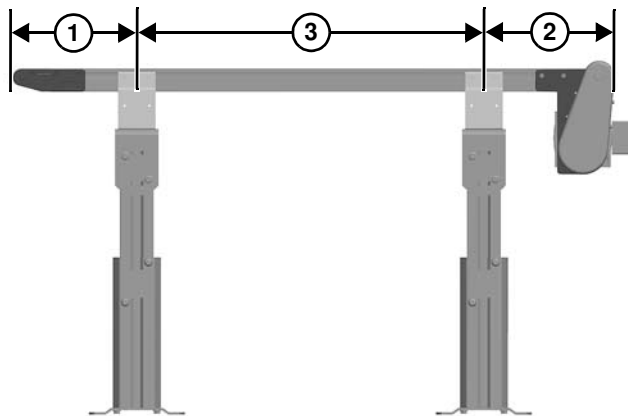

Figure 2

Mid Drive Conveyor Supports

Maximum Distances:

- 1 = 24" (610 mm) (Idler End)
- 2 = 96" (2438 mm)**

** For conveyors longer than 12 ft (3658 mm), install support at joint.

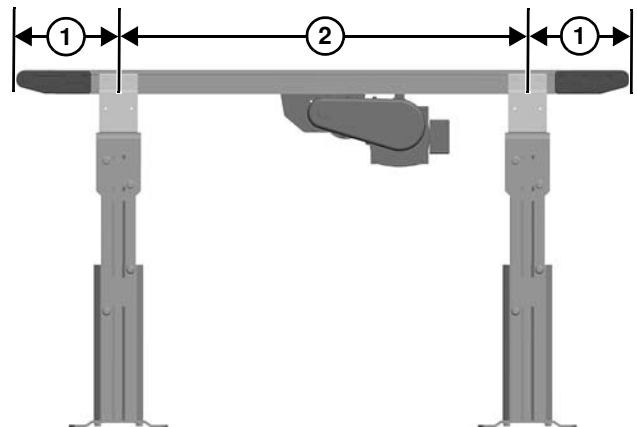

Figure 3

End/Mid Drive Conveyor Specifications

Conveyor Width Reference (WW)	10, 12, 14, 16, 18, 20, 22, 24, 26, 28, 30, 32, 34, 36
Conveyor Belt Width	10" (254 mm), 12" (305 mm), 14" (356 mm), 16" (406 mm), 18" (457 mm), 20" (508 mm), 22" (559 mm), 24" (609 mm), 26" (660 mm), 28" (711 mm), 30" (762 mm), 32" (813 mm), 34" (864 mm), 36" (914 mm)
Maximum Belt Speed*	400 ft/minute (122 m/minute)
Maximum Conveyor Load* (See NOTE Below)	150 lbs (68 kg)
Belt Travel	7.4" (189 mm) per revolution of pulley
End Drive Conveyor Length Reference (LLLL)	0170 to 2400 in 001 increments
End Drive Conveyor Length	1.70 ft (508 mm) to 24 ft (7,315 mm) in 0.12" (3 mm) increments
Mid Drive Conveyor Length Reference (LLLL)	0200 to 1800 in 001 increments
Mid Drive Conveyor Length	2 ft (610 mm) to 18 ft (5,486 mm) in 0.12" (3 mm) increments
Belt Take-up	0.38" (9.5 mm) of stroke = 1.1" (28 mm) of belt take-up

* See Engineering manual for details.

iDrive Conveyor Specifications

Conveyor Width Reference (WW)	10, 12, 14, 16, 18, 20, 22, 24, 26, 28, 30, 32, 34, 36					
Conveyor Belt Width	10" (254 mm), 12" (305 mm), 14" (356 mm), 16" (406 mm), 18" (457 mm), 20" (508 mm), 22" (559 mm), 24" (609 mm), 26" (660 mm), 28" (711 mm), 30" (762 mm), 32" (813 mm), 34" (864 mm), 36" (914 mm)					
Speed Range	3.3 to 33 ft/ minute (1 to 10 m/minute)	4.9 to 49 ft/ minute 1.5 to 15 m/minute)	6.6 to 66 ft/ minute (2 to 20 m/minute)	8.2 to 82 ft/ minute (2.5 to 25 m/minute)	14.8 to 148 ft/ minute (4.5 to 45 m/minute)	20 to 200 ft/ minute (6.1 to 61 m/minute)
Maximum Conveyor Load* (See NOTE Below)	165 lbs (75 kg)	108 lbs (49 kg)	75 lbs (34 kg)	59 lbs (27 kg)	26 lbs (12 kg)	15 lbs (7 kg)
Belt Travel	7.4" (189 mm) per revolution of pulley					
Conveyor Length Reference (LLLL)	0170 to 1000 in 001 increments					
Conveyor Length	1.70 ft (508 mm) to 10 ft (3,048 mm) in 0.12" (3 mm) increments					
Belt Take-up	0.38" (9.5 mm) of stroke = 0.71" (18 mm) of belt take-up					

* See Engineering manual for details.

NOTE
<p><i>Maximum conveyor loads are based on:</i></p> <ul style="list-style-type: none"> • <i>Non-accumulating product</i> • <i>Product moving toward gearmotor</i> • <i>Conveyor being mounted horizontally</i> • <i>Conveyor being located in a dry environment</i> • <i>Conveyor equipped with standard belt only</i>

Specifications

iDrive Motor Specifications

Voltage	24 Volt DC
Output Power	40 watt
Rated Current	2.5 amp
Starting Current	3.0 amp
Ambient Temperature	14° ~ 104° F (-10° ~ 40° C) (No Condensation)
Duty Cycle	0.5 sec ON / 0.50 sec OFF Minimum
Operation	Load/Current without Overheating

Gearmotor Ratios	Belt Speed
11:1	20.1-201 fpm (6.1-61 mpm)
15:1	14.7-147 fpm (4.5-45 mpm)
18:1	12-120 fpm (3.7-37 mpm)
27:1	8.2-82 fpm (2.5-25 mpm)
33:1	6.7-67 fpm (2.0-20 mpm)
45:1	4.9-49 fpm (1.5-15 mpm)
67:1	3.3-33 fpm (1.0-10 mpm)

Fastener Torque Specifications

	Flat Head		Socket Head		Button/Low Head		Set Screw	
	Size	Torque	Size	Torque	Size	Torque	Size	Torque
M4 x 0.7	2.5 mm	3.4 Nm (30 in lbs)	3 mm	5.9 Nm (52 in lbs)	2.5 mm	2.9 Nm (26 in lbs)	2 mm	2.1 Nm (19 in lbs)
M5 x 0.8	3 mm	6.9 Nm (61 in lbs)	4 mm	12.0 Nm (106 in lbs)	3 mm	5.9 Nm (52 in lbs)	2.5 mm	4.7 Nm (42 in lbs)
M6 x 1.0	4 mm	12.0 Nm (106 in lbs)	5 mm	20.3 Nm (180 in lbs)	4 mm	10.0 Nm (89 in lbs)	3 mm	7.7 Nm (68 in lbs)
M8 x 1.25	5 mm	28.0 Nm (248 in lbs)	6 mm	48.8 Nm (432 in lbs)	5 mm	24.0 Nm (212 in lbs)	4 mm	17.8 Nm (158 in lbs)
M10 x 1.5	6 mm	56.0 Nm (496 in lbs)	8 mm	97.5 Nm (863 in lbs)	6 mm	48.0 Nm (425 in lbs)	5 mm	35.0 Nm (310 in lbs)

NOTE

Conveyor **MUST** be mounted straight, flat, and level within confines of conveyor. Use a level (**Figure 4, item 1**) for setup.

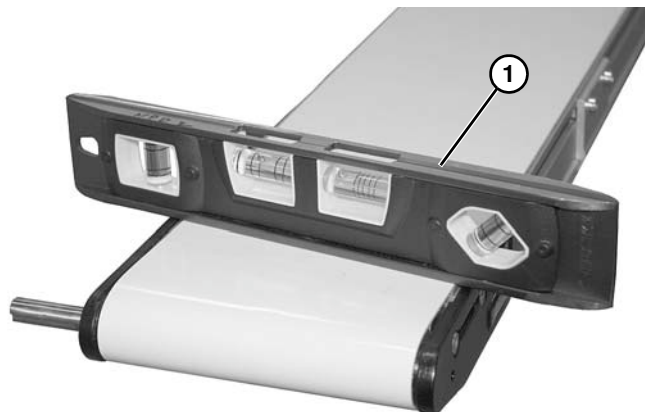

Figure 4

Required Tools

- Hex-key wrenches: 3 mm, 4 mm, 5 mm
- Level
- Torque wrench

Recommended Installation Sequence

- Assemble conveyor (if required)
- Attach mounting brackets to conveyor
- Attach conveyor to stands
- Install return rollers on conveyor (optional)
- Mount gearmotor mounting package (See Gearmotor Mounting Package manual.)
- Attach guides/accessories.

Conveyors Up to 12 ft (3658 mm)

No assembly is required. Install mounting brackets and return rollers. Refer to “Mounting Brackets” on page 11 and “Return Rollers” on page 12.

Conveyors Longer Than 12 ft (3658 mm)

1. Locate and arrange conveyor sections by section labels (**Figure 5, item 1**).

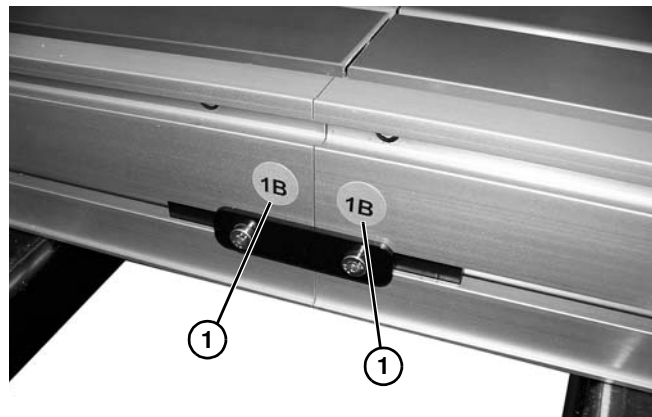



Figure 5

2. Follow the corresponding instructions below:

a. Idler Tail

b. End Drive Tail

c. iDrive Tail

- a. On idler end of conveyor, identified with a  label (**Figure 6, item 1**), push in head plate assembly (**Figure 6, item 2**):

- On both sides of conveyor, loosen and move cam tracking assemblies (**Figure 6, item 3**) (if equipped) away from head plates.

- Loosen fastening screws (**Figure 6, item 4**) and push head plate assembly inward.

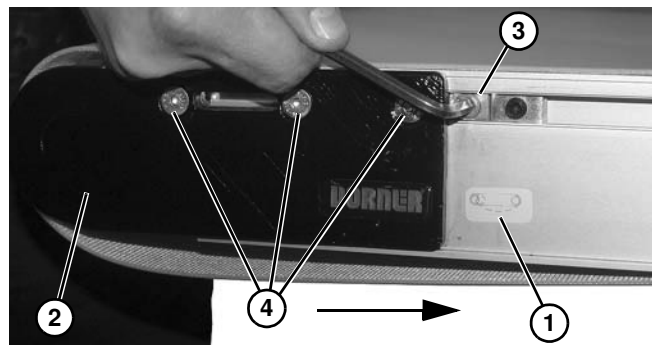

Figure 6

Installation

- b. On end drive of the conveyor, push in head plate assembly (**Figure 7, item 1**):
- On both sides of conveyor, loosen fastening screws (**Figure 7, item 2**).
 - On both sides of conveyor, rotate cam tracking assemblies (**Figure 7, item 3**) to move head plate assembly inward.

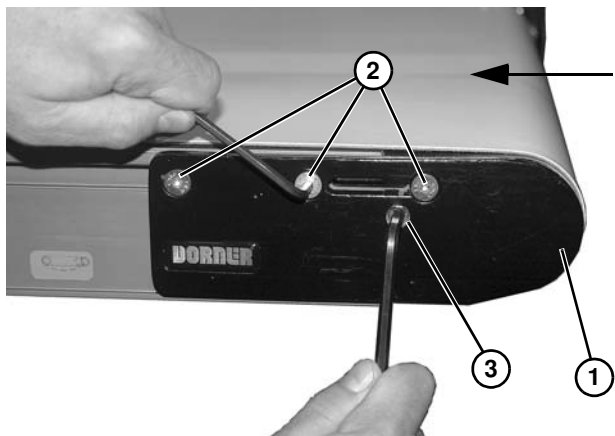

Figure 7

- c. On iDrive end of the conveyor, push in head plate assembly (**Figure 8, item 1**):
- Remove middle screw (**Figure 8, item 2**) from idrive head plate assembly (**Figure 8, item 1**) on each side of conveyor.

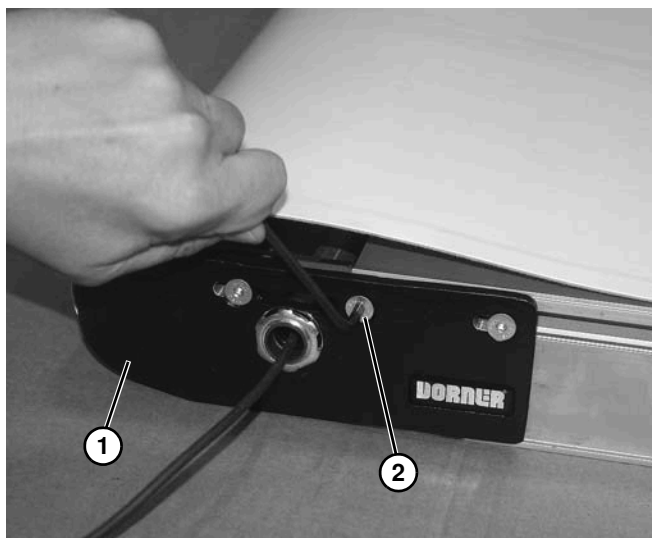

Figure 8

- Loosen outer fastening screws (**Figure 9, item 1**) from idrive head plate (**Figure 9, item 2**) (on each side of conveyor) to allow head plate assembly to slide in slots (**Figure 9, item 3**). Push head plate inward toward conveyor.

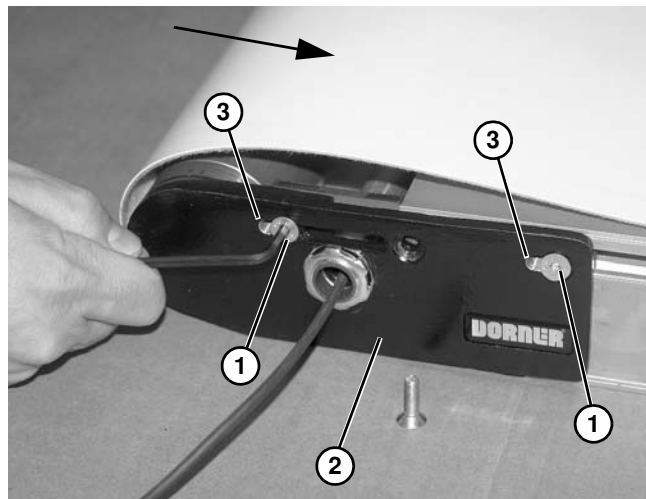

Figure 9

3. Orient belt so splice outer fingers (**Figure 10, item 1**) point in the direction of belt travel as identified by the conveyor directional label (**Figure 10, item 2**).

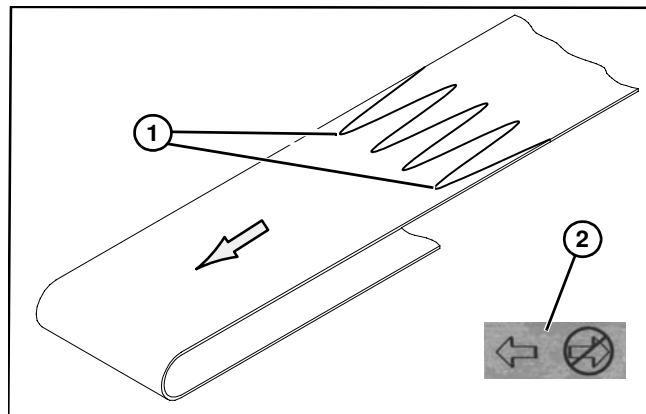

Figure 10

NOTE

Verify V-Guide on belt (**Figure 11, item 1**), is aligned with V-Guide in frame (**Figure 11, item 2**) and tails (**Figure 11, item 3**).

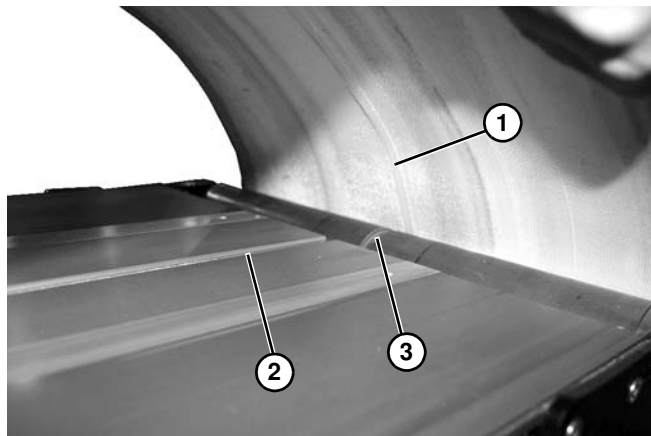

Figure 11

4. Roll out conveyor belt and place conveyor frame sections (**Figure 12, item 1**) into belt loop.

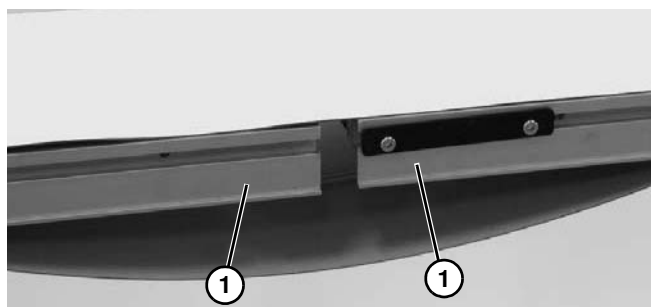

Figure 12

5. Join conveyor sections and install frame connector plates (**Figure 13, item 1**) or connector/mount brackets (**Figure 13, item 2**) and screws (**Figure 13, item 3**) on both sides as indicated. Tighten screws to 60 in-lb (7 Nm).

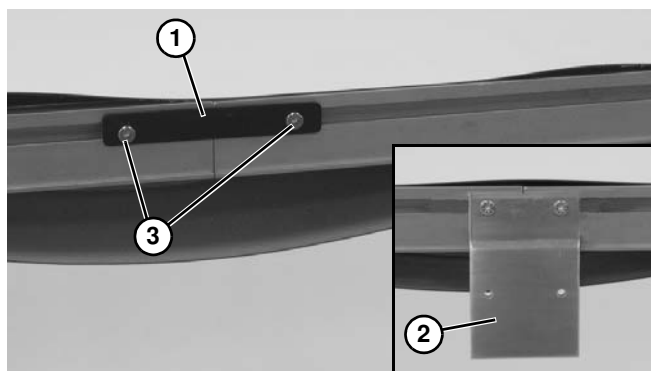

Figure 13

6. Tension conveyor belt. For proper tensioning, refer to “Conveyor Belt Tensioning” on page 22”.
7. Install mounting brackets and return rollers. Refer to “Mounting Brackets” on page 11 and “Return Rollers” on page 12.
8. If equipped with cam tracking assemblies, reposition and adjust belt tracking. Refer to “Conveyor Belt Tracking” on page 23.

Mounting Brackets

1. Locate brackets. Exploded views shown in Figure 14.

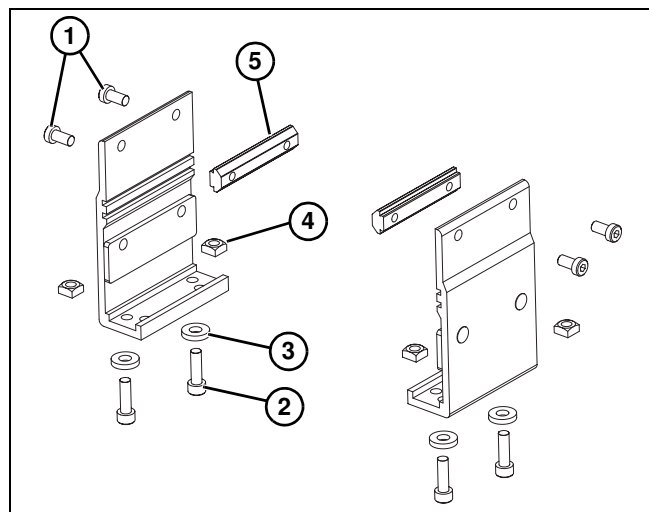

Figure 14

2. Remove screws (**Figure 14, item 1 & 2**), washers (**Figure 14, item 3**), nuts (**Figure 14, item 4**), and tee bars (**Figure 14, item 5**) from brackets.
3. Insert tee bars (**Figure 15, item 1**) into conveyor side slots (**Figure 15, item 2**).

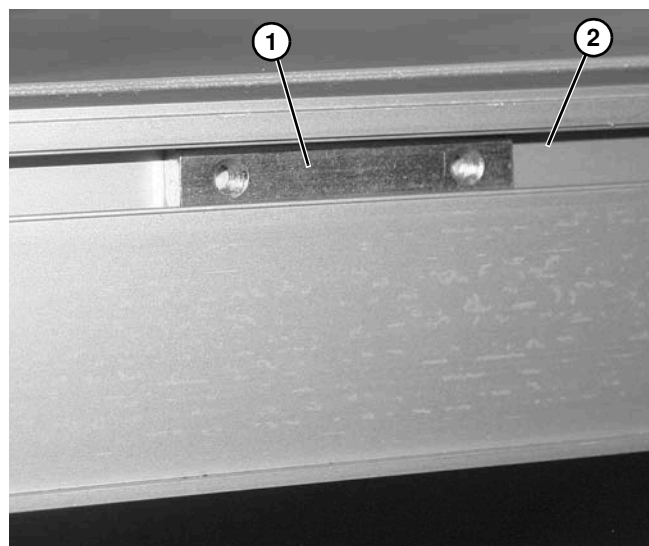

Figure 15

Installation

4. Install mounting bracket (**Figure 16, item 1**) onto conveyor frame, with frame plate (**Figure 16, item 2**) resting on bottom of conveyor frame (**Figure 16, item 3**). Fasten brackets onto tee bars (**Figure 16, item 4**) in conveyor frame with mounting screws (**Figure 16, item 5**).

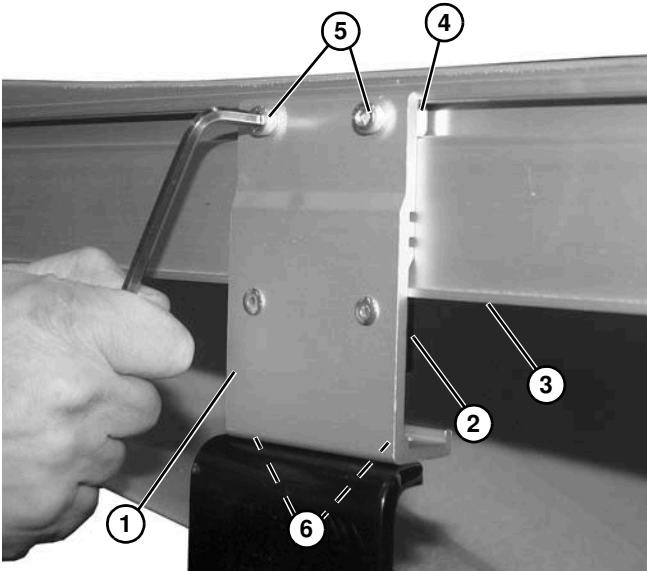

Figure 16

5. Fasten brackets to support stand with mounting screws (**Figure 16, item 6**), washers (**Figure 14, item 3**) and nuts (**Figure 14, item 4**).
6. Tighten all screws to 60 in-lb (7 Nm).

Return Rollers

1. Locate return rollers. Exploded view shown in Figure 17.

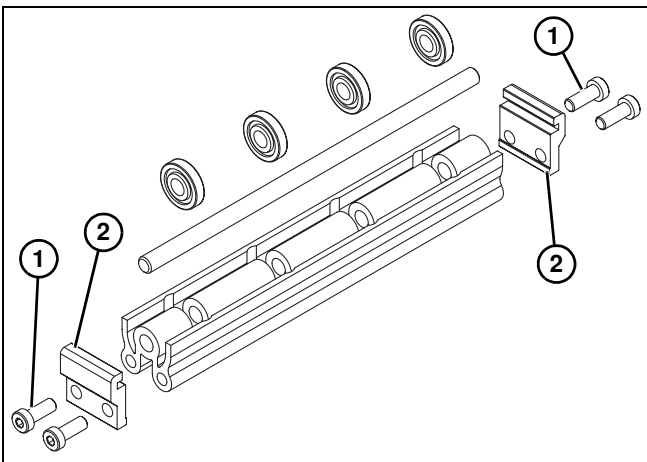

Figure 17

2. Remove screws (**Figure 17, item 1**) and clips (**Figure 17, item 2**) from roller assembly.

3. Install roller assembly as shown (**Figure 18, item 1**). Tighten screws (**Figure 18, item 2**) to 60 in-lb (7 Nm).

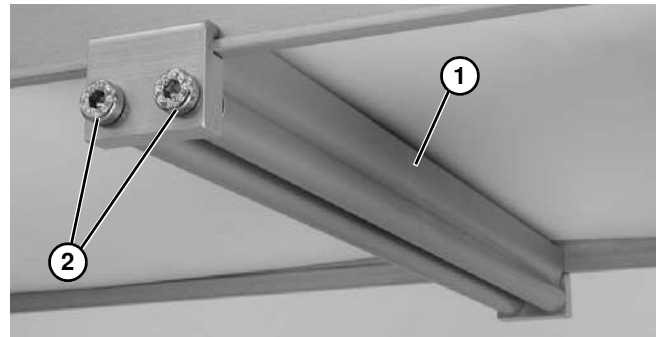

Figure 18

iDrive Controller

⚠ WARNING



Exposed moving parts can cause severe injury. **LOCK OUT POWER** before removing guards or performing maintenance.

Assembly

⚠ WARNING



Motor may start immediately once power is supplied. Exposed moving parts can cause severe injury. **LOCK OUT POWER** before wiring to avoid accidental startup.

1. Attach end (**Figure 19, item 1**) of motor wiring to threaded end (**Figure 19, item 2**) on controller.

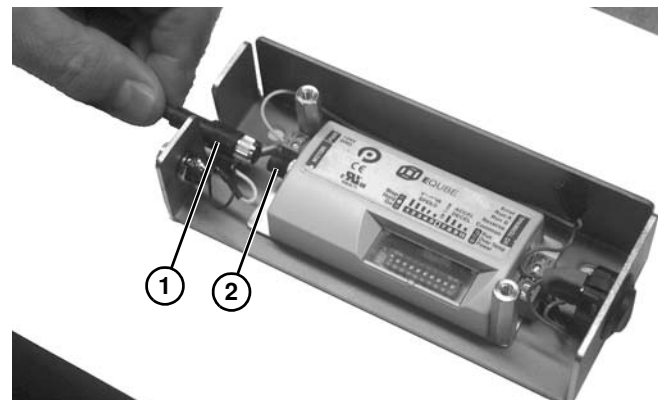

Figure 19

Installation

2. Insert tee bar (**Figure 20, item 1**) into conveyor side slot (**Figure 20, item 2**).

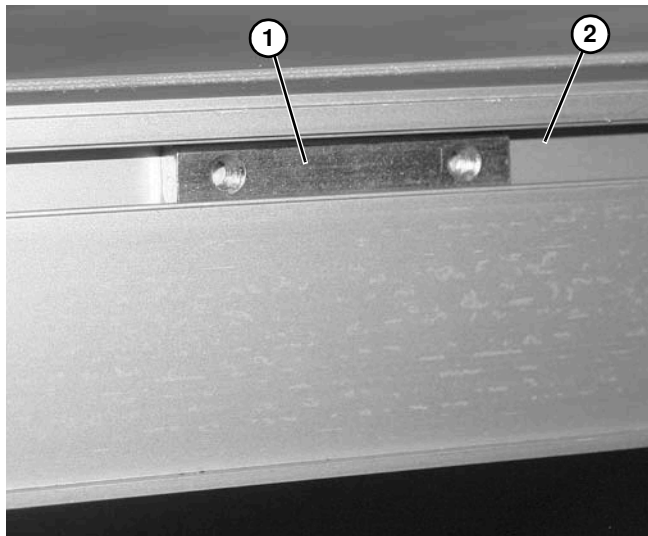

Figure 20

3. Secure mounting bracket (**Figure 21, item 1**) with two screws (**Figure 21, item 2**).

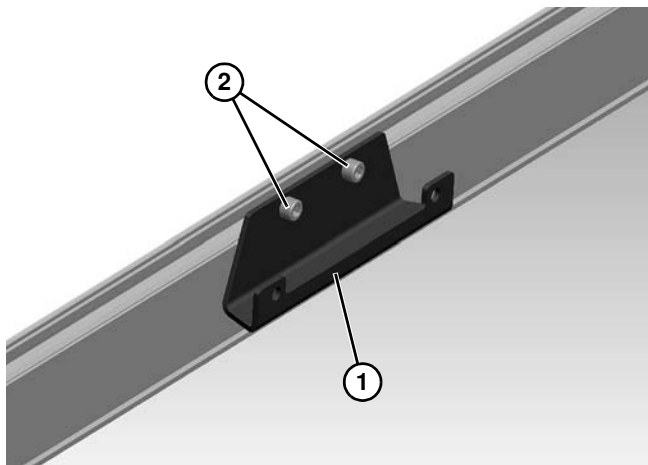

Figure 21

4. Secure controller assembly (**Figure 22, item 1**) onto mounting bracket (**Figure 21, item 1**) with two screws (**Figure 22, item 2**) and nuts (**Figure 22, item 3**).

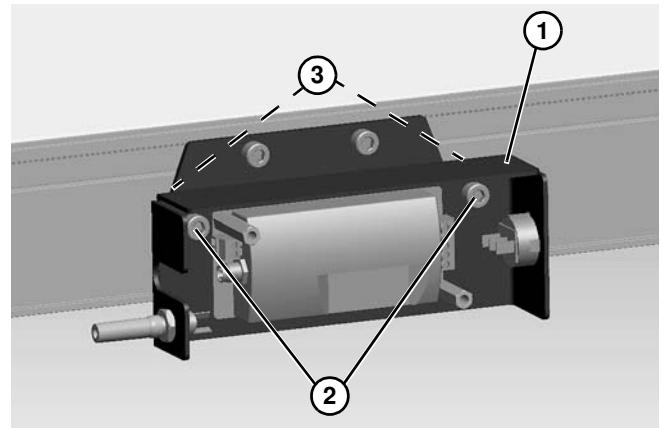

Figure 22

5. Install cover (**Figure 23, item 1**) with two screws (**Figure 23, item 2**).

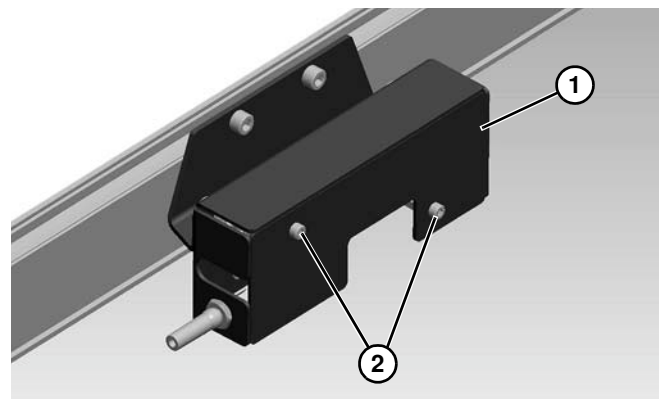

Figure 23

Installation

Setup

NOTE

1. *Start Stop Application: Maximum start stop cycles are 30 per minute.*
2. *Reversing Applications: Do not reverse the motor direction when running. Make sure the motor is stopped before reversing signal is given.*

1. Conveyor speed is controlled by DIP switch settings. Use the single motor chart below to determine your maximum speed.

Motor	Speed Range
G	1 to 10.4 M/min (3.3 to 34 ft/min)
F	1.5 to 15.4 M/min (4.9 to 51 ft/min)
E	2.1 to 21.1 M/min (6.9 to 69 ft/min)
D	2.6 to 25.7 M/min (8.5 to 84 ft/min)
C	3.8 to 37.9 M/min (12.5 to 124 ft/min)
B	4.5 to 45 M/min (14.7 to 147 ft/min)
A	6.1 to 61 M/min (20.1 to 201 ft/min)

2. To set the conveyor maximum speed, use the DIP switch settings shown.

- Speed: DIP Switches 1-5 (**Figure 24, item 1**). and switch settings chart **Figure 25**).

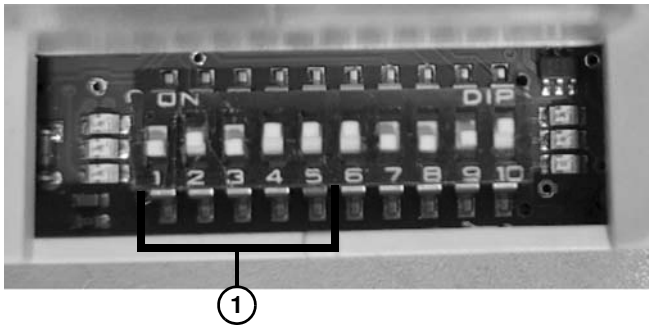

Figure 24

Switch 1	Switch 2	Switch 3	Switch 4	Switch 5	Frequency	Motor RPM	% of Max. Speed
Off	Off	Off	Off	Off	49	580	10.0%
Off	Off	Off	Off	On	67	800	14.0%
Off	Off	Off	On	Off	84	1000	17.0%
Off	Off	Off	On	On	100	1200	20.5%
Off	Off	On	Off	Off	117	1400	24.0%
Off	Off	On	Off	On	134	1600	27.5%
Off	Off	On	On	Off	150	1800	31.0%
Off	Off	On	On	On	167	2000	34.5%
Off	On	Off	Off	Off	184	2200	38.0%
Off	On	Off	Off	On	200	2400	41.5%
Off	On	Off	On	Off	217	2600	45.0%
Off	On	Off	On	On	234	2800	48.5%
Off	On	On	Off	Off	280	3000	51.5%
Off	On	On	Off	On	267	3200	55.0%
Off	On	On	On	Off	284	3400	58.5%
Off	On	On	On	On	300	3600	62.0%
On	Off	Off	Off	Off	317	3800	65.5%
On	Off	Off	Off	On	334	4000	69.0%
On	Off	Off	On	Off	350	4200	72.5%
On	Off	Off	On	On	367	4400	76.0%
On	Off	On	Off	Off	384	4600	79.5%
On	Off	On	Off	On	400	4800	83.0%
On	Off	On	On	Off	409	4900	84.5%
On	Off	On	On	On	417	5000	86.0%
On	On	Off	Off	Off	425	5100	88.0%
On	On	Off	Off	On	434	5200	89.5%
On	On	Off	On	Off	442	5300	91.5%
On	On	Off	On	On	450	5400	93.0%
On	On	On	Off	Off	459	5500	95.0%
On	On	On	Off	On	467	5600	96.5%
On	On	On	On	Off	475	5700	98.5%
On	On	On	On	On	484	5800	100.0%

Figure 25

- Direction: DIP Switch 6 (**Figure 26, item 1**), and switch settings chart **Figure 27**).

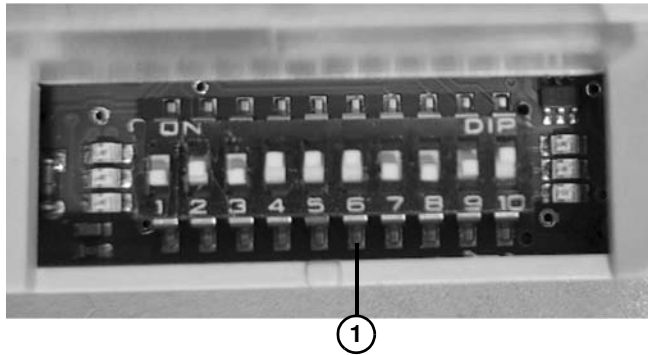

Figure 26

Switch	Function	Off	On
6	Direction of Rotation	CW	CCW

Figure 27

- Acceleration/Deceleration: DIP Switches 7-10 (**Figure 28, item 1**), and switch settings chart **Figure 29**).

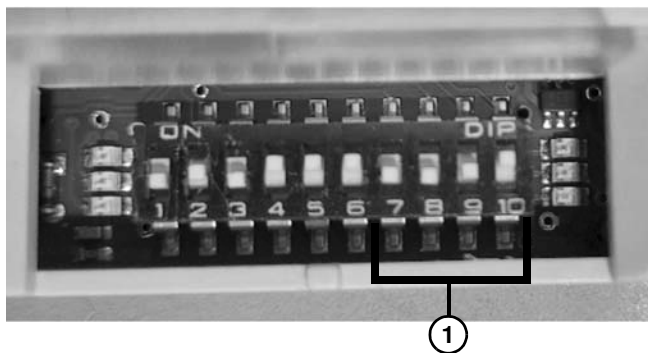

Figure 28

Switch 7	Switch 8	Switch 9	Switch 10	Accel/Decel Time (sec)
Off	Off	Off	Off	0.050
Off	Off	Off	On	0.100
Off	Off	On	Off	0.500
Off	Off	On	On	0.300
Off	On	Off	Off	0.400
Off	On	Off	On	0.500
Off	On	On	Off	0.600
Off	On	On	On	0.700
On	Off	Off	Off	.0.800
On	Off	Off	On	1.000
On	Off	On	Off	1.200
On	Off	On	On	1.400
On	On	Off	Off	1.600
On	On	Off	On	1.800
On	On	On	Off	2.000
On	On	On	On	2.500

Figure 29

- The toggle switch (**Figure 30, item 1**) on the side of the controller provides additional controls.



Figure 30

- **Position I** = half of the set speed
- **Position O** = off
- **Position II** = full set speed

Installation

- For remote controls, a cord grip (**Figure 31, item 1**) is provided to accommodate 4.3 - 11.4 mm (0.17 - 0.45") diameter cords.

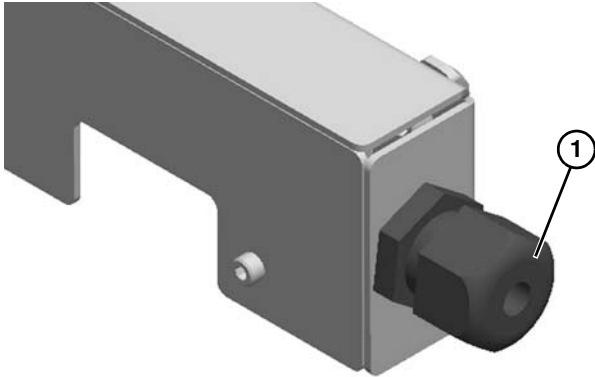

Figure 31

- Wiring diagram **Figure 32**:



Figure 32

Guide Clips

- Install guide clip assembly (**Figure 33, item 1**) into conveyor t-slot (**Figure 33, item 2**) as shown.

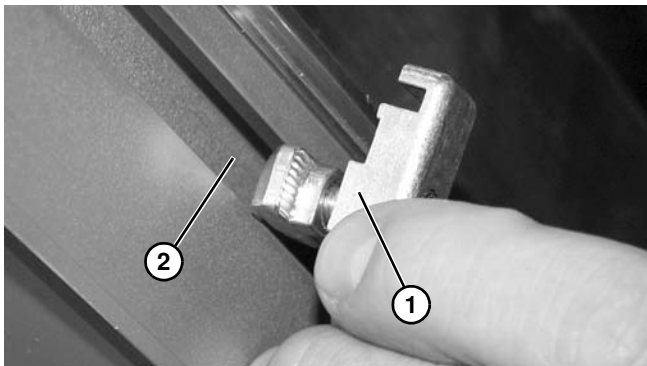

Figure 33

- Tighten screw (**Figure 34, item 1**) making sure t-nut (**Figure 34, item 2**) rotates and engages inside of t-slot.

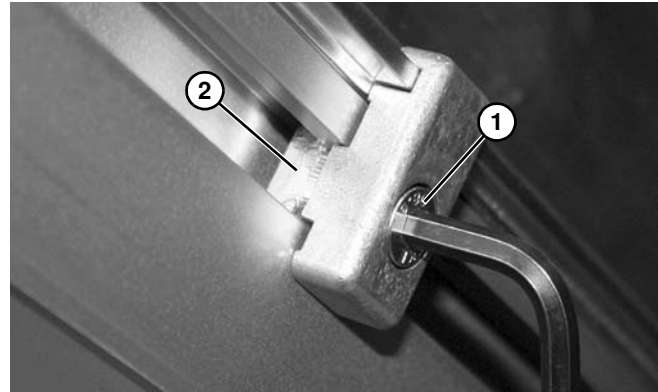

Figure 34

Adjustable Guides

- Install guide bracket assembly (**Figure 35, item 1**) into the conveyor t-slot (**Figure 35, item 2**).

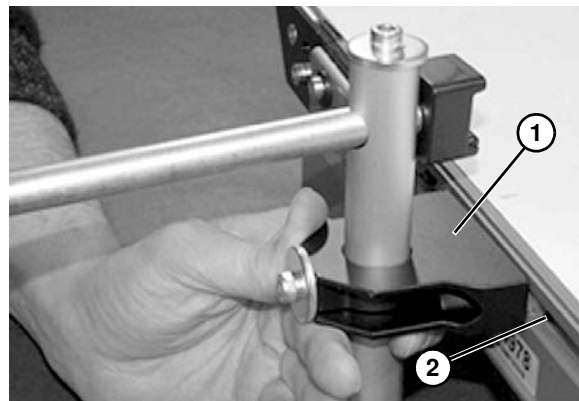

Figure 35

- Tighten screws (**Figure 36, item 1**) making sure t-nut (**Figure 36, item 2**) rotates and engages inside of the t-slot.



Figure 36

Installation

3. Loosen screw (**Figure 37, item 1**) on end of shaft (**Figure 37, item 2**) to remove clip (**Figure 38, item 1**).

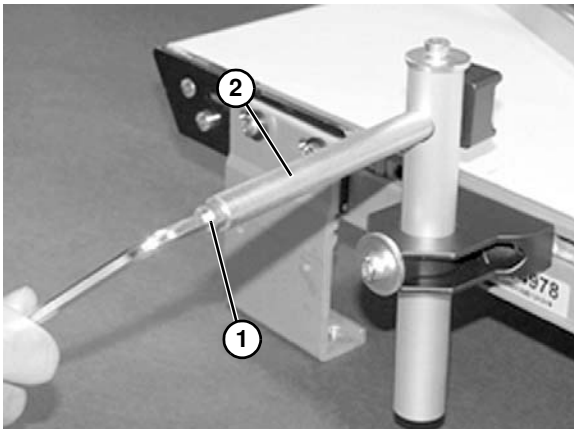

Figure 37

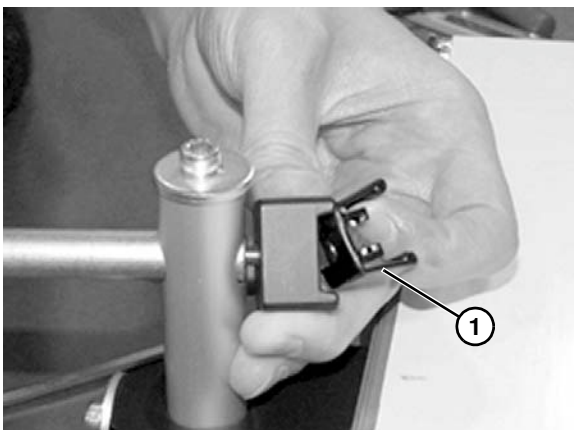

Figure 38

4. Snap clip (**Figure 39, item 1**) onto guide rail (**Figure 39, item 2**).

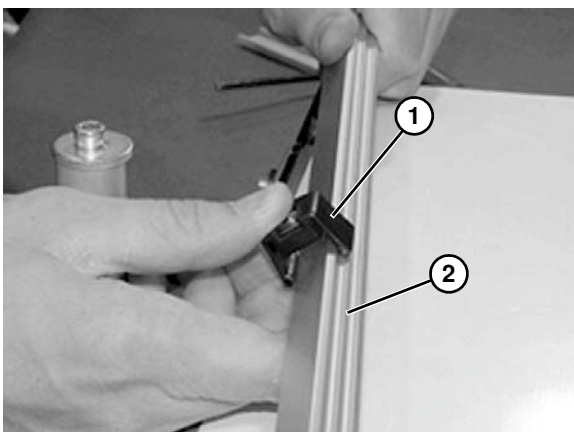

Figure 39

5. Reassemble clip (**Figure 40, item 1**) and attach to shaft (**Figure 40, item 2**). Tighten screw (**Figure 37, item 1**) on end of shaft.

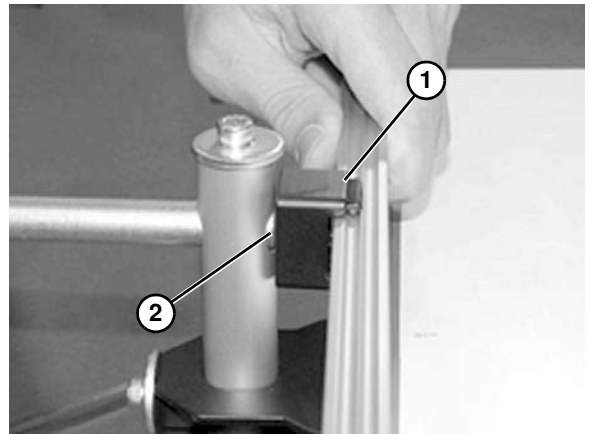

Figure 40

6. Adjust rail width with top screw (**Figure 41, item 1**).

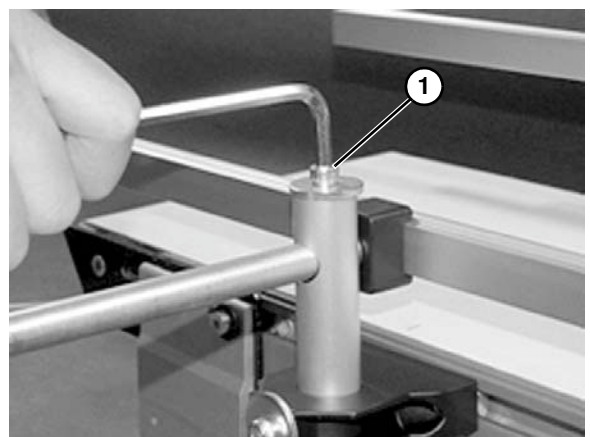

Figure 41

7. Adjust rail height with lower screw (**Figure 42, item 1**).

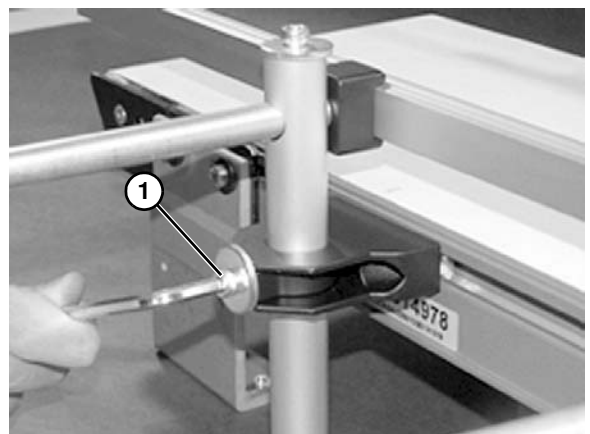

Figure 42

Preventive Maintenance and Adjustment

Required Tools

Standard Tools

- Hex-key wrenches:
 - 2.5 mm, 3mm, 4 mm, 5 mm
- Heavy-Duty Screwdriver

Checklist

- Keep service parts on hand (see “Service Parts” section for recommendations)
- Keep supply of belt cleaner
- Clean entire conveyor and knurled pulley while disassembled
- Replace worn or damaged parts

Lubrication

No lubrication is required. Replace bearings if worn.

Maintaining Conveyor Belt

Troubleshooting

Inspect conveyor belt for:

- Surface cuts or wear
- Stalling or slipping
- Damage to V-guide

Surface cuts and wear indicate:

- Sharp or heavy parts impacting belt
- Jammed parts
- Improperly installed bottom wipers (if installed)
- Accumulated dirt in wipers (if installed)
- Foreign material inside the conveyor
- Improperly positioned accessories
- Bolt-on guiding is pinching belt

Stalling or slipping indicates:

- Excessive load on belt
- Conveyor belt or drive timing belt are not properly tensioned
- Worn knurl or impacted dirt on drive pulley
- Intermittent jamming or drive train problems

Damage to V-guide indicates:

- Twisted or damaged conveyor frame
- Dirt impacted on pulleys
- Excessive or improper side loading

Cleaning

Use mild soap and water. Do not soak the belt.

For /05 woven polyester and /06 black anti-static belts, use a bristled brush to improve cleaning.

Conveyor Belt Replacement

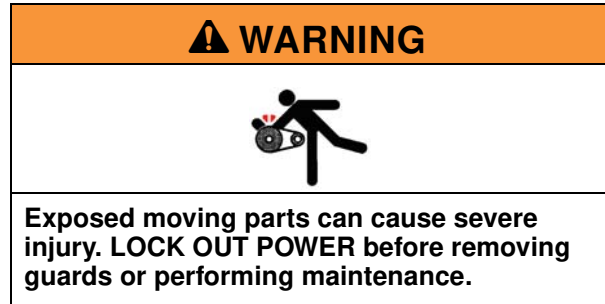

Conveyor Belt Replacement Sequence

- Release tension
- Remove old conveyor belt:
 - Conveyor without Stands or Gearmotor Mounting Package
 - Conveyor with Stands and Gearmotor Mounting Package
- Install new conveyor belt
- Tension conveyor belt

Preventive Maintenance and Adjustment

Belt Removal for End Drive and iDrive Conveyors

⚠ WARNING



Removing mounting brackets without support under gearmotor will cause conveyor to tip, causing severe injury. PROVIDE SUPPORT UNDERNEATH THE GEARMOTOR WHEN CHANGING THE BELT.

1. Place temporary support stands (**Figure 43, item 1**) at both ends of the conveyor. Place an additional support stand (**Figure 43, item 2**) under the drive motor, if equipped. See WARNING.

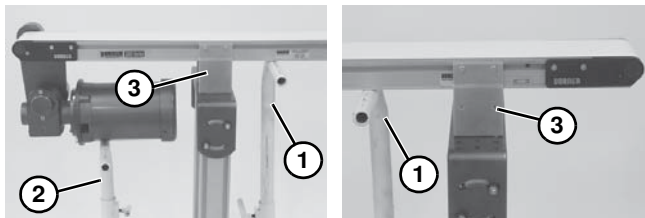

Figure 43

2. If equipped, remove mounting brackets (**Figure 43, item 3**) from one side of conveyor. (Reverse steps 3 & 4 of “Mounting Brackets” section beginning on page 11.) If equipped with heavy load drive package, remove brackets from side opposite drive cover (**Figure 44, item 1**).
3. If equipped, remove return rollers and guiding and accessories from side opposite drive cover (**Figure 44, item 1**).

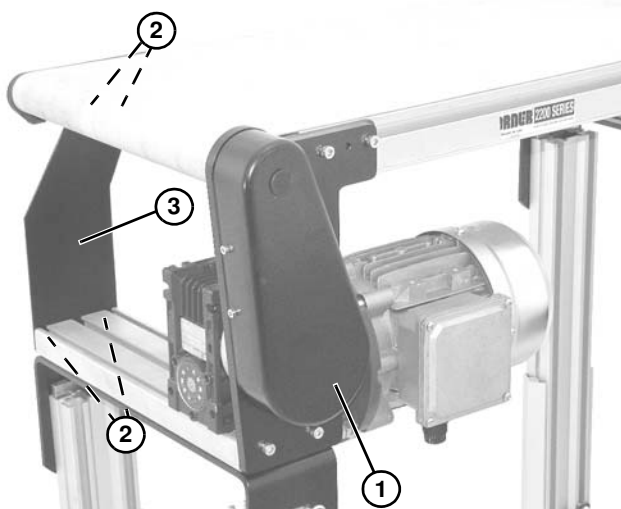



Figure 44

4. If equipped with heavy load drive package, remove bracket screws (**Figure 44, item 2**) and drive support bracket (**Figure 44, item 3**).
5. Follow the corresponding instructions below:

a. Idler Tail

b. End Drive Tail

c. iDrive Tail

- a. On idler end of conveyor, identified with a  label (**Figure 45, item 1**), push in head plate assembly (**Figure 45, item 2**):

- On both sides of conveyor, loosen and move cam tracking assemblies (**Figure 45, item 3**) (if equipped) away from head plates.

- Loosen fastening screws (**Figure 45, item 4**) and push head plate assembly inward.

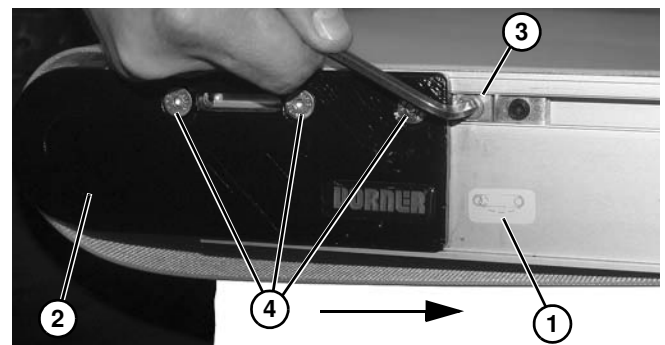

Figure 45

- b. On end drive of the conveyor, push in head plate assembly (**Figure 46, item 1**):

- On both sides of conveyor, loosen fastening screws (**Figure 46, item 2**).

- On both sides of conveyor, rotate cam tracking assemblies (**Figure 46, item 3**) to move head plate assembly inward.

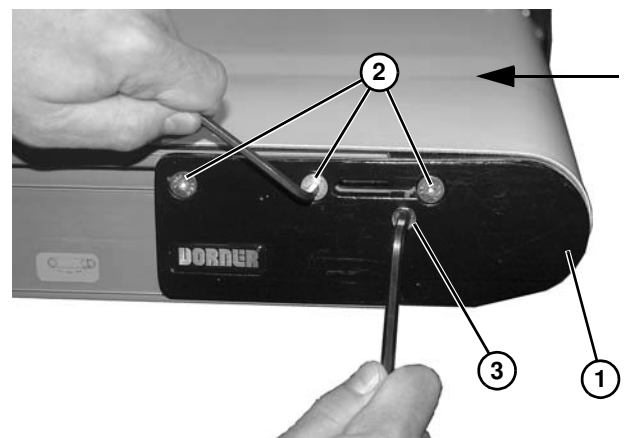

Figure 46

Preventive Maintenance and Adjustment

- c. On iDrive end of the conveyor, push in head plate assembly (Figure 47, item 1):

NOTE

To prevent damage to the head plates and spindle, be sure to remove them slowly because they are not attached to spindle.

- Remove middle screw (Figure 47, item 2) from iDrive head plate (Figure 47, item 1) on each side of conveyor.

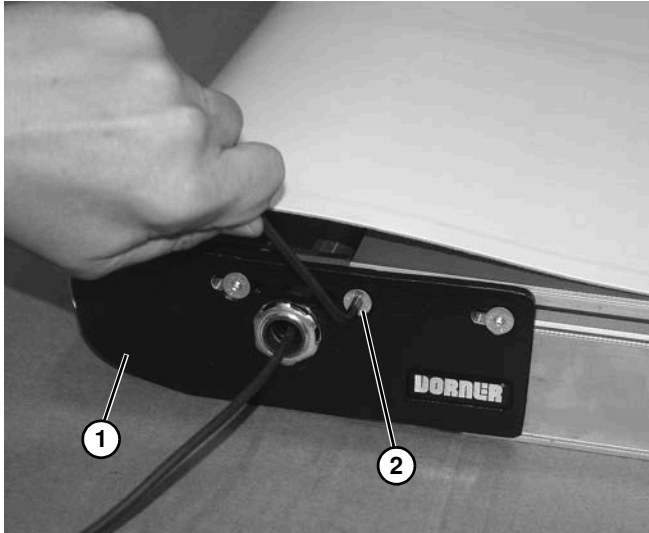

Figure 47

- Loosen outer fastening screws (Figure 48, item 1) from iDrive head plate (Figure 48, item 2) (on each side of conveyor) to allow head plate assembly to slide in slots (Figure 48, item 3). Push head plate inward toward conveyor.

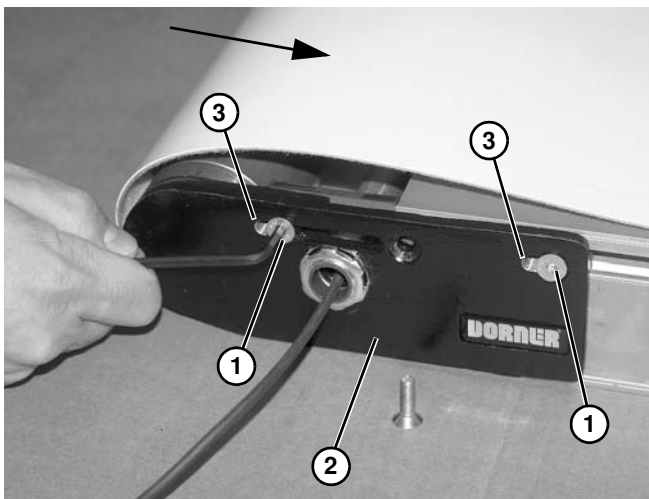

Figure 48

6. Remove belt (Figure 49, item 1) from conveyor.



Figure 49

Belt Removal for Mid Drive Conveyors

⚠ WARNING



SEVERE HAZARD!

LOCK OUT POWER before removing guards or performing maintenance. Exposed moving parts can cause serious injury.

1. Remove belt tension. See “Conveyor Belt Replacement” on page 18 for releasing belt tension.
2. Remove two screws (Figure 50, item 1) from bottom of mid drive assembly (Figure 50, item 2) on each side.

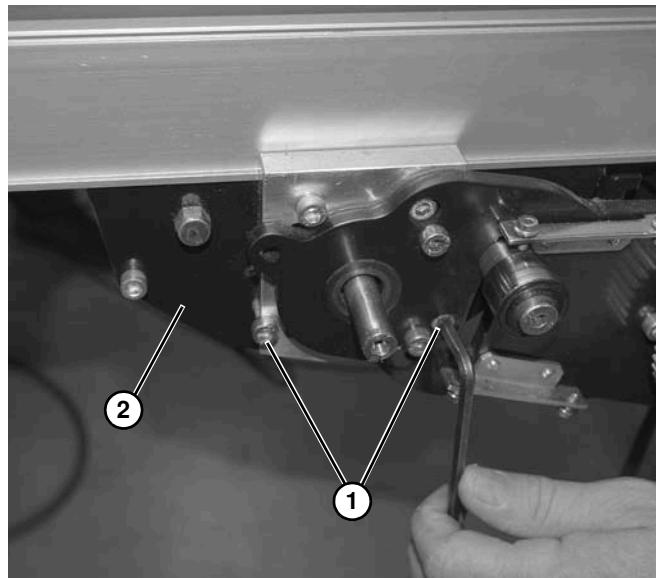

Figure 50

Preventive Maintenance and Adjustment

- Lower and remove mid drive module (**Figure 51, item 1**) from belt (**Figure 51, item 2**).

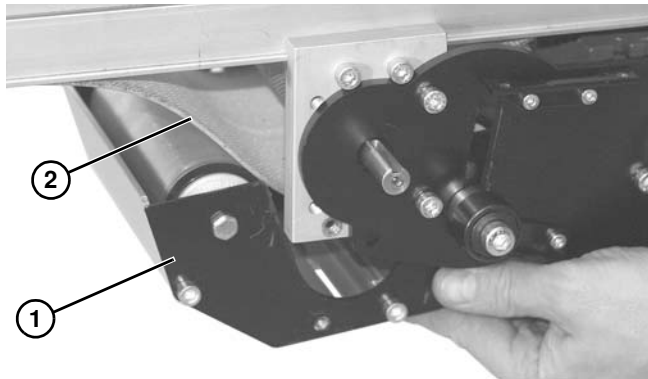

Figure 51

- Remove belt (**Figure 52, item 1**) from conveyor frame.



Figure 52

- Installation of new belt is the reverse order of removal.

Belt Installation for End Drive and iDrive Conveyors

⚠ WARNING
<p>Removing mounting brackets without support under gearmotor will cause conveyor to tip, causing severe injury. PROVIDE SUPPORT UNDERNEATH THE GEARMOTOR WHEN CHANGING THE BELT.</p>

- Ensure temporary support stands (**Figure 53, item 1**) are placed at both ends of the conveyor. Place an additional support stand under the drive motor (**Figure 53, item 2**), if equipped. See WARNING.

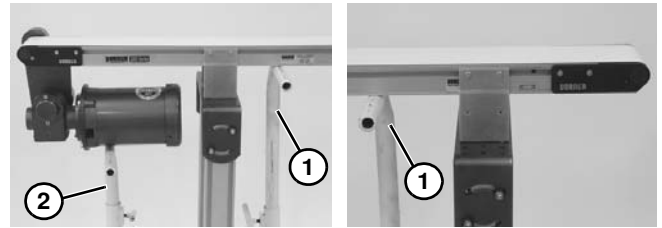

Figure 53

- Orient belt so splice outer fingers (**Figure 54, item 1**) point in the direction of belt travel as identified by the conveyor directional label (**Figure 54, item 2**).

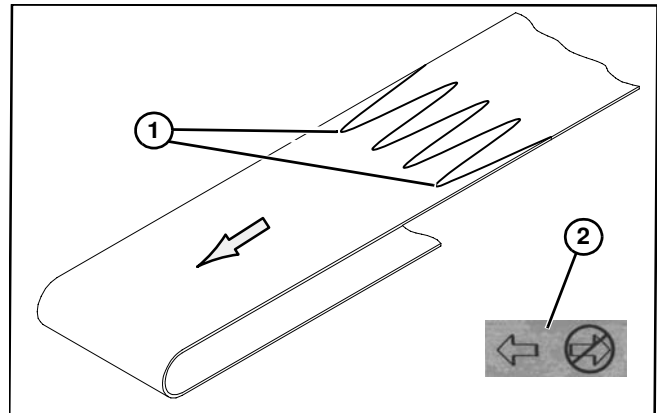

Figure 54

NOTE

Verify V-Guide on belt (**Figure 55, item 1**), is aligned with V-Guide in frame (**Figure 55, item 2**) and tails (**Figure 55, item 3**).

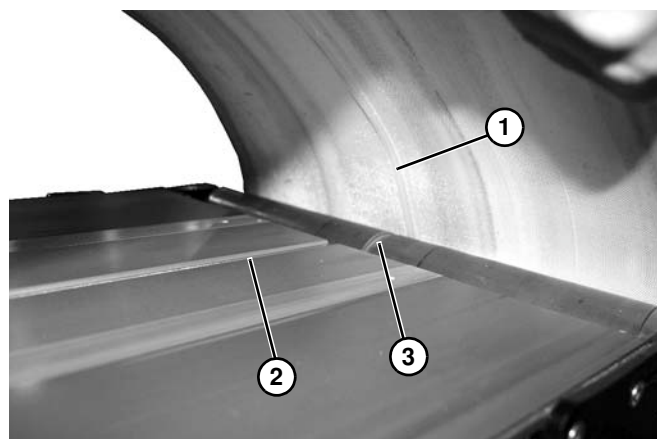

Figure 55

Preventive Maintenance and Adjustment

3. Install belt (**Figure 56, item 1**) on conveyor. Lift conveyor slightly to avoid pinching belt on temporary support stands.



Figure 56

4. Re-install conveyor mounting brackets. Refer to “Mounting Brackets” beginning on page 11, steps 3 through 5.
5. If equipped with a heavy load drive package, install drive support bracket (**Figure 57, item 1**).

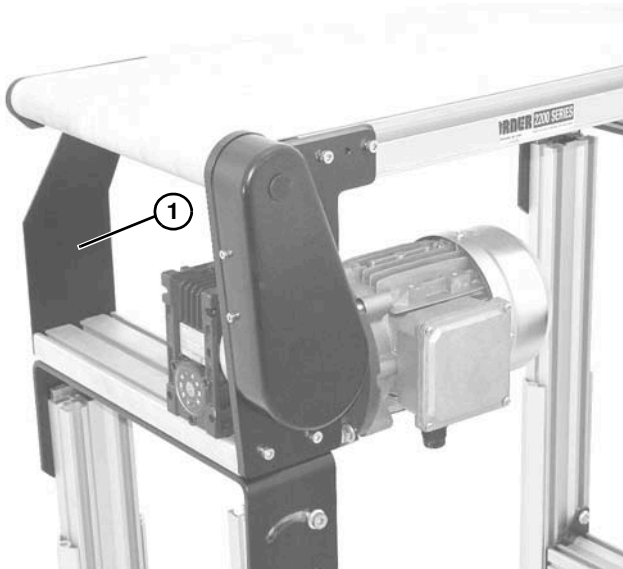



Figure 57

6. Tension belt. Refer to “Conveyor Belt Tensioning” on page 22.
7. If equipped, install return rollers and guiding.

Conveyor Belt Tensioning

⚠ WARNING
<p>Exposed moving parts can cause severe injury. LOCK OUT POWER before removing guards or performing maintenance.</p>

1. For standard end drive conveyors, on fixed end of the conveyor, identified with  a label (**Figure 58, item 1**), adjust head plate assembly (**Figure 58, item 2**):
 - a. On both sides of conveyor, loosen fastening screws (**Figure 58, item 3**).
 - b. On both sides of conveyor, rotate cam tracking assemblies (**Figure 58, item 4**) all the way to move head plates out.

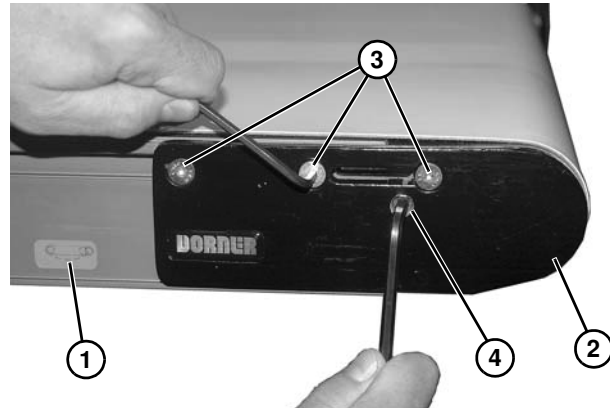



Figure 58

2. For standard end drive conveyors, on tension end of the conveyor, identified with  a label (**Figure 59, item 1**), adjust head plate assembly (**Figure 59, item 2**):
 - a. On both sides of conveyor, loosen fastening screws (**Figure 59, item 3**).
 - b. On both sides of conveyor, adjust cam tracking assemblies (**Figure 59, item 4**) (if equipped) to adjust head plate assembly.

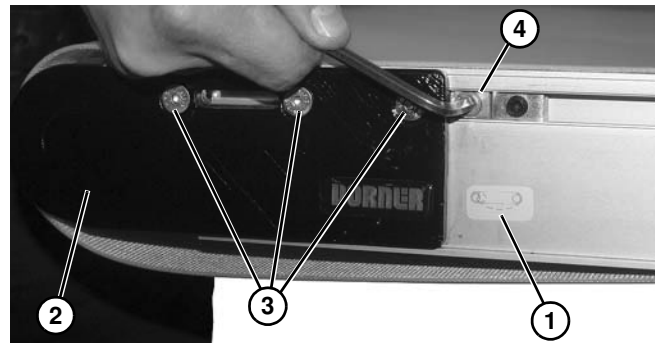

Figure 59

Preventive Maintenance and Adjustment

- Adjust head plate assembly so end of conveyor frame aligns with or between the head plate tensioning marks (**Figure 60, item 1 & 2**). Replace belt if proper tensioning can not be obtained while aligning the end of the conveyor frame with or between the tensioning marks.

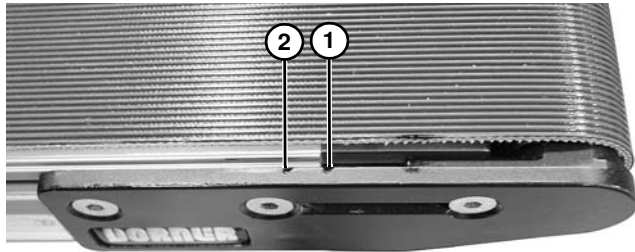

Figure 60

NOTE

On pinion gear, do not exceed a torque of 25 in-lb (2.8 Nm) for 8 – 12" (203 – 305 mm) wide conveyors and 50 in-lb (4.5 Nm) for a 14 – 36" (356 – 914 mm) wide conveyor. Over tensioning the conveyor belt could cause excessive pulley bearing load and early failure.

- After adjusting proper tensioning, tighten fastening screws (**Figure 58, item 3**) or (**Figure 59, item 3**) on both sides of conveyor to 60 in-lb (7 Nm).

Conveyor Belt Tracking

V-Guided Belts

V-guided belts do not require tracking adjustment.

Non V-Guided Belts

Non V-guided belt conveyors are equipped with belt tracking cam assemblies (**Figure 61, item 1**) for belt tracking adjustment.

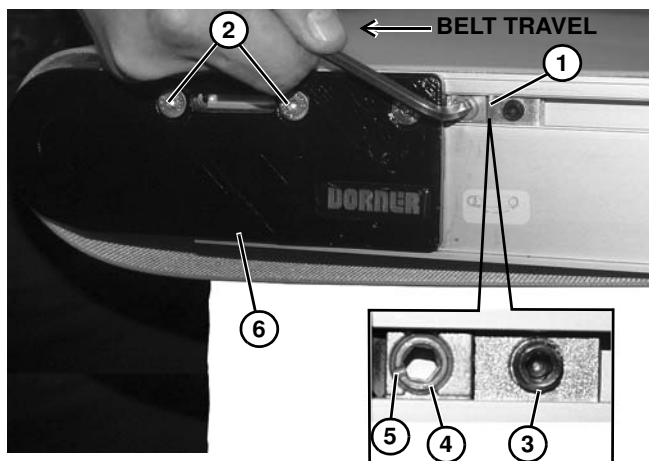

Figure 61

When adjusting belt tracking, always adjust the discharge end of the conveyor first. To adjust belt tracking:

- Ensure head plate fastening screws (**Figure 61, item 2**) on both sides of conveyor are tightened.
- On both sides of conveyor, loosen cam fastening screw (**Figure 61, item 3**). Adjust cams (**Figure 61, item 4**) until indicator slots (**Figure 61, item 5**) are horizontal and facing end of conveyor. Then slide cam assemblies against head plates (**Figure 61, item 6**) and re-tighten cam fastening screws (**Figure 61, item 3**) to 60 in-lb (7 Nm).
- On the side toward which the belt is tracking, loosen head plate fastening screws (**Figure 61, item 2**).
- With the conveyor running, use a 5 mm hex-key wrench to rotate the tracking cam (**Figure 61, item 4**) in small increments until the belt tracks in the center of the conveyor. Then while holding the cam in position, re-tighten the head plate fastening screws (**Figure 61, item 2**) with a 4 mm hex-key wrench to 60 in-lb (7 Nm).

End Drive Conveyor Belts

End drive conveyors are equipped with internal belt cam assemblies for belt tracking adjustment on motor end.

When adjusting belt tracking, always adjust the discharge end of the conveyor first. To adjust belt tracking:

- On the side opposite which the belt is tracking, loosen head plate fastening screws (**Figure 62, item 1**).

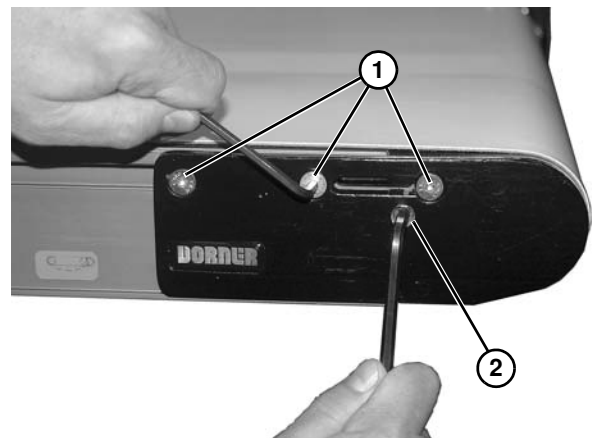

Figure 62

- With the conveyor running, use a hex-key wrench to rotate the tracking cam (**Figure 62, item 2**) to retract tail in small increments until the belt tracks in the center of the conveyor. Then while holding the cam in position, re-tighten the head plate fastening screws (**Figure 62, item 1**) to 60 in-lb (7 Nm).

Preventive Maintenance and Adjustment

Pulley Replacement

⚠ WARNING



Exposed moving parts can cause severe injury. LOCK OUT POWER before removing guards or performing maintenance.

Unless instructed otherwise, leave belt in place to remove the desired pulley. Follow the corresponding instructions below:

- A – Drive Pulley Removal
- B – iDrive Pulley Removal
- C – Idler Pulley Removal
- D – 5/8" Nosebar Pulley Removal
- E – Mid Drive Module Pulley Removal

A – Drive Pulley Removal

1. Remove drive package. See your appropriate Drive Package manual for removal procedure.
2. Remove belt tension.
3. Remove three fastening screws (Figure 63, item 1).

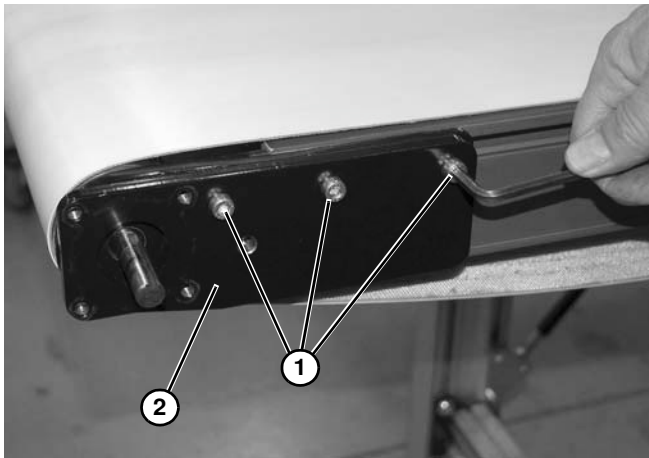

Figure 63

4. Remove the gearmotor mounting plate (Figure 63, item 2) from the conveyor frame

NOTE

To prevent damage to the head plates, be sure to remove them slowly because they are not attached to pulley.

⚠ WARNING



Drive shaft keyway may be sharp. HANDLE WITH CARE.

5. Remove the head plate (Figure 64, item 1) from the conveyor frame, holding spindle in place.



Figure 64

6. Slide the drive pulley (Figure 65, item 1) out of the belt loop.

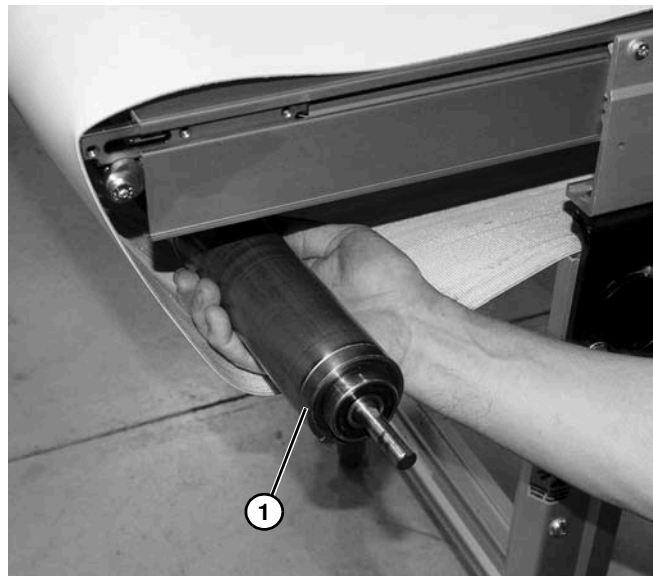

Figure 65

7. To replace the drive tail pulley, reverse the removal procedure.

Preventive Maintenance and Adjustment

NOTE

Verify V-Guide on belt (**Figure 66, item 1**), is aligned with V-Guide in frame (**Figure 66, item 2**) and tails (**Figure 66, item 3**).

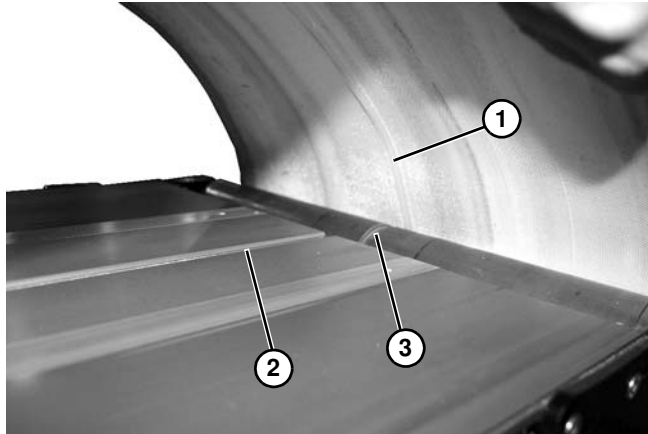

Figure 66

8. Re-install belt on end of conveyor, then tension the belt. See “Conveyor Belt Tensioning” on page 22.
9. If installed, re-position the cam assemblies against the head plates and adjust belt tracking. See “Conveyor Belt Tracking” on page 23.

B – iDrive Pulley Removal

1. Disconnect quick disconnect end (**Figure 67, item 1**) of power supply from power jack (**Figure 67, item 2**).

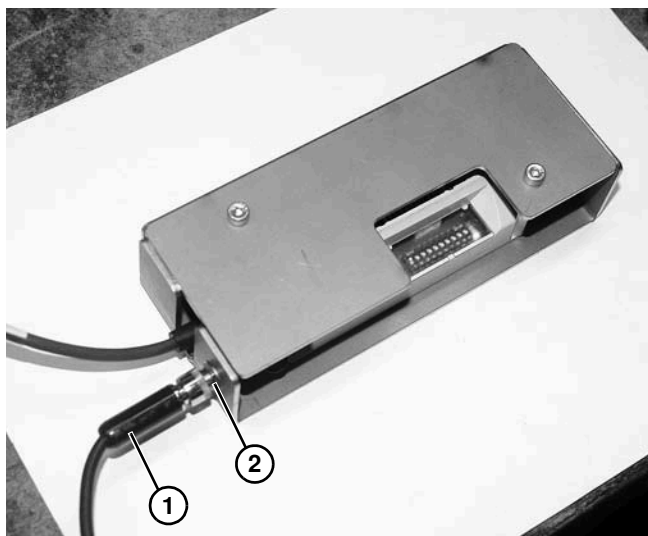

Figure 67

NOTE

To prevent damage to the head plates and spindle, be sure to remove them slowly because they are not attached to spindle.

2. Remove middle screw (**Figure 68, item 1**) from idrive head plate (**Figure 68, item 2**) on each side of conveyor.

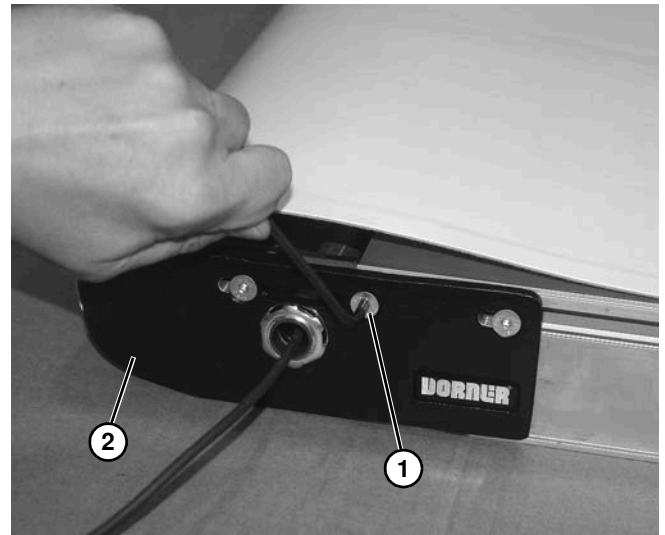

Figure 68

3. Loosen screws (**Figure 69, item 1**) from idrive head plate (**Figure 69, item 2**) (on each side of conveyor) to allow head plate assembly to slide in slots (**Figure 69, item 3**). Push head plate inward toward conveyor.

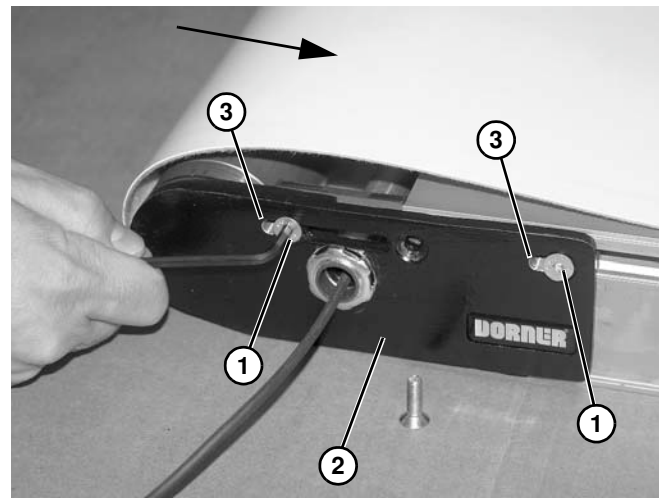

Figure 69

4. Remove belt. (Refer to “Belt Removal for End Drive and iDrive Conveyors” on page 19.)

Preventive Maintenance and Adjustment

5. Remove drive end assembly (**Figure 70, item 1**) from slots (**Figure 70, item 2**) on conveyor frame.

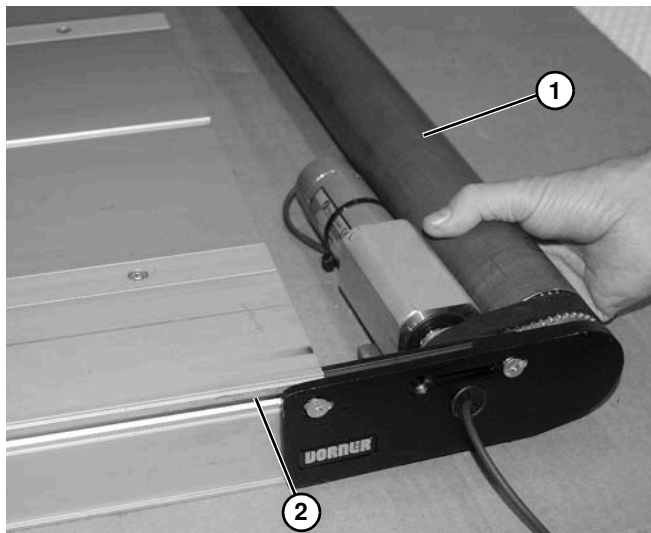

Figure 70

6. Remove two head plate fastening screws (**Figure 71, item 1**) securing head plate (**Figure 71, item 2**) onto drive end assembly.

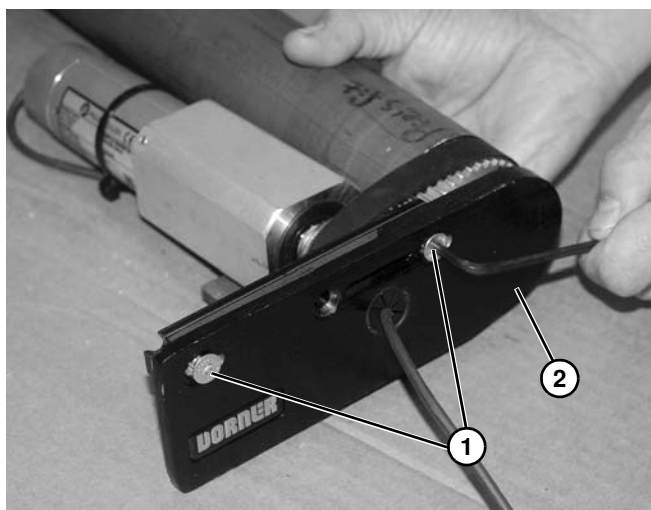

Figure 71

7. Remove end plate (**Figure 72, item 1**) from motor mounting bracket and bearing (**Figure 72, item 2**).

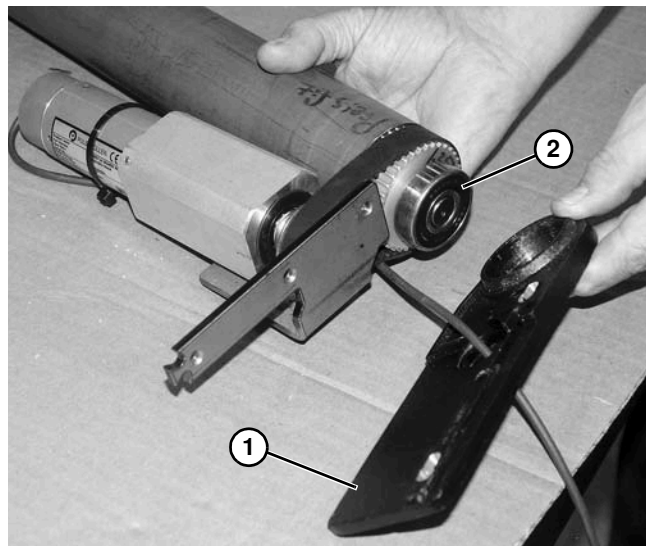

Figure 72

8. Remove pulley (**Figure 73, item 1**) off of timing belt (**Figure 73, item 2**). Replace pulley.

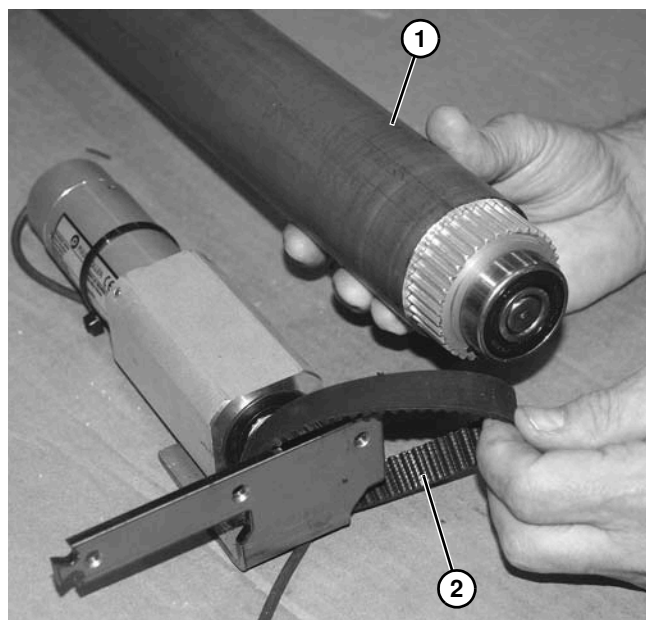

Figure 73

9. Re-install in the reverse order of removal.
10. Re-install belt on end of conveyor, then tension the belt. See "Conveyor Belt Tensioning" on page 22.
11. If installed, re-position the cam assemblies against the head plates and adjust belt tracking. See "Conveyor Belt Tracking" on page 23.

Preventive Maintenance and Adjustment

C – Idler Pulley Removal

1. Remove belt tension.
2. Remove three fastening screws (**Figure 74, item 1**).

NOTE

To prevent damage to the head plates, be sure to remove them slowly because they are not attached to pulley.

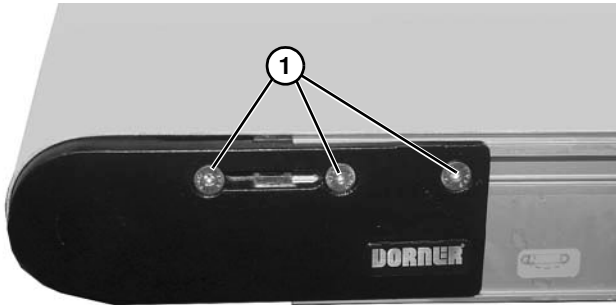

Figure 74

3. Remove the head plate (**Figure 75, item 1**) from the conveyor frame, holding spindle in place.

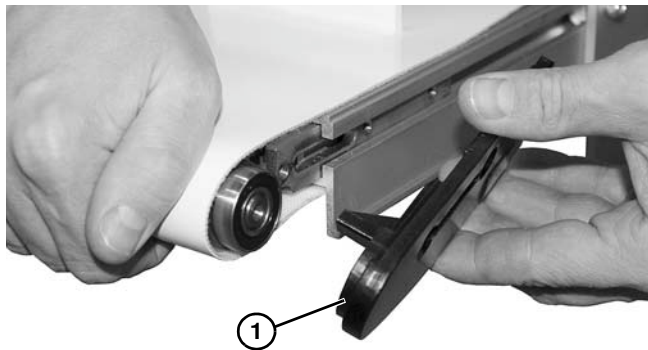

Figure 75

4. Slide spindle (**Figure 76, item 1**) out of the belt loop.



Figure 76

5. To replace the idler tail pulley, reverse the removal procedure.

NOTE

*Be certain to install idler tail pulley so that the pulley V-guide (**Figure 77, item 1**) mates with conveyor V-guide (**Figure 77, item 2**).*

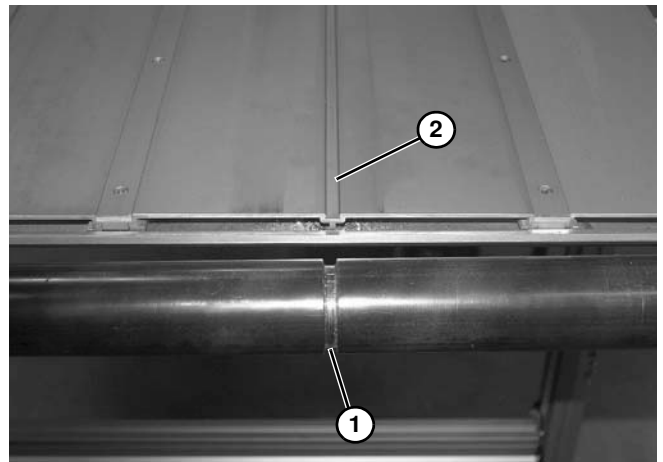

Figure 77

6. Re-install belt on end of conveyor, then tension the belt. See “Conveyor Belt Tensioning” on page 22.
7. If installed, re-position the cam assemblies against the head plates and adjust belt tracking. See “Conveyor Belt Tracking” on page 23.

Preventive Maintenance and Adjustment

D – 5/8" (16 mm) Nosebar Pulley Removal

1. On both sides of conveyor, loosen two fastening screws (**Figure 78, item 1**) to remove belt tension. Remove belt from end of conveyor. (Refer to “Belt Removal for End Drive and iDrive Conveyors” on page 19.)

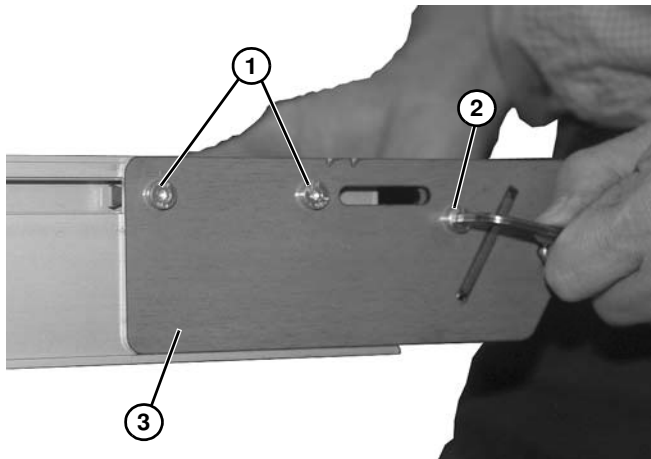

Figure 78

2. Remove two screws (**Figure 78, item 1**) and screw (**Figure 78, item 2**) from side plate (**Figure 78, item 3**).
3. Remove side plate (**Figure 79, item 1**) from nosebar tail (**Figure 79, item 2**).

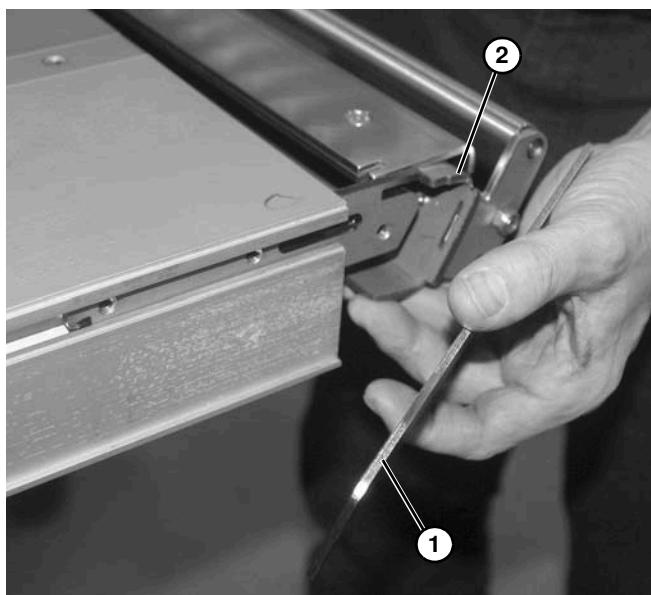

Figure 79

4. Remove nosebar tail from the conveyor and place on an open work surface. On one side of nosebar tail, remove fastening screws (**Figure 81, item 1**) from inner and outer plates (**Figure 81, item 2**).

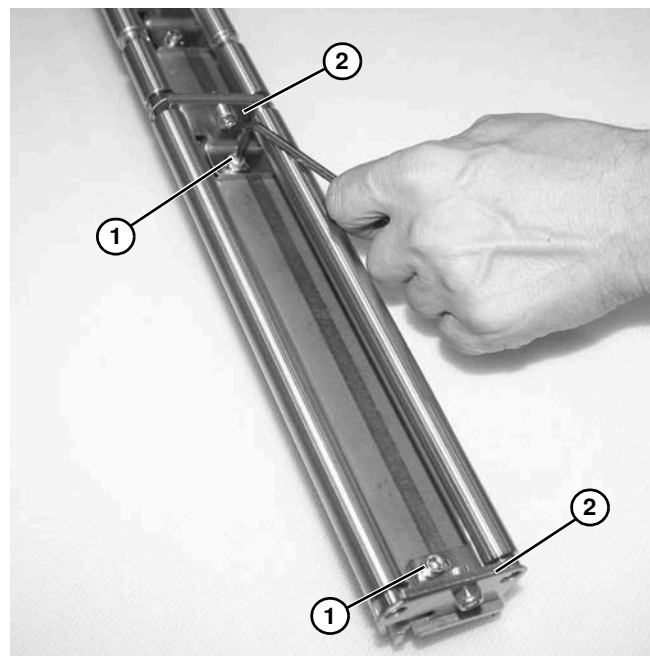

Figure 80

5. Remove outer plate (**Figure 81, item 1**) from spindles (**Figure 81, item 2**).

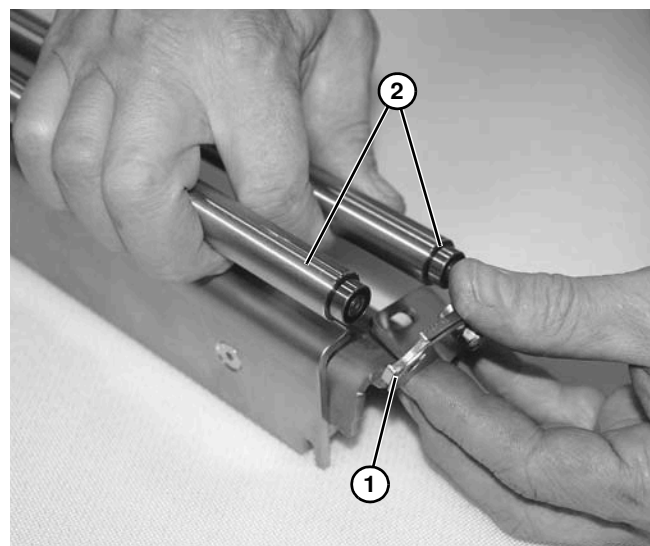

Figure 81

Preventive Maintenance and Adjustment

6. Remove spindles (**Figure 82, item 1**). Repair or replace spindles, as required.

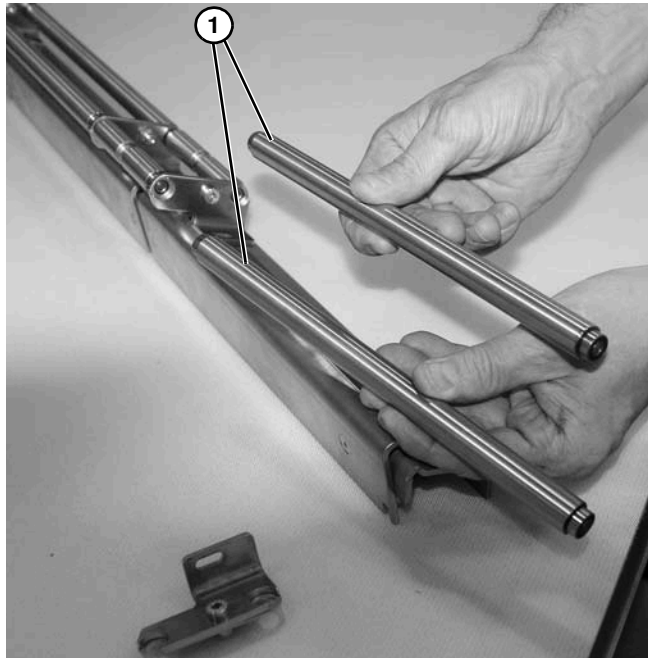

Figure 82

7. Repeat steps 4-6 for remaining spindles, as needed.

NOTE

During reassembly, make certain that the plate (**Figure 83, item 1**) is and nut (**Figure 83, item 2**) on nose bar tail (**Figure 83, item 3**) is inserted into the slot and hole in side plate (**Figure 83, item 4**).

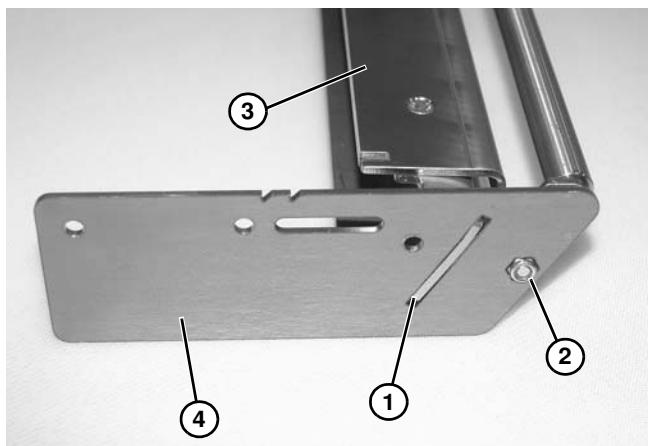

Figure 83

8. Assemble and install head plate in reverse order of removal.

NOTE

Before installing belt, verify that nosebar tail pulleys (**Figure 84, item 3**) are level with the conveyor bed (**Figure 84, item 4**).

9. To adjust nose bar pulleys to the correct height, loosen screw (**Figure 84, item 1**) on each bracket (**Figure 84, item 2**), and adjust so that rollers (**Figure 84, item 3**) are level with conveyor bed (**Figure 84, item 4**). Tighten screws when level.

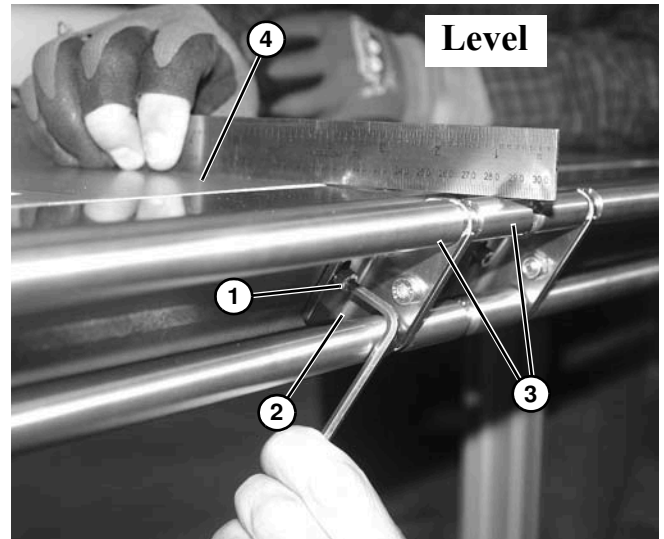

Figure 84



Figure 85

Preventive Maintenance and Adjustment

- Use a wrench to tighten lower screw (**Figure 86, item 1**) to 30 in-lb (3.4 Nm). Leave two fastening screws (**Figure 86, item 2**) loose for belt tensioning.

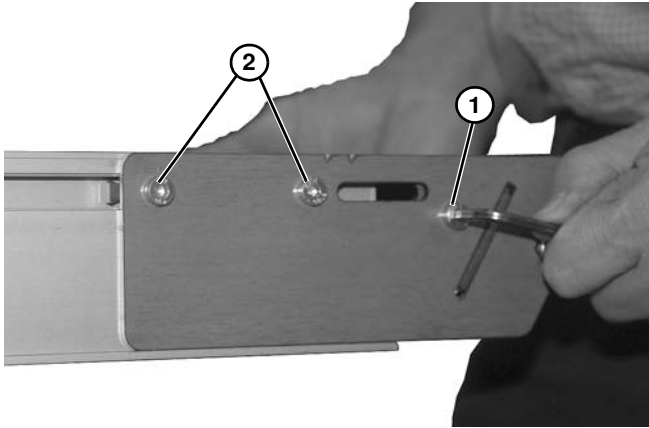
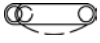

Figure 86

- Re-install belt on end of conveyor, then tension the belt. See “Conveyor Belt Tensioning” on page 22.
- Re-position the cam assemblies (if equipped) against the head plates and adjust belt tracking. See “Conveyor Belt Tracking” on page 23.

E – Mid Drive Module Pulley Removal

- On tension end of the conveyor, identified with  a label (**Figure 87, item 1**), push in head plate assembly (**Figure 87, item 2**):
 - On both sides of conveyor, loosen and move cam tracking assemblies (**Figure 87, item 3**) (if equipped) away from head plates.
 - Loosen fastening screws (**Figure 87, item 4**) and push head plate assembly inward.

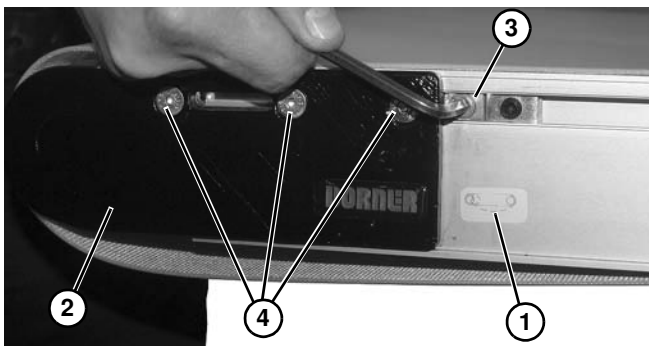

Figure 87

- Remove drive package. See your appropriate Drive Package manual for removal procedure.

- Loosen two screws (**Figure 88, item 1**) from each side of mounting block (**Figure 88, item 2**).

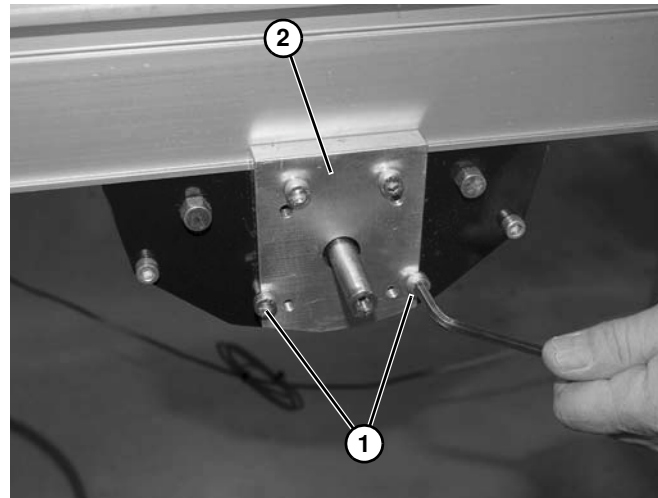

Figure 88

- Lower and remove mid drive module (**Figure 89, item 1**) from belt (**Figure 89, item 2**).

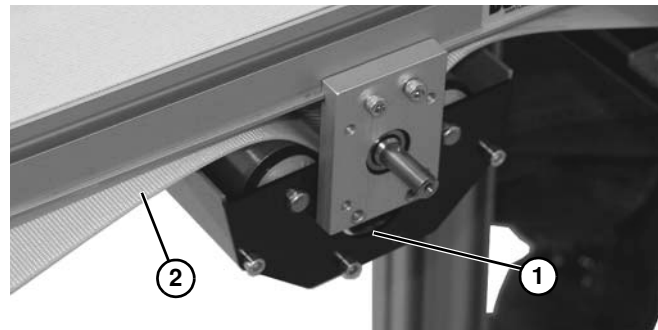

Figure 89

- Loosen two screws (**Figure 90, item 1**) from each side of mounting block (**Figure 90, item 2**).

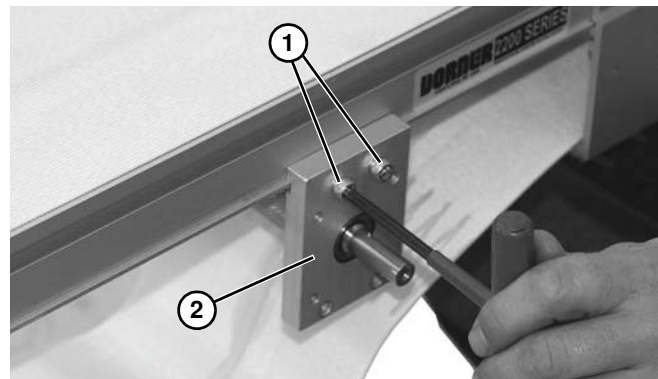

Figure 90

Preventive Maintenance and Adjustment

6. Separate mounting blocks (Figure 91, item 1) from spindle (Figure 91, item 2).

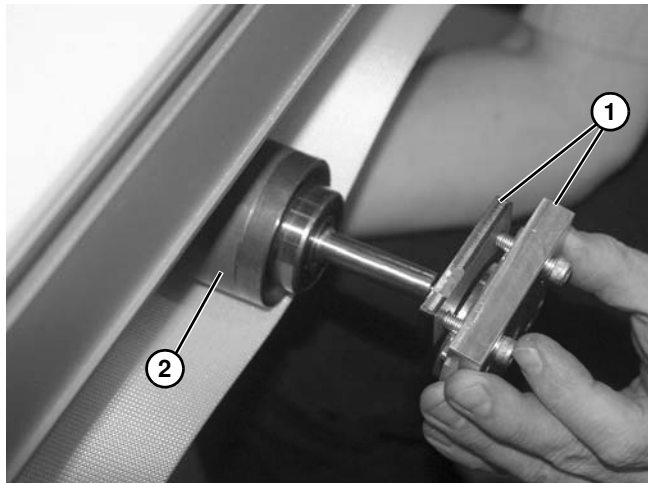

Figure 91

7. Replace spindle.
8. On mid drive module, use a heavy-duty screwdriver to push in pin (Figure 92, item 1) to release end of spindle from bracket (Figure 92, item 2). Remove and replace each spindle (Figure 93, item 1).

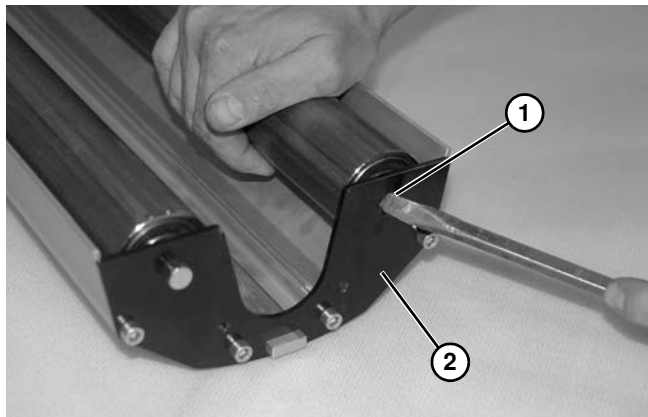

Figure 92

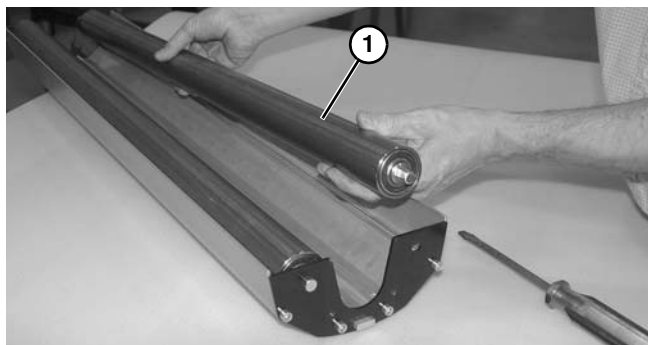

Figure 93

9. Install components, reverse order of removal.

NOTE

Before reassembly, make certain that the bar (Figure 94, item 1) rests inside slotted area (Figure 94, item 2) in each side bracket.

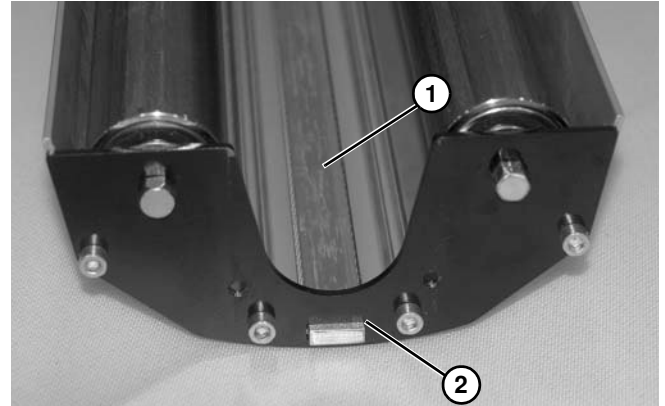

Figure 94

10. Be certain to use a square (Figure 95, item 1) across mounting blocks (Figure 95, item 2), so blocks are aligned to one another, before tightening hardware.

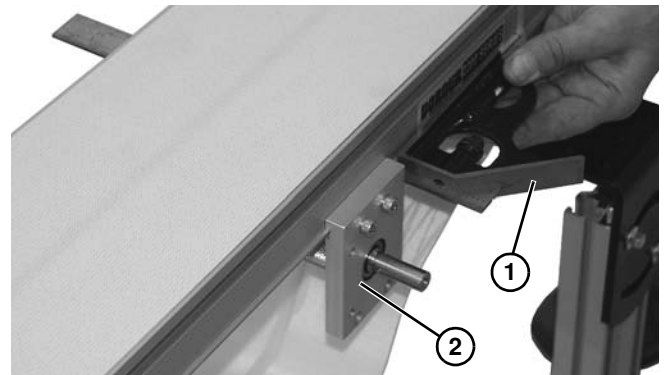

Figure 95

11. Tighten screws (Figure 88, item 1) and (Figure 90, item 1) to 60 in-lb (7 Nm).
12. Tension conveyor belt. See "Conveyor Belt Tensioning" on page 22.

Preventive Maintenance and Adjustment

iDrive Motor Replacement

1. Disconnect quick disconnect end (Figure 96, item 1) of power supply from power jack (Figure 96, item 2).

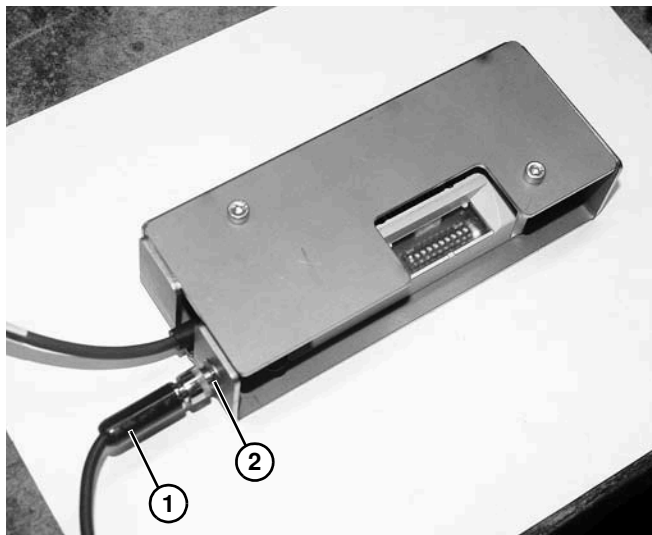

Figure 96

NOTE

To prevent damage to the head plates and spindle, be sure to remove them slowly because they are not attached to spindle.

2. Remove screw (Figure 97, item 1) from idrive head plate (Figure 97, item 2) on each side of conveyor.

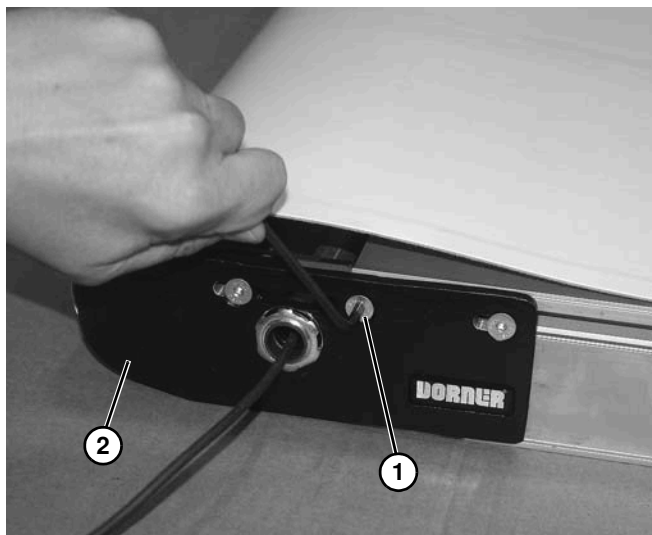

Figure 97

3. Loosen screws (Figure 98, item 1) from idrive head plate (Figure 98, item 2) on each side of conveyor. Push head plate inward toward conveyor.

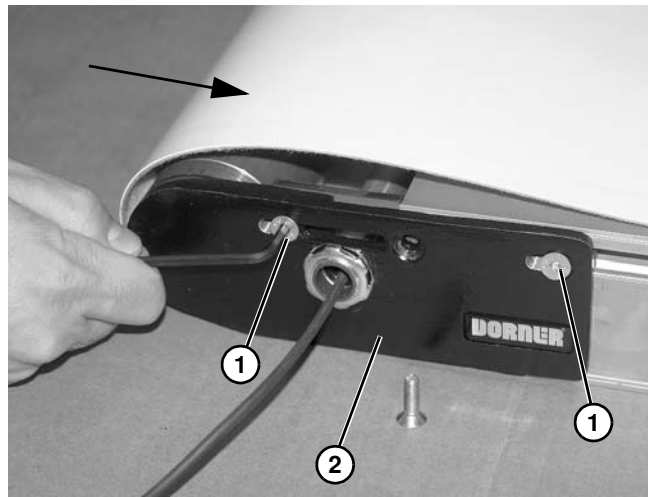

Figure 98

4. Remove belt. (Refer to “Belt Removal for End Drive and iDrive Conveyors” on page 19.)
5. Remove drive end assembly (Figure 99, item 1) from slots (Figure 99, item 2) on conveyor frame.

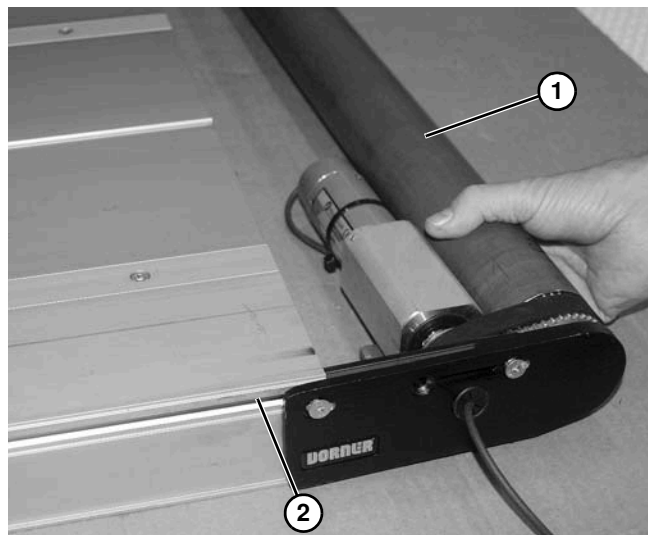

Figure 99

Preventive Maintenance and Adjustment

6. Remove two head plate fastening screws (**Figure 100, item 1**) securing head plate (**Figure 100, item 2**) onto drive end assembly.

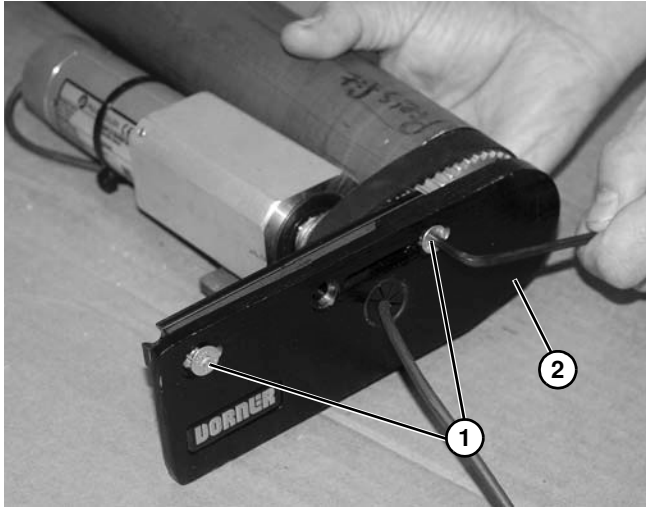

Figure 100

7. Remove end plate (**Figure 101, item 1**) from motor mounting bracket and bearing (**Figure 101, item 2**).

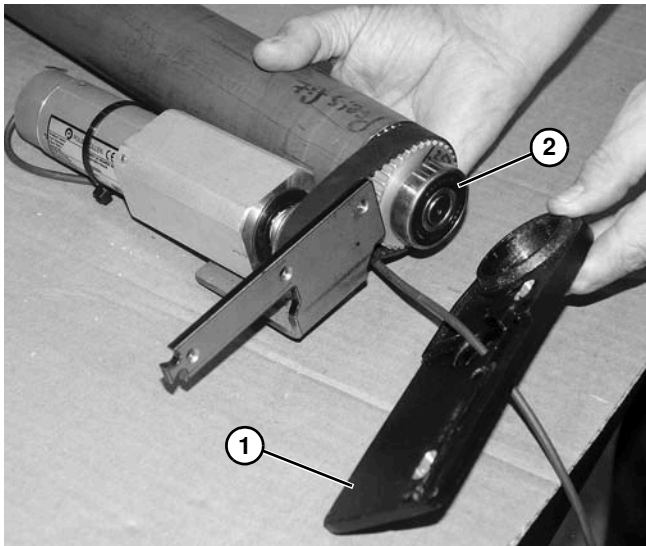

Figure 101

8. Remove pulley (**Figure 102, item 1**) off of timing belt (**Figure 102, item 2**).

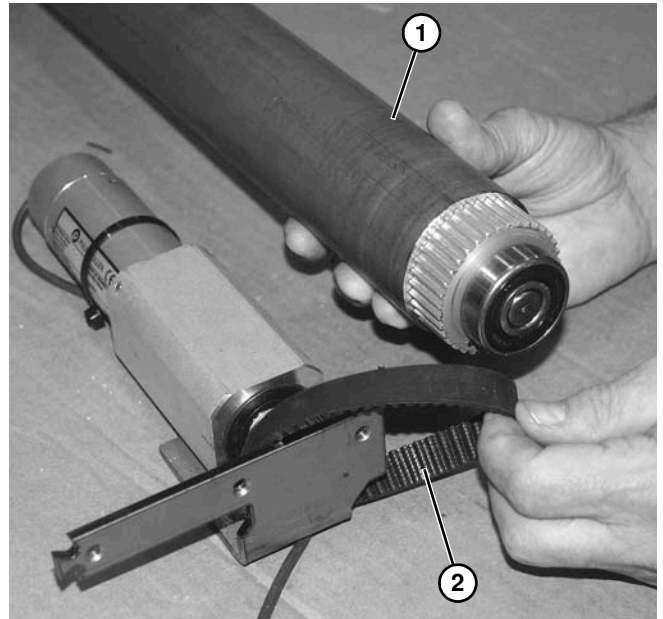

Figure 102

9. Remove four screws (**Figure 103, item 1**) securing motor (**Figure 103, item 2**) to motor mounting bracket (**Figure 102, item 3**).

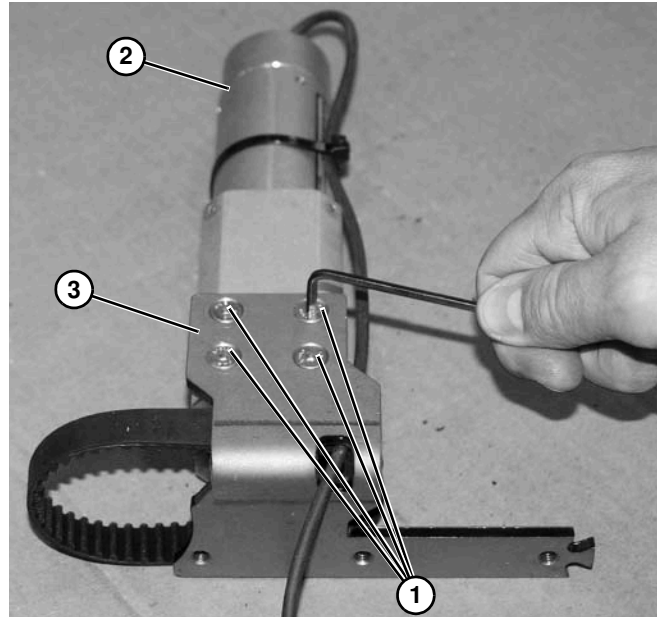

Figure 103

Preventive Maintenance and Adjustment

10. Remove motor mounting bracket (Figure 104, item 1) from motor (Figure 104, item 2).

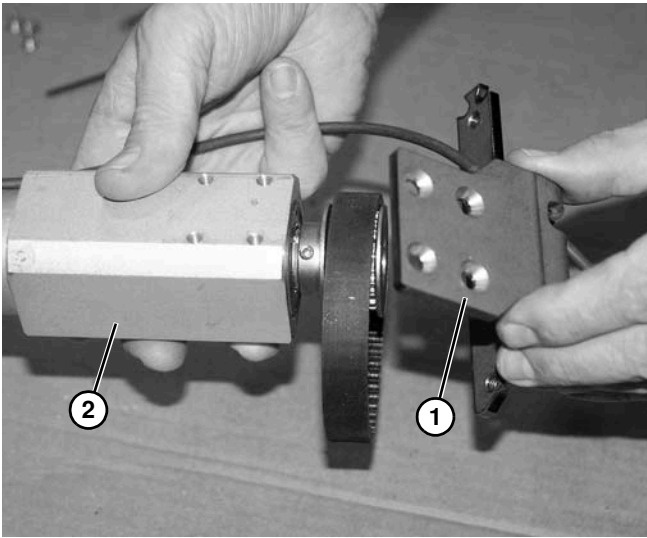

Figure 104

12. Remove and retain key (Figure 106, item 1) on motor shaft (Figure 106, item 2).

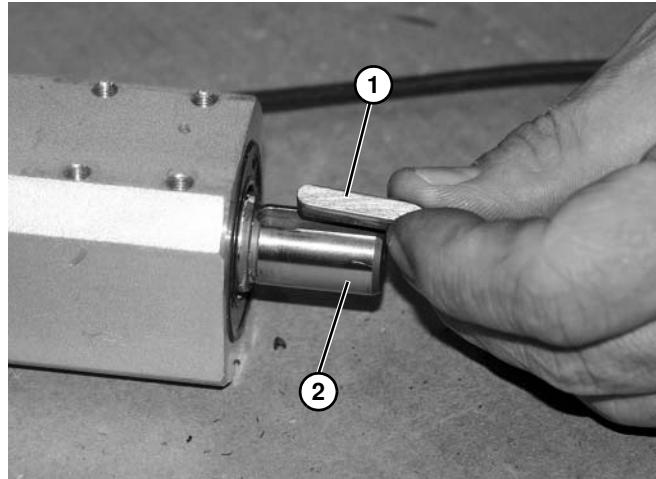

Figure 106

13. Replace motor.
14. Re-install in the reverse order of removal.
15. Re-install belt on end of conveyor, then tension the belt. See “Conveyor Belt Tensioning” on page 22.
16. If installed, re-position the cam assemblies against the head plates and adjust belt tracking. See “Conveyor Belt Tracking” on page 23.

⚠ WARNING

Drive shaft keyway may be sharp. HANDLE WITH CARE.

11. Loosen two set screws (Figure 105, item 1) securing drive pulley (Figure 105, item 2). Slide drive pulley off of motor shaft.

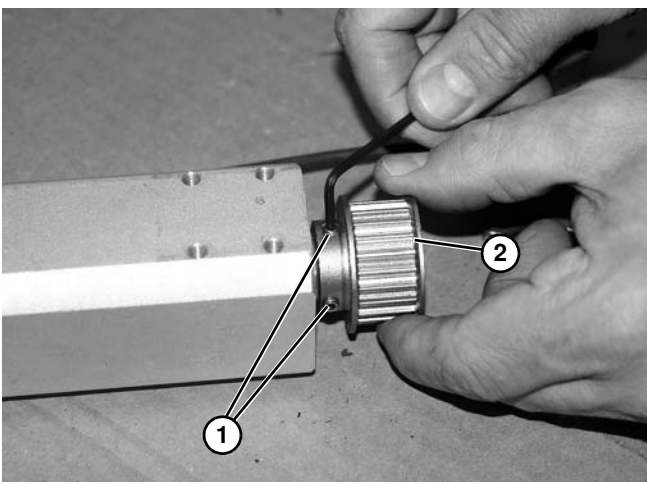

Figure 105

Pinion Replacement

1. Remove conveyor belt. See “Conveyor Belt Replacement” section on page 18.
2. Remove idler tail (Figure 107, item 1) by sliding off of the conveyor (Figure 107, item 2).

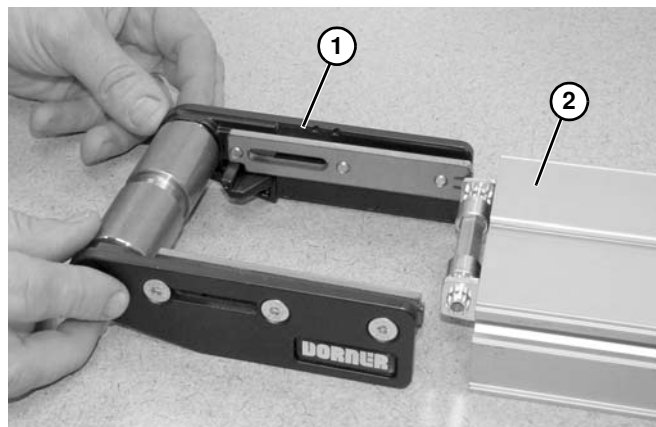

Figure 107

Preventive Maintenance and Adjustment

3. Pry pinion assembly (**Figure 108, item 1**) from conveyor frame by alternating sides.

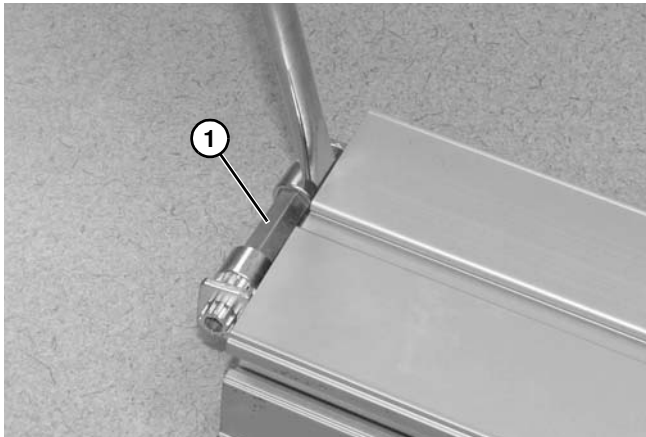

Figure 108

4. Replace worn components.

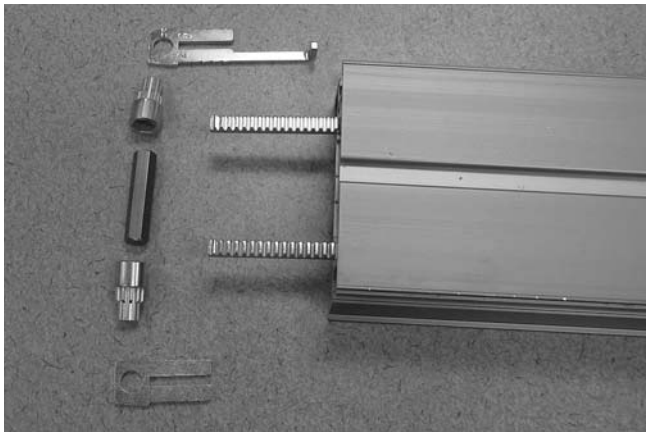

Figure 109

5. To reassemble, make sure that the lines (**Figure 110, item 1**) on the pinion end gears (**Figure 110, item 2**) are aligned.

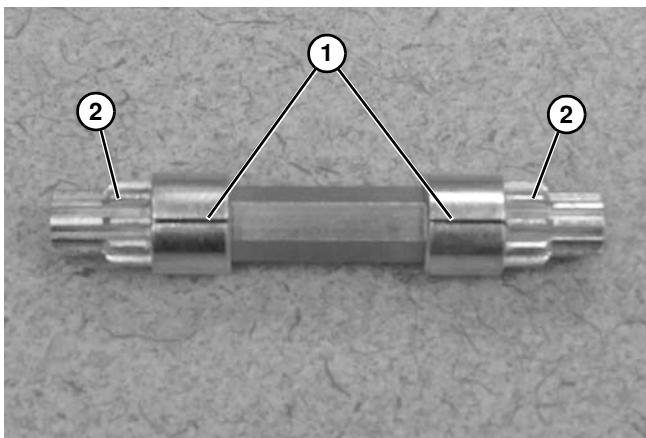

Figure 110

6. Slide on retaining plates (**Figure 111, item 1**).

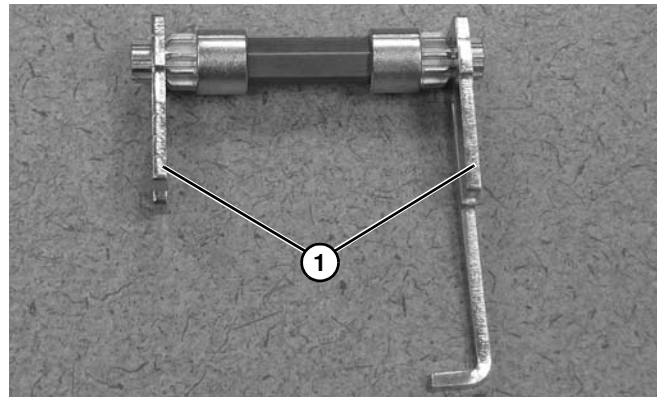

Figure 111

7. Insert pinion assembly (**Figure 112, item 1**) into conveyor frame.

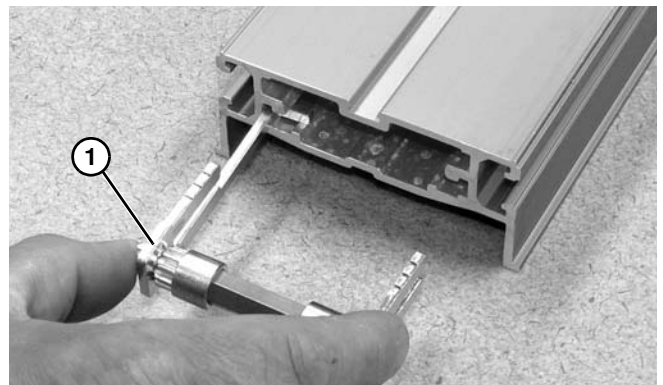

Figure 112

8. Tap alternating retaining plates (**Figure 113, item 1**) and (**Figure 114, item 1**) with a hammer until fully assembled onto conveyor frame.

⚠ CAUTION
Do not hit pinion gear with hammer. It may cause damage to the pinion teeth.

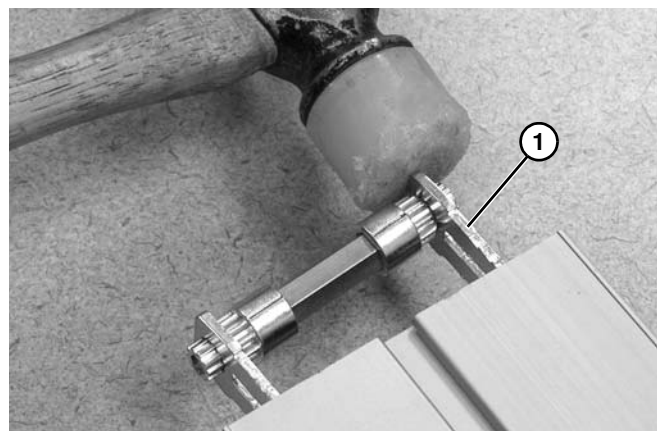

Figure 113

Preventive Maintenance and Adjustment

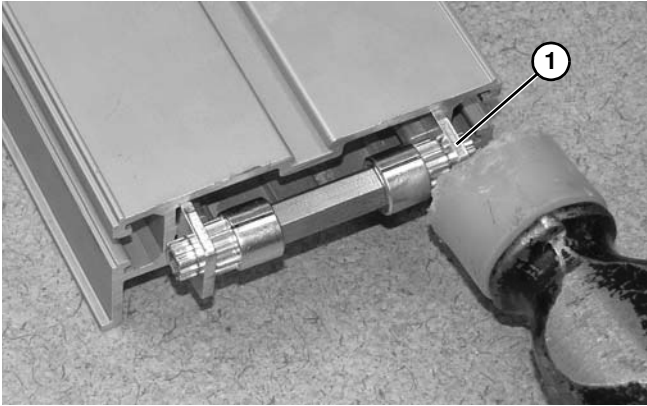

Figure 114

9. Insert both gear racks (**Figure 115, item 1**) into conveyor frame.

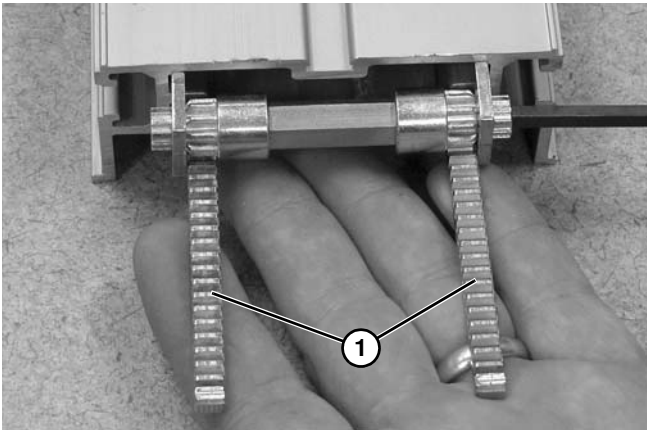

Figure 115

NOTE
<p><i>Make sure the bent end (Figure 116, item 1) of the gear rack is NOT assembled into the conveyor frame.</i></p>



Figure 116

10. Rotate pinion (**Figure 117, item 1**) with hex wrench until gear racks (**Figure 117, item 2**) are fully collapsed.

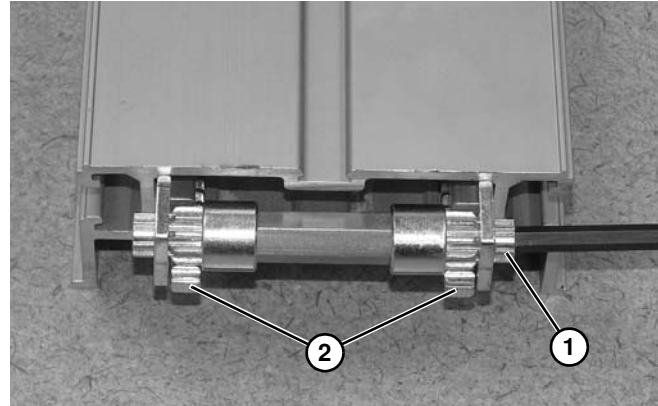

Figure 117

NOTE
<p><i>The gear racks must be aligned with each other, as shown above. Example of misaligned gear racks shown below.</i></p>

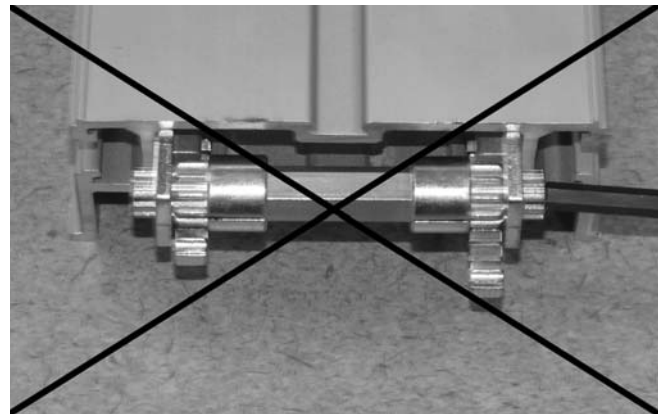

Figure 118

11. Reinstall idler tail by sliding tail assembly (**Figure 119, item 1**) fully back onto conveyor frame.

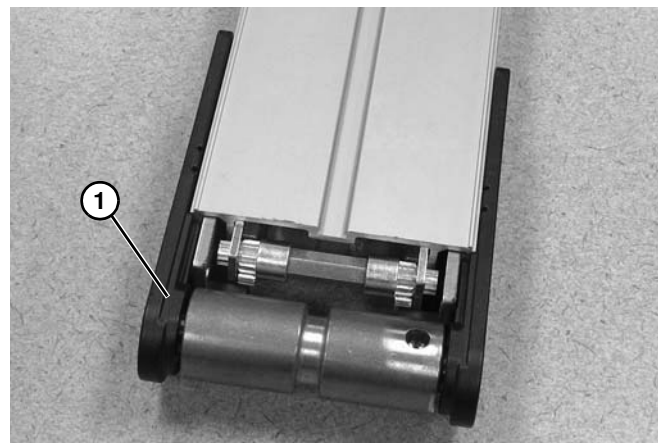



Figure 119

12. Reinstall belt on end of conveyor, then tension the belt. See "Conveyor Belt Tensioning" on page 22.

NOTE

For replacement parts other than those shown in this section, contact an authorized Dorner Service Center or the factory. Key Service Parts and Kits are identified by the Performance Parts Kits logo . Dorner recommends keeping these parts on hand.

End Drive Tail

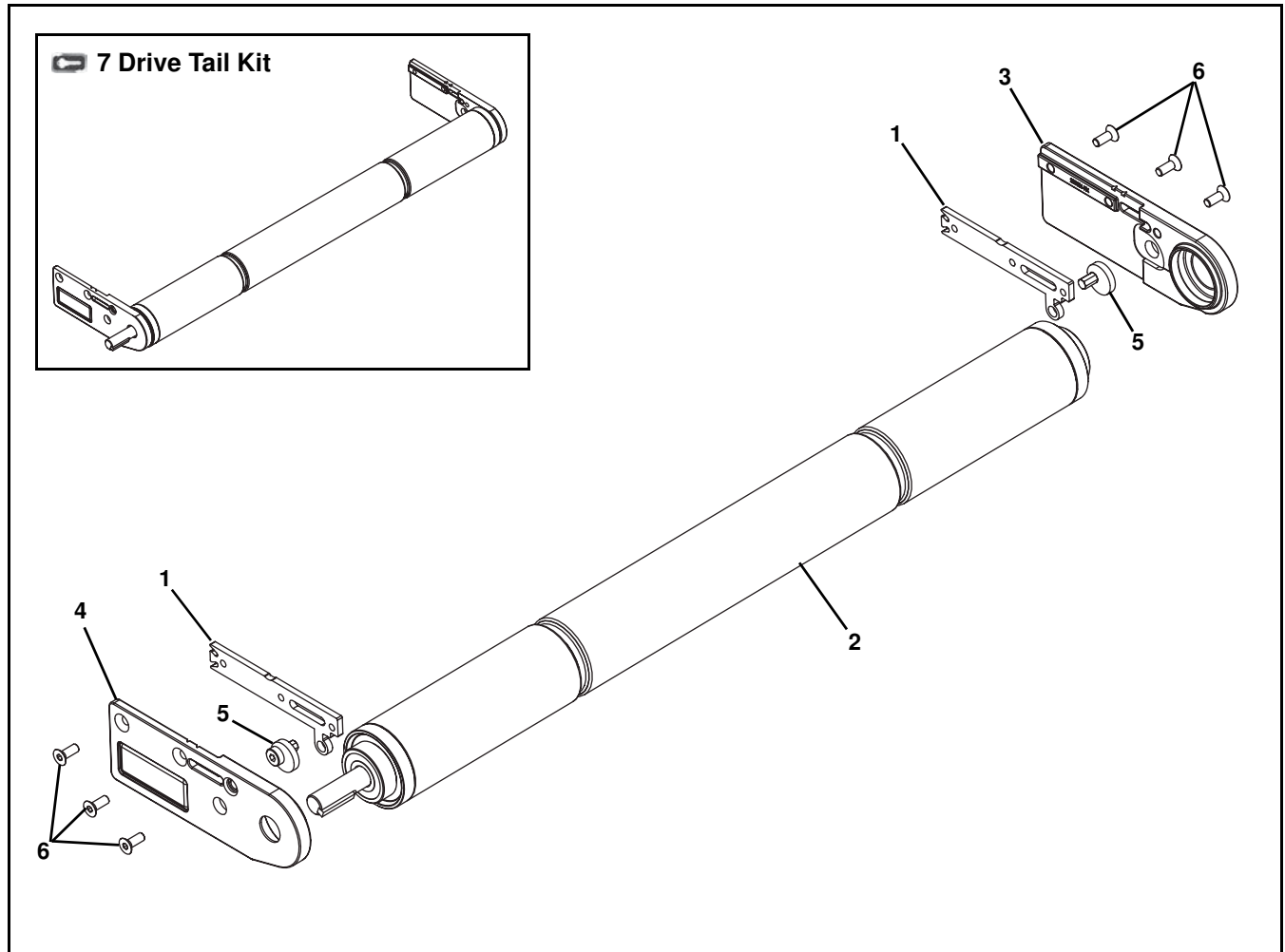

Item	Part Number	Description
1	208366	Nut Bar
2	208375- <u>WWWW</u> -M-0K	Spindle Assembly with Shaft in 'D' Position
	208375- <u>WWWW</u> -M-K0	Spindle Assembly with Shaft in 'A' Position
	208375- <u>WWWW</u> -M-KK	Dual Shaft Spindle Assembly
3	208381-F4	Left Hand Head Plate, without Shaft Hole
	208381-F5	Left Hand Head Plate, with Shaft Hole
4	208382-F4	Right Hand Head Plate, without Shaft Hole
	208382-F5	Right Hand Head Plate, with Shaft Hole
5	208463	Cam Assembly

Item	Part Number	Description
6	930616M	Flat Head Screw, M6-1.00 x 16 mm
	27DTK- <u>WWWW</u> -0K	Drive Tail Kit, with Shaft in "D" Position (Includes items 2, 3, and 4)
	27DTK- <u>WWWW</u> -K0	Drive Tail Kit, with Shaft in "A" Position (Includes items 2, 3, and 4)
	27DTK- <u>WWWW</u> -KK	Dual Shaft Drive Tail Kit (Includes items 2, 3, and 4)
<u>WWWW</u> = Conveyor width reference in mm 0203 - 0914		
See Specifications chart on page 7 for conveyor belt widths.		
Service parts can be obtained through your distributor or directly from Dorner Mfg. Corp. (800) 397-8664 or customerservice@dorner.com		

Service Parts

iDrive Tail

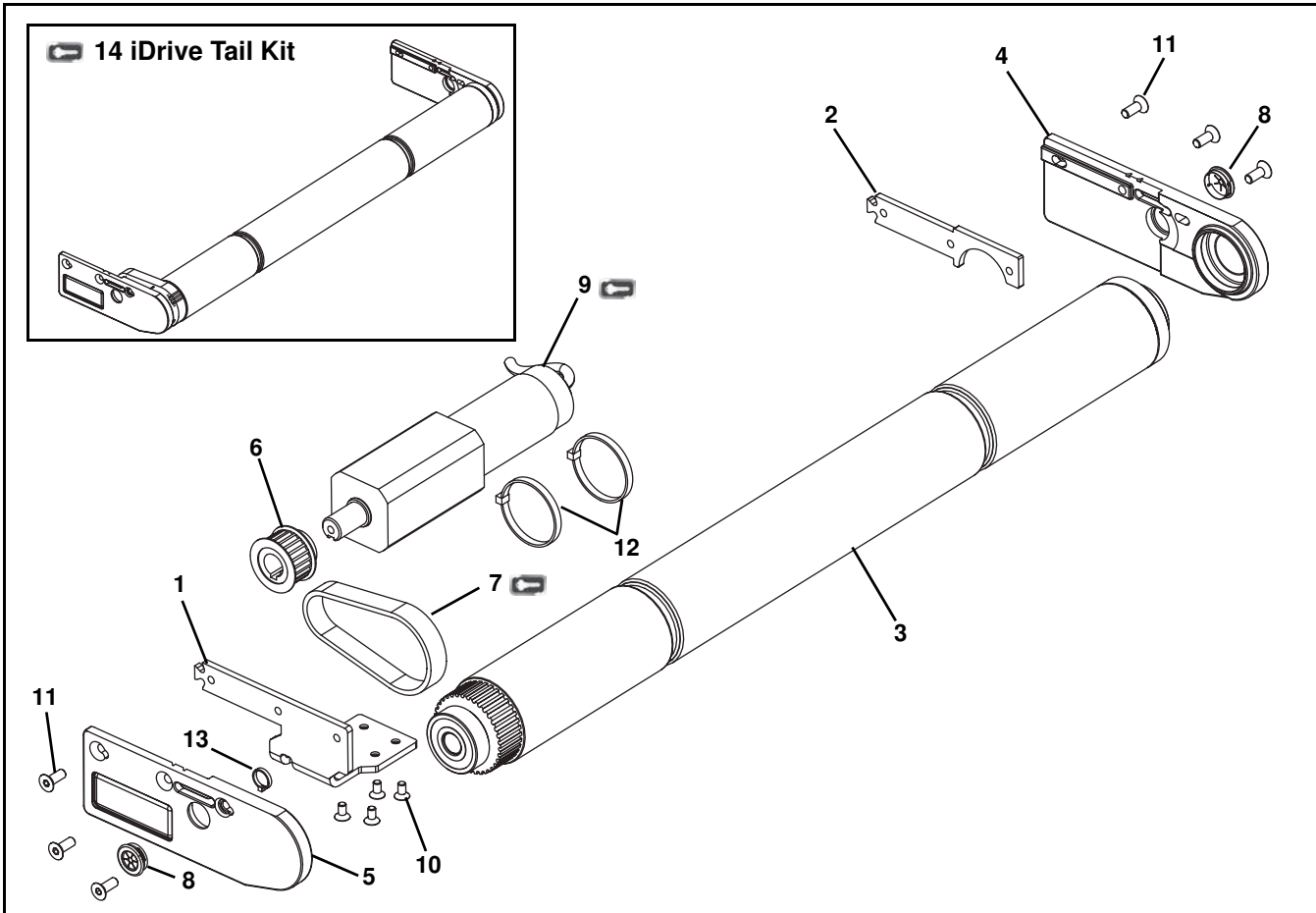

Item	Part Number	Description
1	208198-RH	iDrive Nut Bar for "D" Position
	208367	Nut Bar, on Opposite Side of Motor for 10" Wide Conveyors Only
2	208198-LH	iDrive Nut Bar for "A" Position
	208367	Nut Bar, on Opposite Side of Motor for 10" Wide Conveyors Only
3	208406- <u>WWWW</u> -M	Spindle Assembly
4	208381-F3	Head Plate, Left Hand
5	208382-F3	Head Plate, Right Hand
6	208400	Pulley, 22 Tooth
7	814-504	Timing Belt, 5 mm
8	824-679	Grommet

Item	Part Number	Description
9	826-984	Gearmotor, Belt Speed 33 FPM, 87 RPM, Speed Letter G
	826-985	Gearmotor, Belt Speed 49 FPM, 129 RPM, Speed Letter F
	826-986	Gearmotor, Belt Speed 67 FPM, 176 RPM, Speed Letter E
	826-987	Gearmotor, Belt Speed 82 FPM, 215 RPM, Speed Letter D
	826-988	Gearmotor, Belt Speed 120 FPM, 317 RPM, Speed Letter C
	826-989	Gearmotor, Belt Speed 147 FPM, 387 RPM, Speed Letter B
	826-990	Gearmotor, Belt Speed 201 FPM, 529 RPM, Speed Letter A
	10	930510M
11	930620M	Flat Head Screw, M6-1.00 x 20 mm
12	805-064	Wire Tie, 11.5" long
13	805-1080	Wire Tie, 4" long
14	27FTK- <u>WWWW</u>	iDrive Spindle Kit (Includes items 3, 4, 5, and 7)
<u>WWWW</u> = Conveyor width reference in mm 0254 - 0914		
See Specifications chart on page 7 for conveyor belt widths.		
Service parts can be obtained through your distributor or directly from Dorner Mfg. Corp. (800) 397-8664 or customerservice@dorner.com		

iDrive Controller

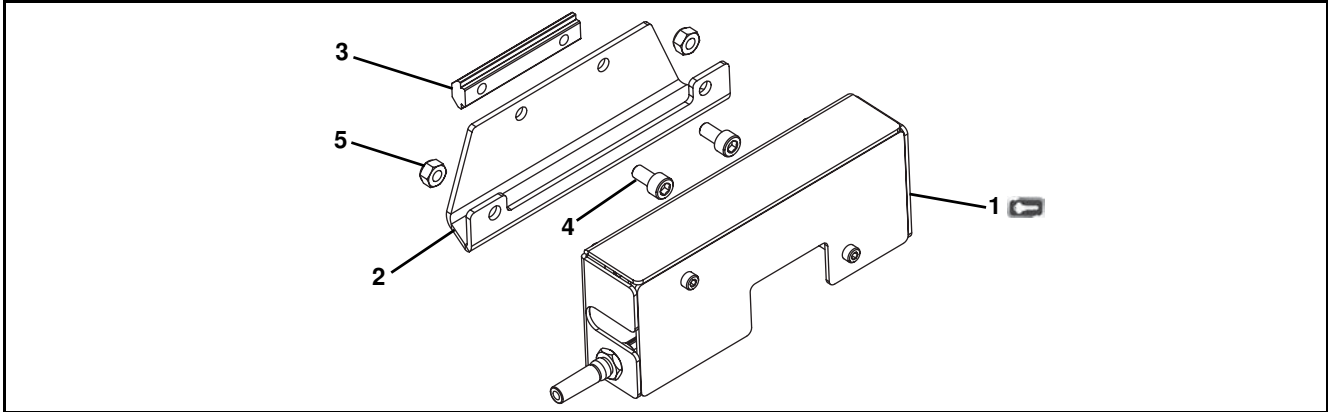

Item	Part Number	Description
1	208451	Controller Assembly
2	351510	Mounting Bracket
3	300150M	Drop-In Tee Bar
4	920612M	Socket head Screw, M6-1.00 x 12 mm
5	990602M	Lock Nut

See Specifications chart on page 7 for conveyor belt widths.

Service parts can be obtained through your distributor or directly from Dorner Mfg. Corp. (800) 397-8664 or customerservice@dorner.com

Service Parts

Idler Tail

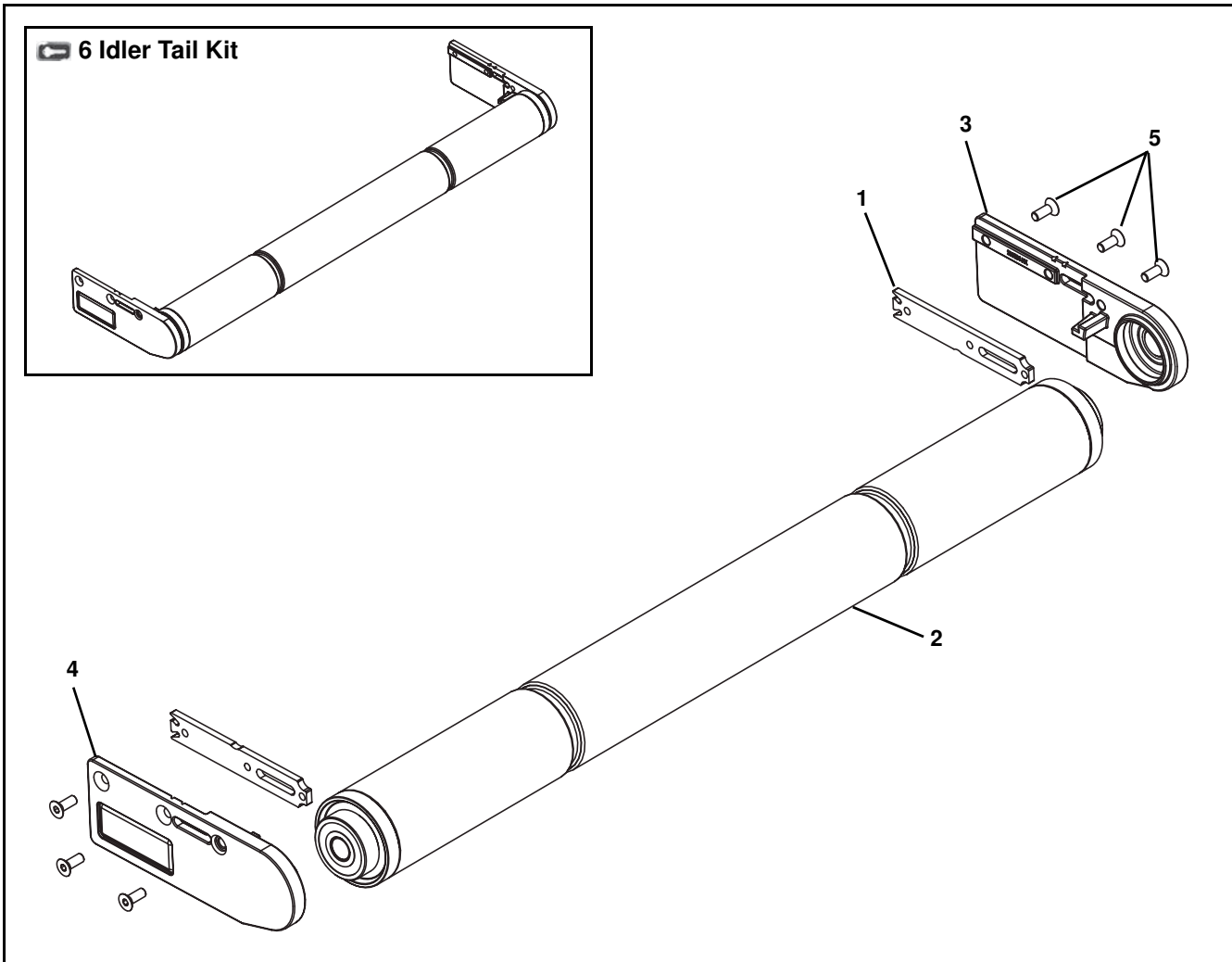

Item	Part Number	Description
1	208366	Nut Bar
2	208375- <u>WWWW</u> -M-00	Spindle Assembly without Auxiliary Shaft Hole
	208375- <u>WWWW</u> -M-0K	Spindle Assembly with Auxiliary Shaft on the "A" Side
	208375- <u>WWWW</u> -M-K0	Spindle Assembly with Auxiliary Shaft on the "D" Side
3	208381-F2	Left Hand Head Plate without Shaft Hole
	208381-F6	Left Hand Head Plate with Shaft Hole
4	208382-F2	Right Hand Head Plate without Shaft Hole
	208382-F6	Right Hand Head Plate with Shaft Hole

Item	Part Number	Description
5	930616M	Flat Head Screw, M6-1.00 x 16 mm
6	27TTK- <u>WWWW</u> -00	Idler Tail Kit without Auxiliary Shaft Hole (Includes items 2, 3, and 4)
	27TTK- <u>WWWW</u> -0K	Idler Tail Kit with Auxiliary Shaft on the "A" Side (Includes items 2, 3, and 4)
	27TTK- <u>WWWW</u> -K0	Idler Tail Kit with Auxiliary Shaft on the "D" Side (Includes items 2, 3, and 4)
<u>WWWW</u> = Conveyor width reference in mm 0203 - 0914		
See Specifications chart on page 7 for conveyor belt widths.		
Service parts can be obtained through your distributor or directly from Dorner Mfg. Corp. (800) 397-8664 or customerservice@dorner.com		

5/8" (16 mm) Nosebar Tail

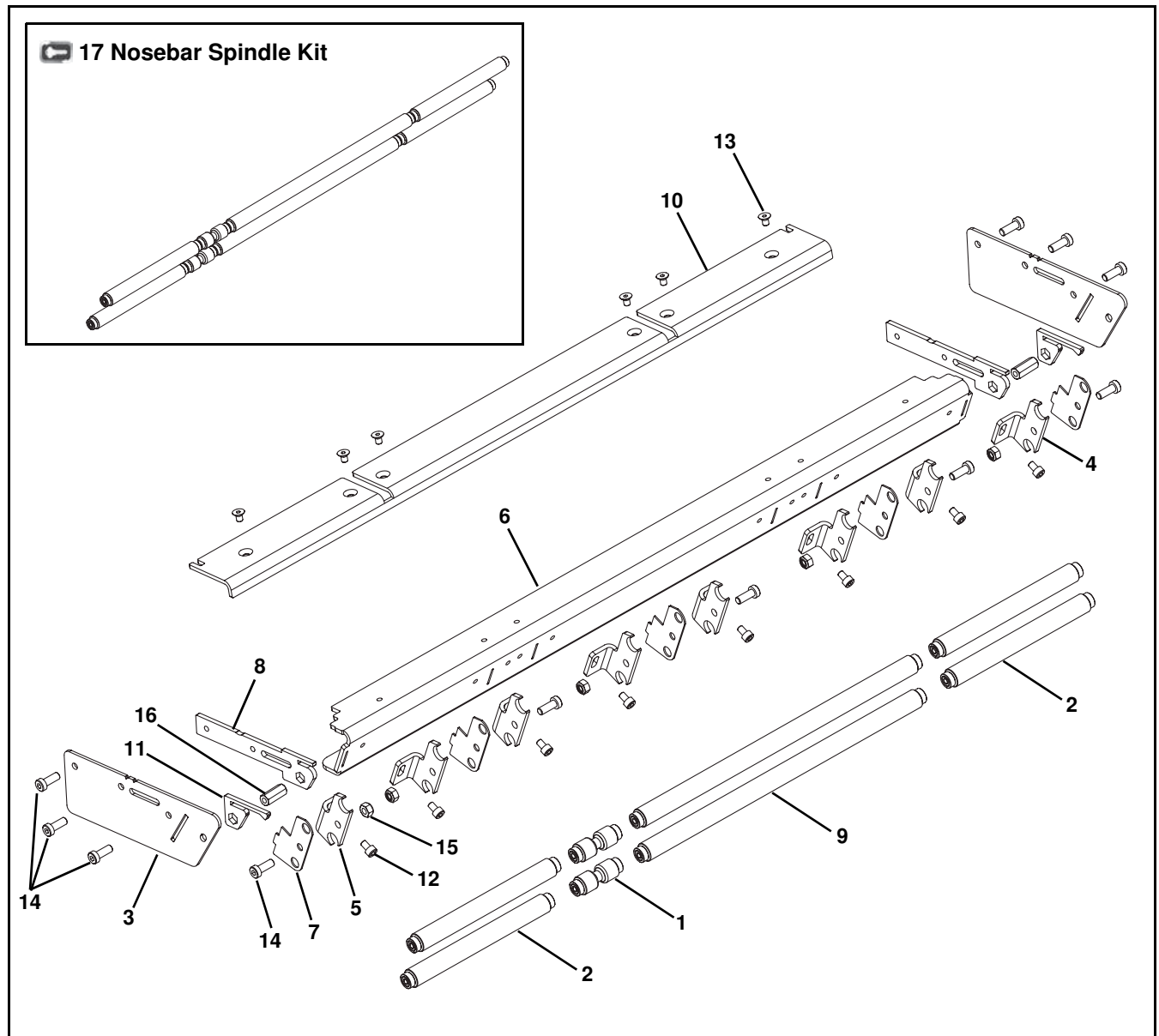

Item	Part Number	Description
1	205526- <u>WWWW</u> -M	Spindle Assembly, V-Groove
2	205527- <u>WWWW</u> -M	Spindle Assembly, Smooth
3	208379	Tail Plate
4	208385-LH	Roller Support, Left Hand
5	208385-RH	Roller Support, Right Hand
6	208386- <u>WWWW</u> -M	Support Channel
7	208387	End Plate
8	208388	Nut Bar
9	208389	Spindle Assembly for Conveyors 26" wide and wider
10	208391- <u>WWWW</u> -M	Top Transfer Plate
11	208486	Spacer Plate
12	920510MF	Flanged Socket Head Screw, M5-0.80 x 10 mm

Item	Part Number	Description
13	930508M	Flat Head Screw, M5-0.80 x 8 mm
14	950616M	Low Head Cap Screw, M6-1.00 x 16 mm
15	990602M	Lock Nut
16	807-2862	Hex Post
17	27NTK- <u>WWWW</u>	Nosebar Spindle Kit (Includes items 1, 2, and 9)

WWWW = Conveyor width reference in mm 0203 - 0914

See Specifications chart on page 7 for conveyor belt widths.

Service parts can be obtained through your distributor or directly from Dorner Mfg. Corp. (800) 397-8664 or customerservice@dorner.com

Service Parts

Mid Drive Module

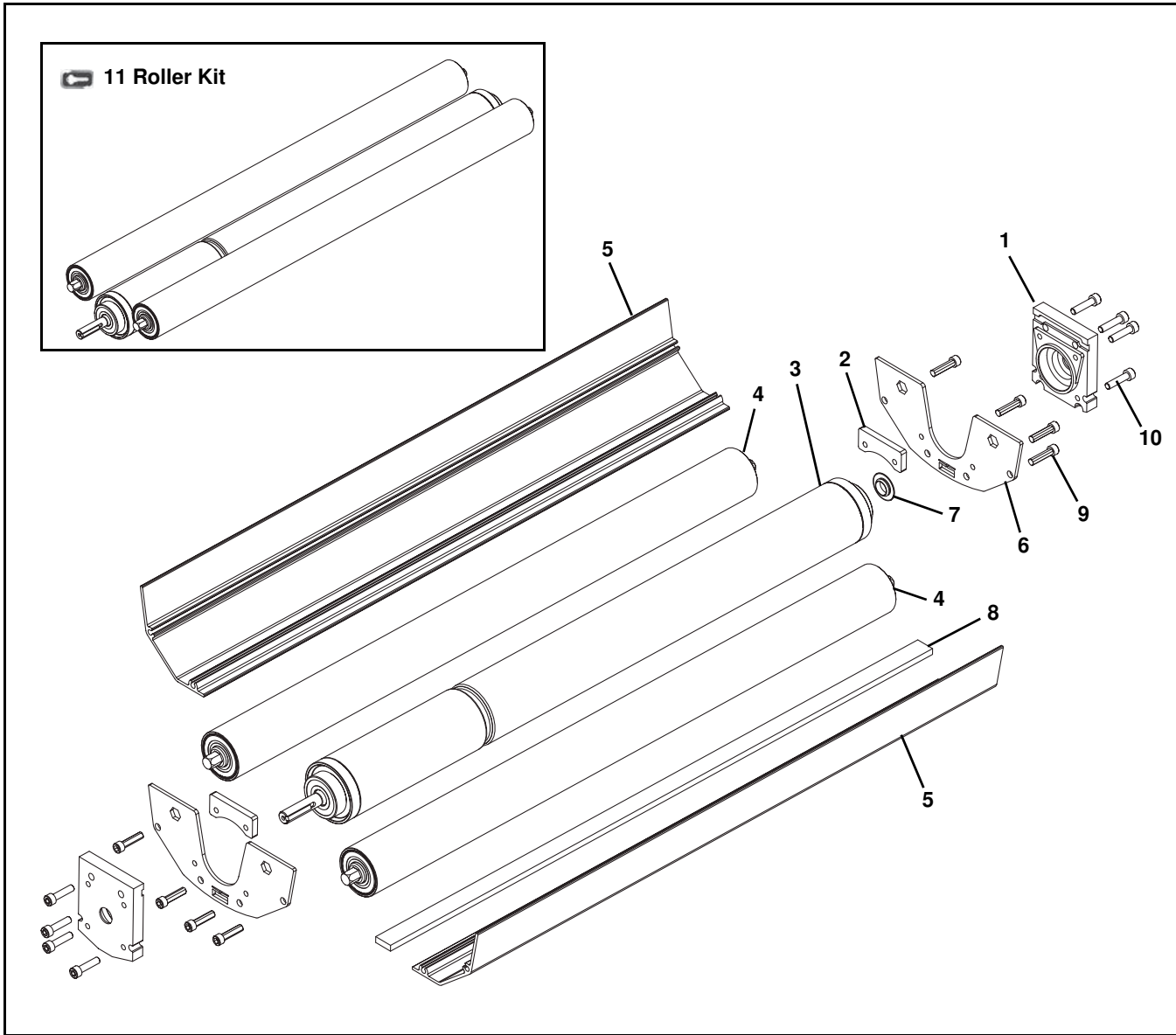

Item	Part Number	Description
1	208410	Bearing Block
2	208412	Clamp Block
3	208375- <u>WWWWW</u> -M-OK	Spindle Assembly
	208375- <u>WWWWW</u> -M-KK	Dual Shaft Spindle Assembly
4	207332- <u>WWWWW</u> -M	Roller Assembly
5	202455- <u>WWWWW</u> -M	Bottom Guard
6	208418	Side Plate
7	807-2852	Plug
8	11954- <u>WWWWW</u> -M	Bar
9	708180P	Trilobe Screw, M6-1.00 x 25 mm

Item	Part Number	Description
10	920625M	Socket Head Screw, M6-1.00 x 25 mm
11	27MRK- <u>WWWWW</u> -OK	Roller Kit (Includes items 3 and 4)
	27MRK- <u>WWWWW</u> -KK	Dual Shaft Roller Kit (Includes items 3 and 4)
<u>WWWWW</u> = Conveyor width reference in mm 0203 - 0914		
See Specifications chart on page 7 for conveyor belt widths.		
Service parts can be obtained through your distributor or directly from Dornier Mfg. Corp. (800) 397-8664 or customerservice@dornier.com		

Frame Assembly

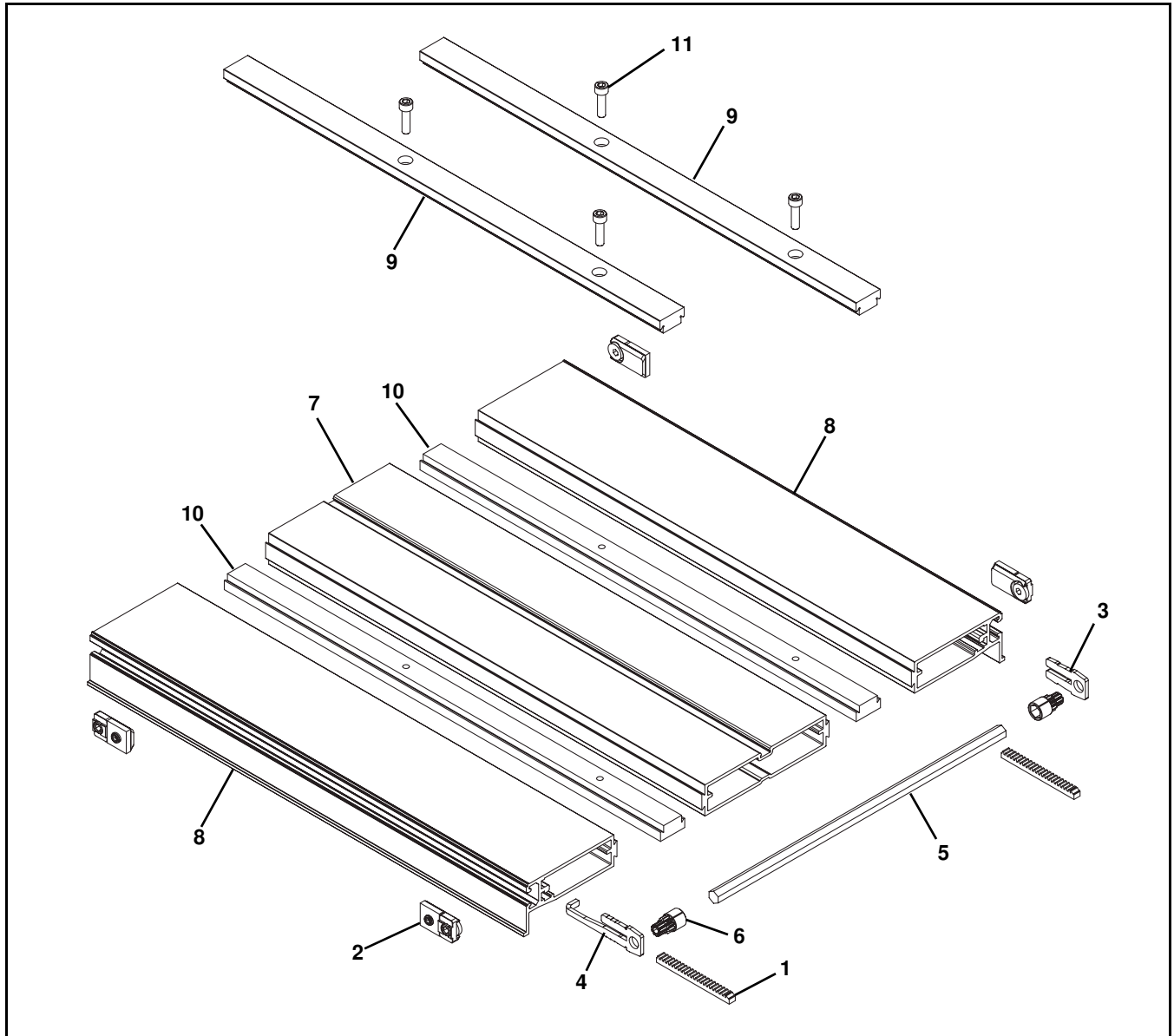

Item	Part Number	Description
1	203595	Gear Rack
2	208500	Tracking Cam Assembly
3	205450	Retaining Plate, Left Hand
4	205450RH	Retaining Plate, Right Hand
5	205469- <u>WWWW</u> -M	Hex Pinion
6	205383	Pinion End Gear
7	205396- <u>LLLLL</u>	Mid Frame for 14", 16", 18", 26", 28" & 30" wide Conveyors
	205398- <u>LLLLL</u>	Mid Frame for 20" thru 36" wide Conveyors

Item	Part Number	Description
8	207748- <u>LLLLL</u> -M	Outside Frame for 8", 14", 20", 26", & 32" wide Conveyors (Qty. 2)
	207749- <u>LLLLL</u> -M	Outside Frame for 10", 16", 22", 28", & 34" wide Conveyors (Qty. 2)
	207750- <u>LLLLL</u> -M	Outside Frame for 12", 18", 24", 30", & 36" wide Conveyors (Qty. 2)
9	206505- <u>LLLLL</u>	Upper Connecting Strip
10	206506- <u>LLLLL</u>	Lower Connecting Strip
11	920622M	Socket Head Screw, M6-1.00 x 22 mm

LLLLL = part length in mm with one decimal place

Example: Part length = 1200 mm LLLLL = 12000

WWWW = Conveyor width reference in inches 08 - 36

See Specifications chart on page 7 for conveyor belt widths.

Service parts can be obtained through your distributor or directly from Dorner Mfg. Corp. (800) 397-8664 or customerservice@dorner.com

Service Parts

#04 Profile - 3.00" (76 mm) Aluminum Side

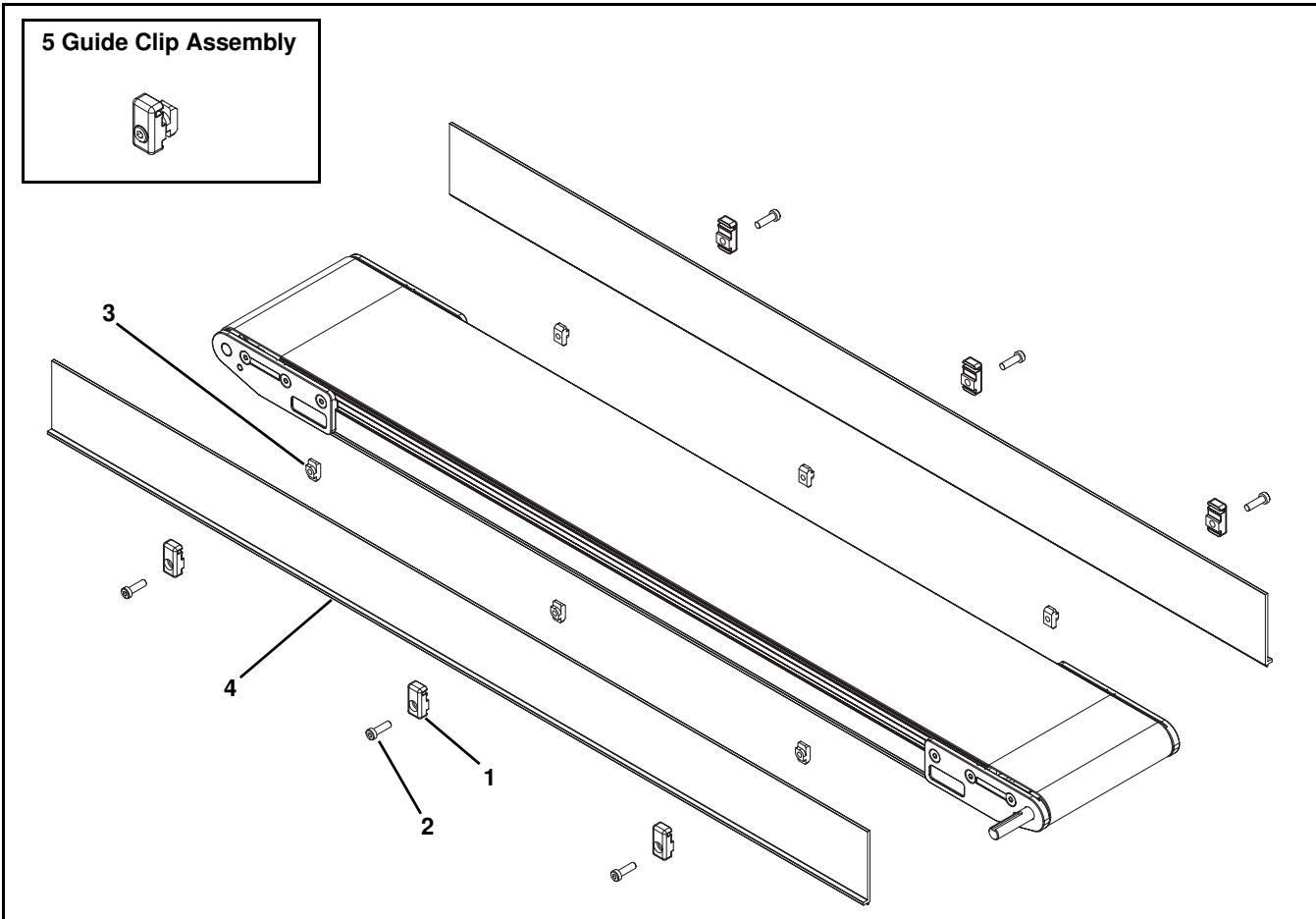

Item	Part Number	Description
1	206503	Guide Clip
2	807-2878	Low Head Cap Screw, M6-1.00 x 16 mm
3	206685	T-Nut
4	206514- <u>LLLLL</u>	3.00" Guides
	GTB04A04	3.00" Guides 4' long
	GTB04A08	3.00" Guides 8' long
5	203661	Guide Clip Assembly (Includes items 1, 2, and 3)

LLLLL = part length in inches with 2 decimal places

Length Example: Length = 35.25" LLLLL = 03525

Service parts can be obtained through your distributor or directly from Dorner Mfg. Corp. (800) 397-8664 or customerservice@dorner.com

#05 Profile - 1.50" (38 mm) Aluminum Side

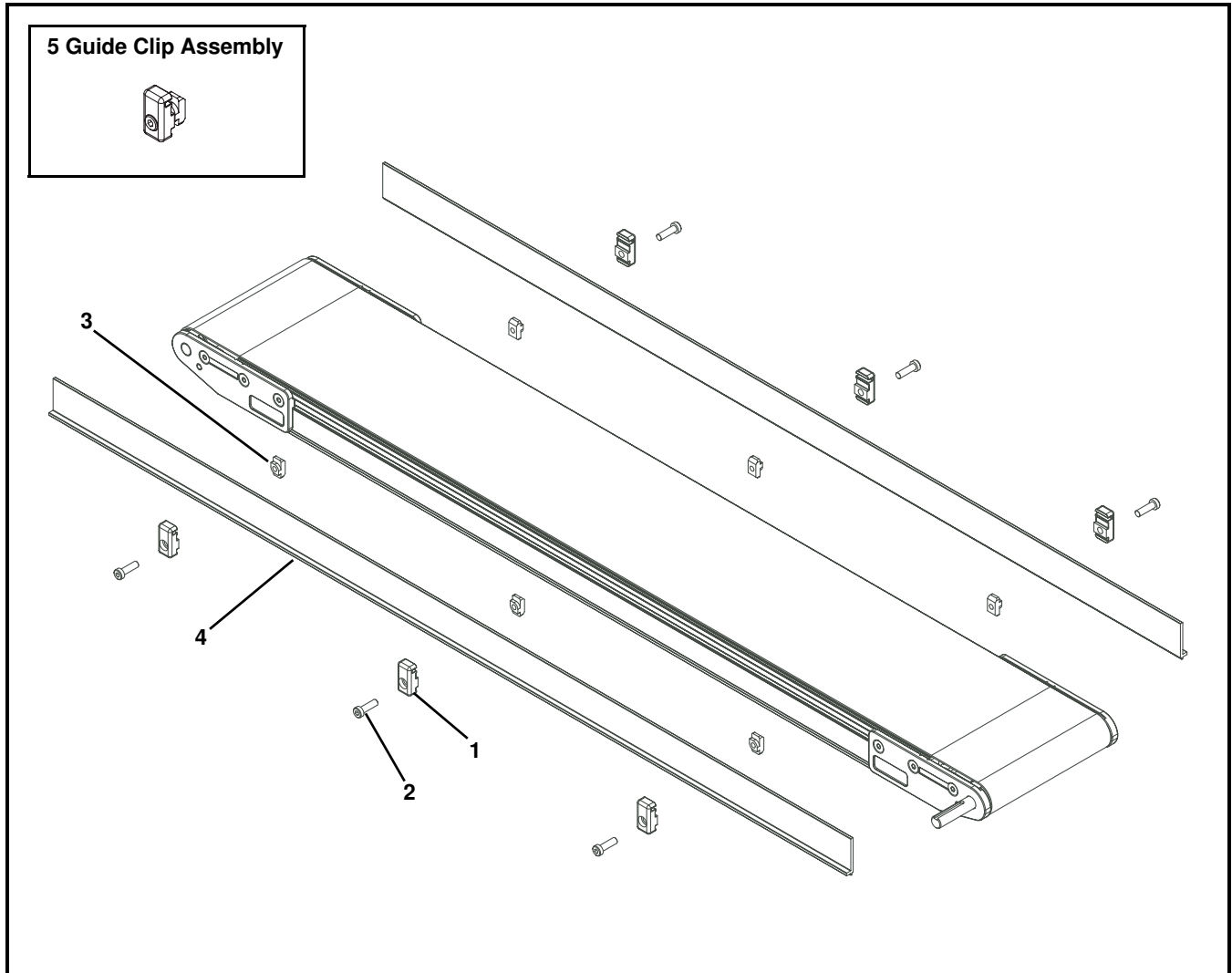

Item	Part Number	Description
1	206503	Guide Clip
2	807-2878	Low Head Cap Screw, M6-1.00 x 16 mm
3	206685	T-Nut
4	206513-LLLLL	1.50" Guides
	GTB05A04	1.50" Guides 4' long
	GTB05A08	1.50" Guides 8' long
5	203661	Guide Clip Assembly (Includes items 1, 2, and 3)
LLLLL = part length in inches with 2 decimal places		
Length Example: Length = 35.25" LLLLL = 03525		
Service parts can be obtained through your distributor or directly from Dorner Mfg. Corp. (800) 397-8664 or customerservice@dorner.com		

Service Parts

#07 Profile - Low to Side Wiper

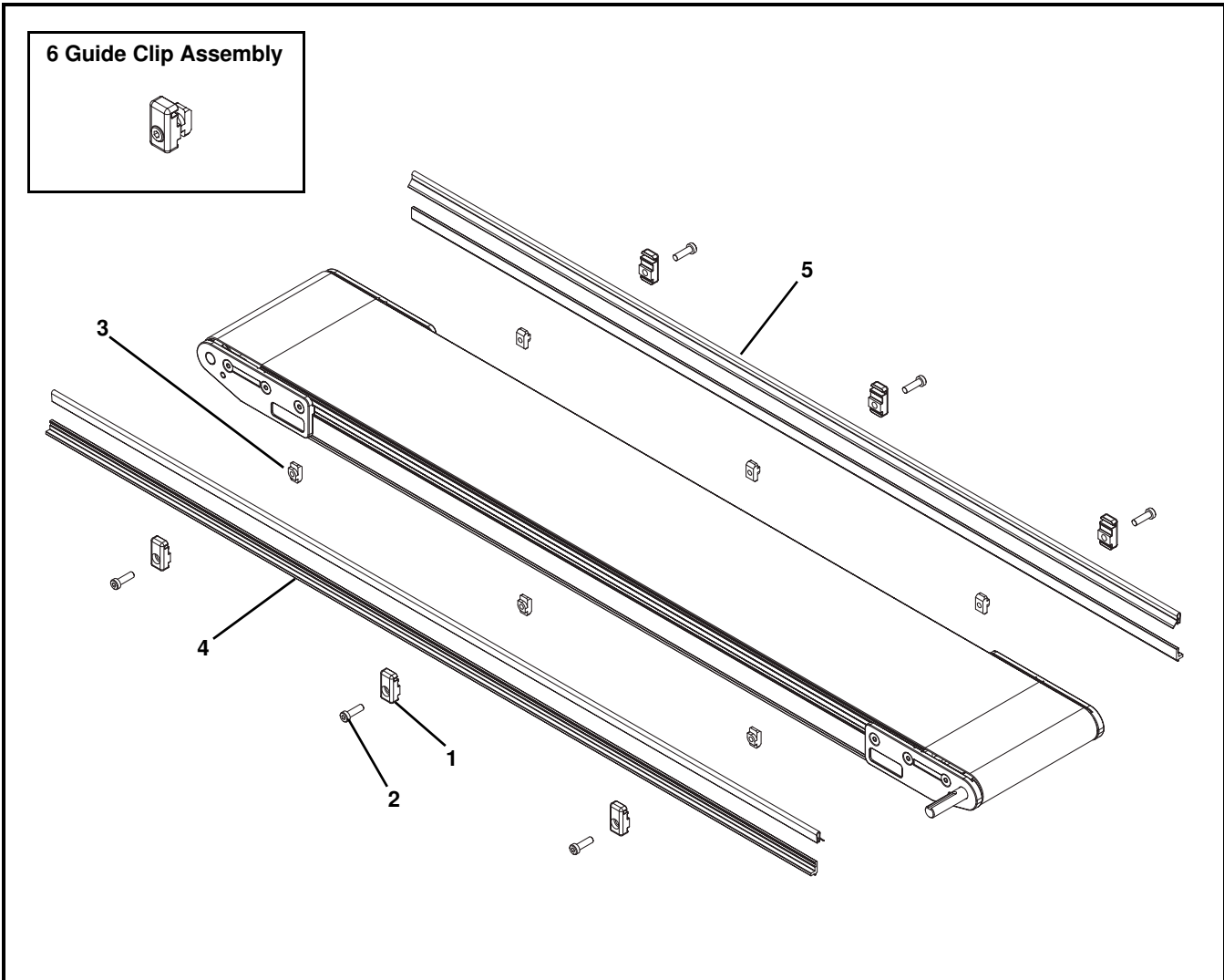

Item	Part Number	Description
1	207136	Guide Clip
2	807-2878	Low Head Cap Screw, M6-1.00 x 16 mm
3	206685	T-Nut
4	206512-LLLLL	.50" Guides
	GTB09A04	.50" Guides 4' long
	GTB09A08	.50" Guides 8' long
5	41-00-24	Side Wiper (per foot)
6	203662	Guide Clip Assembly (Includes items 1, 2, and 3)

LLLLL = part length in inches with 2 decimal places

Length Example: Length = 35.25" LLLLL = 03525

Service parts can be obtained through your distributor or directly from Dorner Mfg. Corp. (800) 397-8664 or customerservice@dorner.com

#09 Profile - Low to High Side

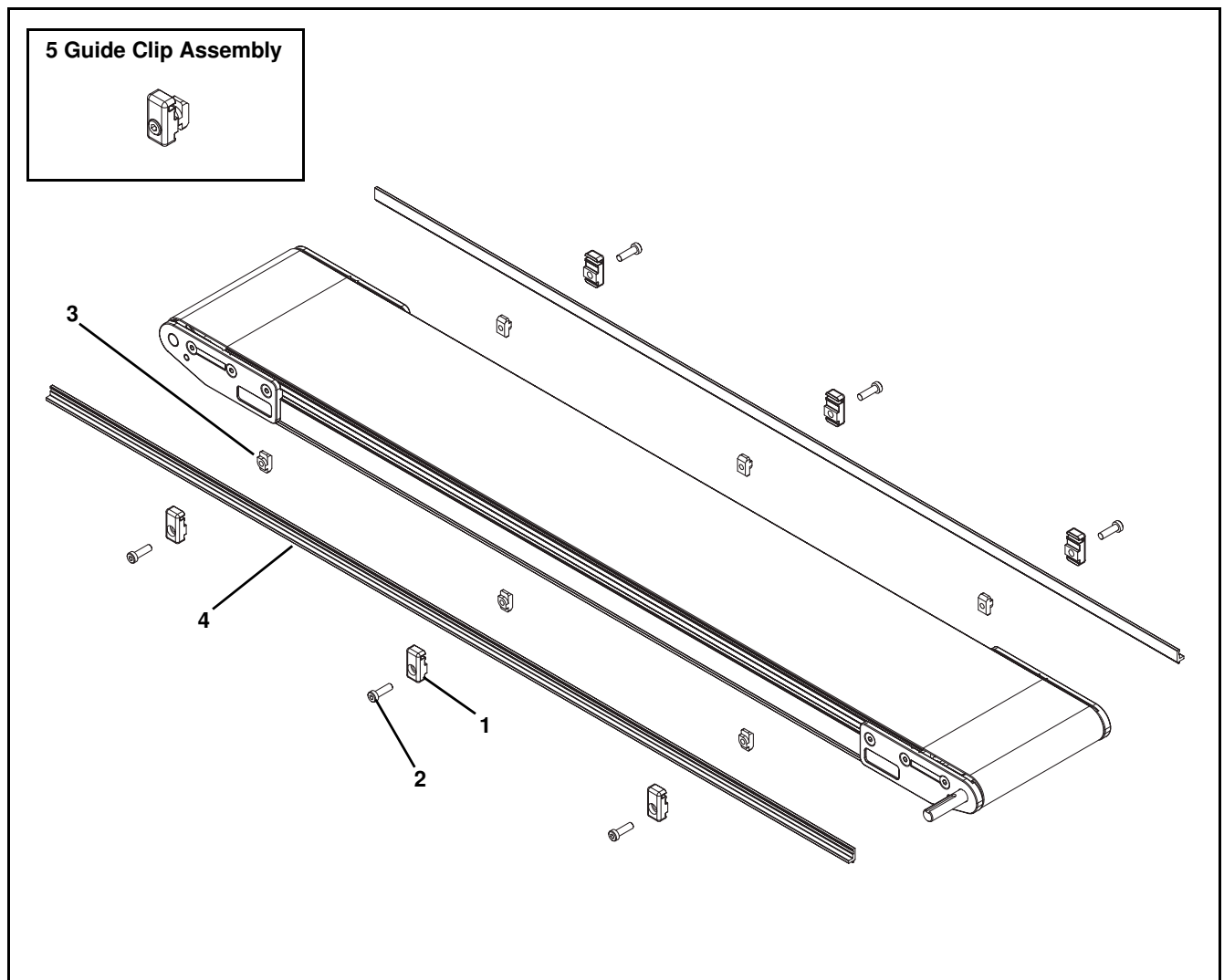

Item	Part Number	Description
1	206503	Guide Clip
2	807-2878	Low Head Cap Screw, M6-1.00 x 16 mm
3	206685	T-Nut
4	206512- <u>LLLLL</u>	.50" Guides
	GTB09A04	.50" Guides 4' long
	GTB09A08	.50" Guides 8' long
5	203661	Guide Clip Assembly (Includes items 1, 2, and 3)
<u>LLLLL</u> = part length in inches with 2 decimal places		
Length Example: Length = 35.25" <u>LLLLL</u> = 03525		
Service parts can be obtained through your distributor or directly from Dorner Mfg. Corp. (800) 397-8664 or customerservice@dorner.com		

Service Parts

#10 Profile - 0.5" (13 mm) Extruded Plastic Side

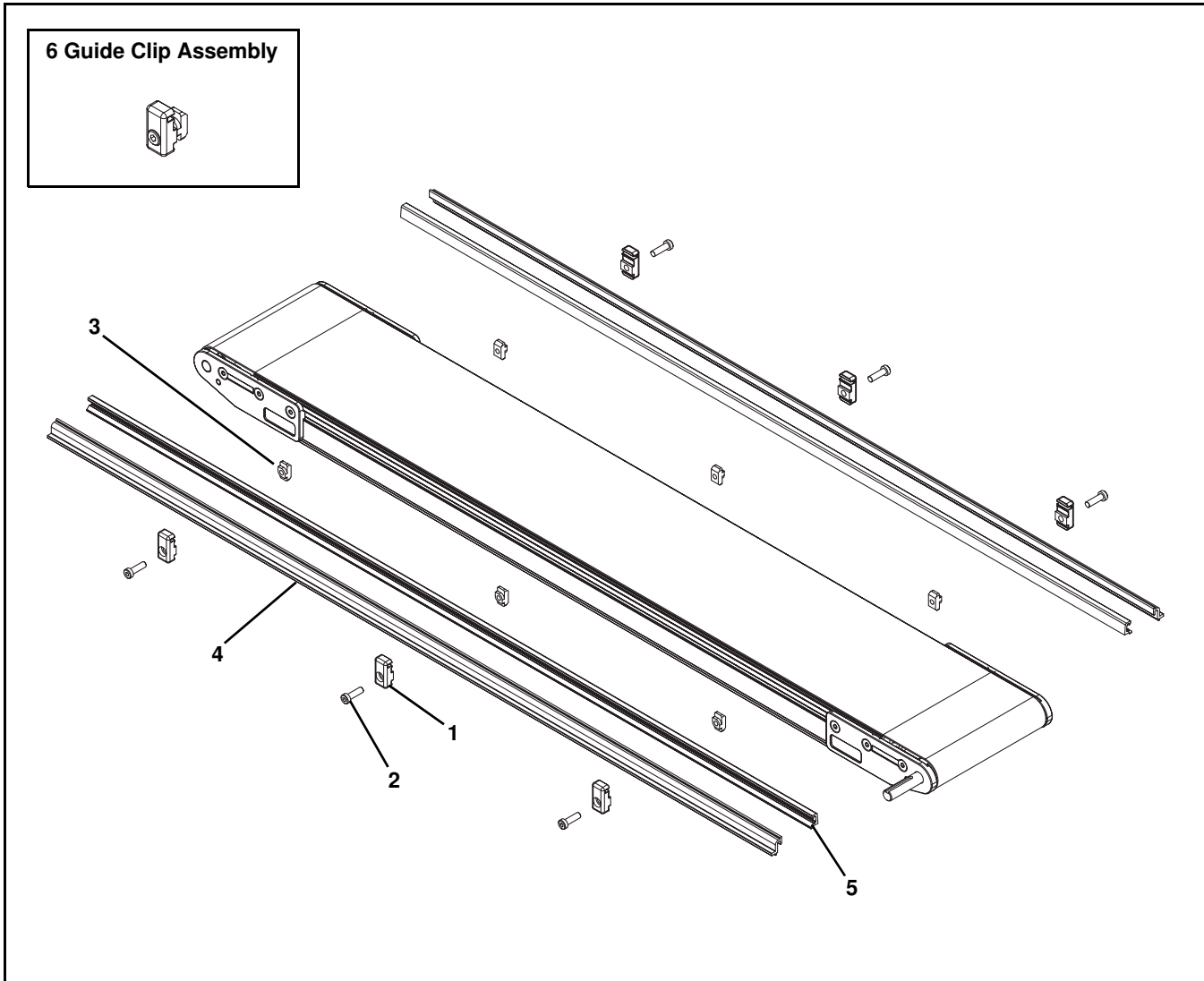

Item	Part Number	Description
1	206503	Guide Clip
2	807-2878	Low Head Cap Screw, M6-1.00 x 16 mm
3	206685	T-Nut
4	206511-LLLLL	.50" Guides
5	203770	Snap-On Guides (per foot)
6	203661P	Guide Clip Assembly (Includes items 1, 2, and 3)
LLLLL = part length in inches with 2 decimal places		
Length Example: Length = 35.25" LLLLL = 03525		
Service parts can be obtained through your distributor or directly from Dorner Mfg. Corp. (800) 397-8664 or customerservice@dorner.com		

#13, 33 & 43 Profile - Adjustable Guiding

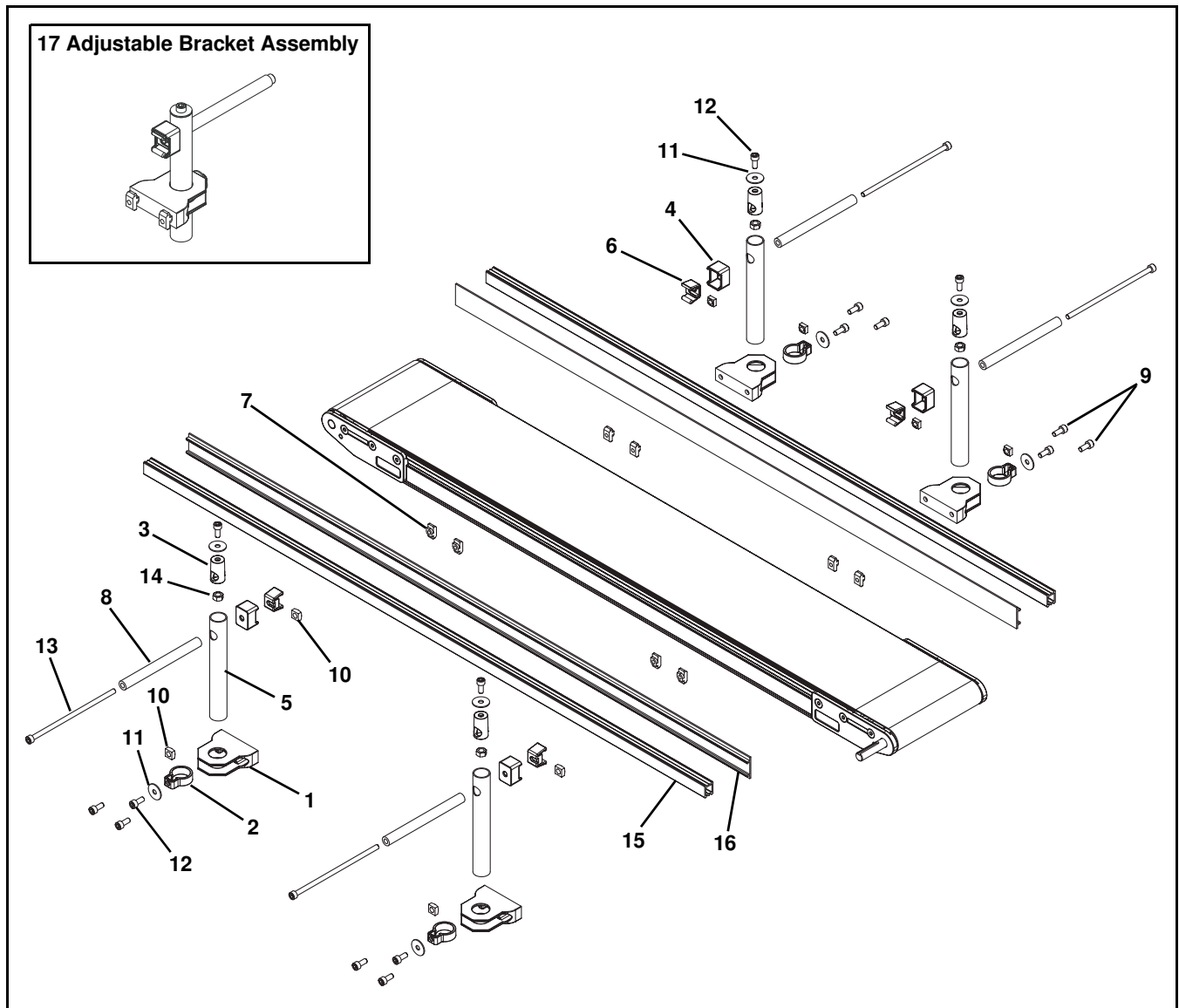

Item	Part Number	Description
1	206380	Base
2	206381	Base Clamp
3	206382	Insert Clamp
4	206383	Guide Ring
5	206385	Tube
6	206397	Clip
7	206685	T-Nut
8	206692	Guide Tube
9	807-2859	Nylon Cap Screw, M6 x 16 mm
10	990603M	Square Nut, M6-1.0
11	911-710	Washer
12	920616M	Socket Head Screw, M6-1.00 x 16 mm
13	9206150M	Socket Head Screw, M6-1.00 x 150 mm
14	990601M	Hex Nut

Item	Part Number	Description
15	834-238-LLLLL	Guide Rail
	GTB13A04	Guide Rail 4' long
	GTB13A08	Guide Rail 8' long
16	834-241	1.3" UHMW Guiding (per foot)
	GTB13B04	1.3" UHMW Guiding 4' long
	GTB13B08	1.3" UHMW Guiding 8' long
	206683	2" UHMW Guiding (per foot)
	GTB13C04	2" UHMW Guiding 4' long
	GTB13C08	2" UHMW Guiding 8' long
17	206686	Adjustable Bracket Assembly (Includes Items 1 through 14)

LLLLL = part length in inches with 2 decimal places
 Length Example: Length = 35.25" LLLLL = 03525

Service parts can be obtained through your distributor or directly from Dorner Mfg. Corp. (800) 397-8664 or customerservice@dorner.com

Service Parts

#14, 34 & 44 Profile - Tool-Less Adjustable Guiding

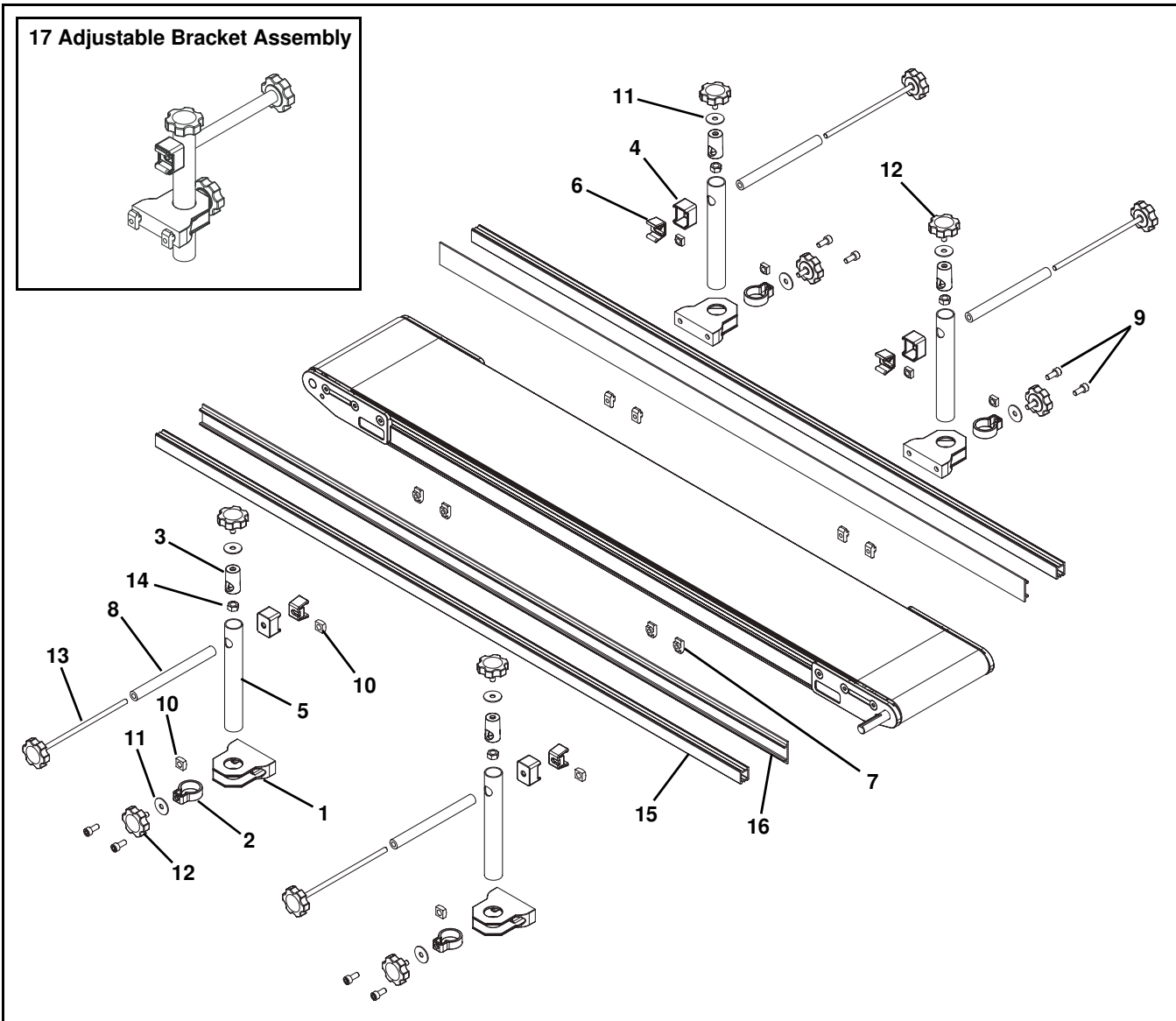

Item	Part Number	Description
1	206380	Base
2	206381	Base Clamp
3	206382	Insert Clamp
4	206383	Guide Ring
5	206385	Tube
6	206397	Clip
7	206685	T-Nut
8	206692	Guide Tube
9	807-2859	Nylon Cap Screw, M6 x 16 mm
10	990603M	Square Nut, M6-1.0
11	911-710	Washer
12	206698	Knob, 12 mm
13	206697	Knob, 150 mm
14	990601M	Hex Nut

Item	Part Number	Description
15	834-238-LLLLL	Guide Rail
	GTB13A04	Guide Rail 4' long
	GTB13A08	Guide Rail 8' long
16	834-241	1.3" UHMW Guiding (per foot)
	GTB13B04	1.3" UHMW Guiding 4' long
	GTB13B08	1.3" UHMW Guiding 8' long
	206683	2" UHMW Guiding (per foot)
	GTB13C04	2" UHMW Guiding 4' long
GTB13C08	2" UHMW Guiding 8' long	
17	206687	Tool-Less Adjustable Bracket Assembly (Includes Items 1 through 14)

LLLLL = part length in inches with 2 decimal places

Length Example: Length = 35.25" LLLLL = 03525

Service parts can be obtained through your distributor or directly from Dornier Mfg. Corp. (800) 397-8664 or customerservice@dornier.com

#16, 36 & 46 Profile - Outboard Adjustable Guiding

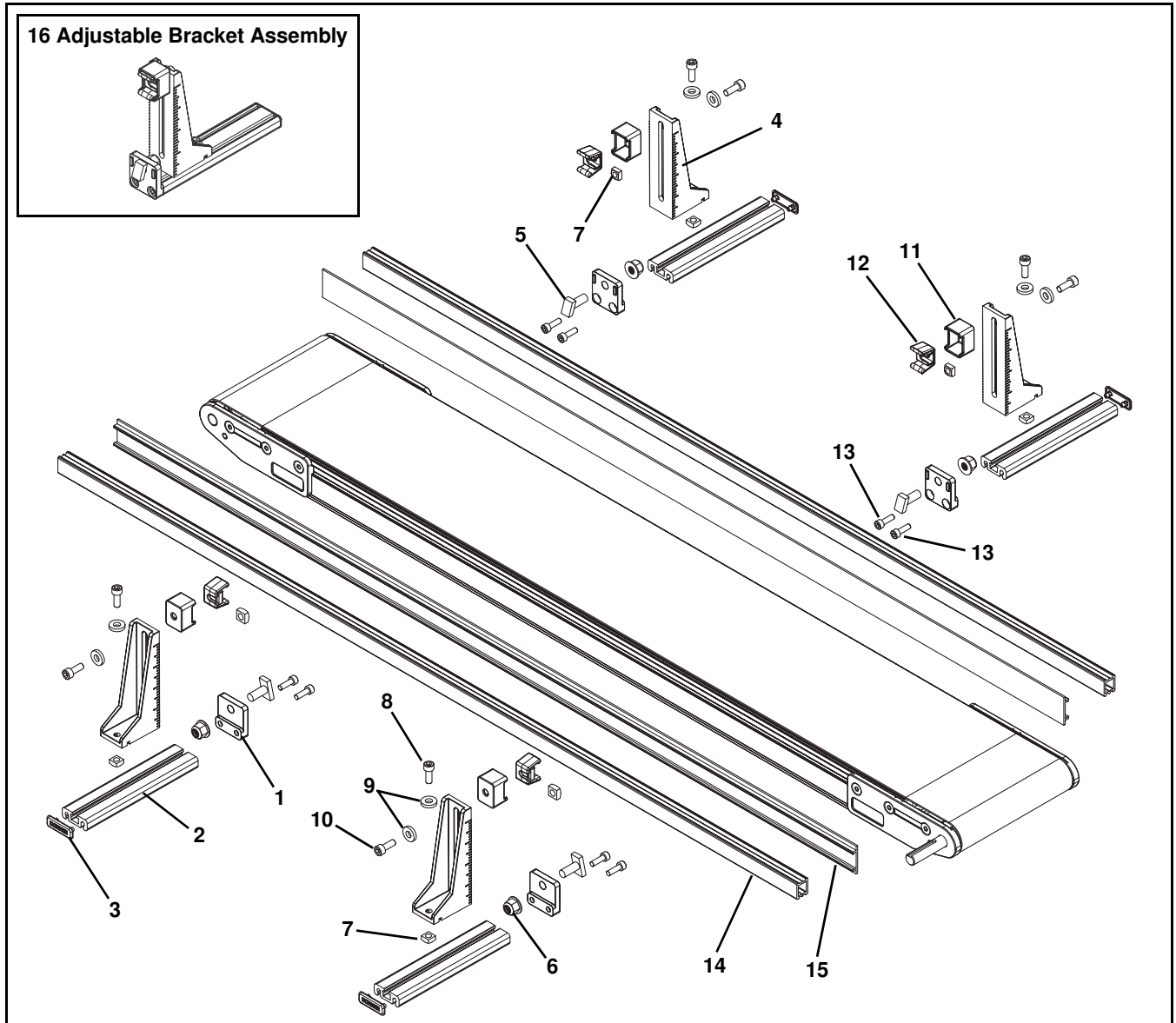

Item	Part Number	Description
1	210848	Mounting Block
2	210846-00600	Extrusion Base
3	210849	Cap
4	210847	Mounting Bracket
5	834-007	Stud, M8 x 20 mm
6	990812M	Hex Nut, M8-1.25
7	990603M	Square Nut, M6-1.0
8	920616M	Socket Head Screw, M6-1.00 x 16 mm
9	605279P	Washer
10	920622M	Socket Head Screw, M6-1.00 x 22 mm
11	206383	Guide Ring
12	206397	Clip
13	920516M	Socket Head Screw, M5-0.80 x 16 mm

Item	Part Number	Description
14	834-238- <u>LLLLL</u>	Guide Rail
	GTB13A04	Guide Rail 4' long
	GTB13A08	Guide Rail 8' long
15	834-241	1.3" UHMW Guiding (per foot)
	GTB13B04	1.3" UHMW Guiding 4' long
	GTB13B08	1.3" UHMW Guiding 8' long
	206683	2" UHMW Guiding (per foot)
	GTB13C04	2" UHMW Guiding 4' long
	GTB13C08	2" UHMW Guiding 8' long
16	206193	Adjustable Bracket Assembly (Includes Items 1 through 13)

LLLLL = part length in inches with 2 decimal places

Length Example: Length = 35.25" LLLLL = 03525

Service parts can be obtained through your distributor or directly from Dorner Mfg. Corp. (800) 397-8664 or customerservice@dorner.com

Service Parts

#19, 39 & 49 Profile - Horizontal Adjustable Guiding

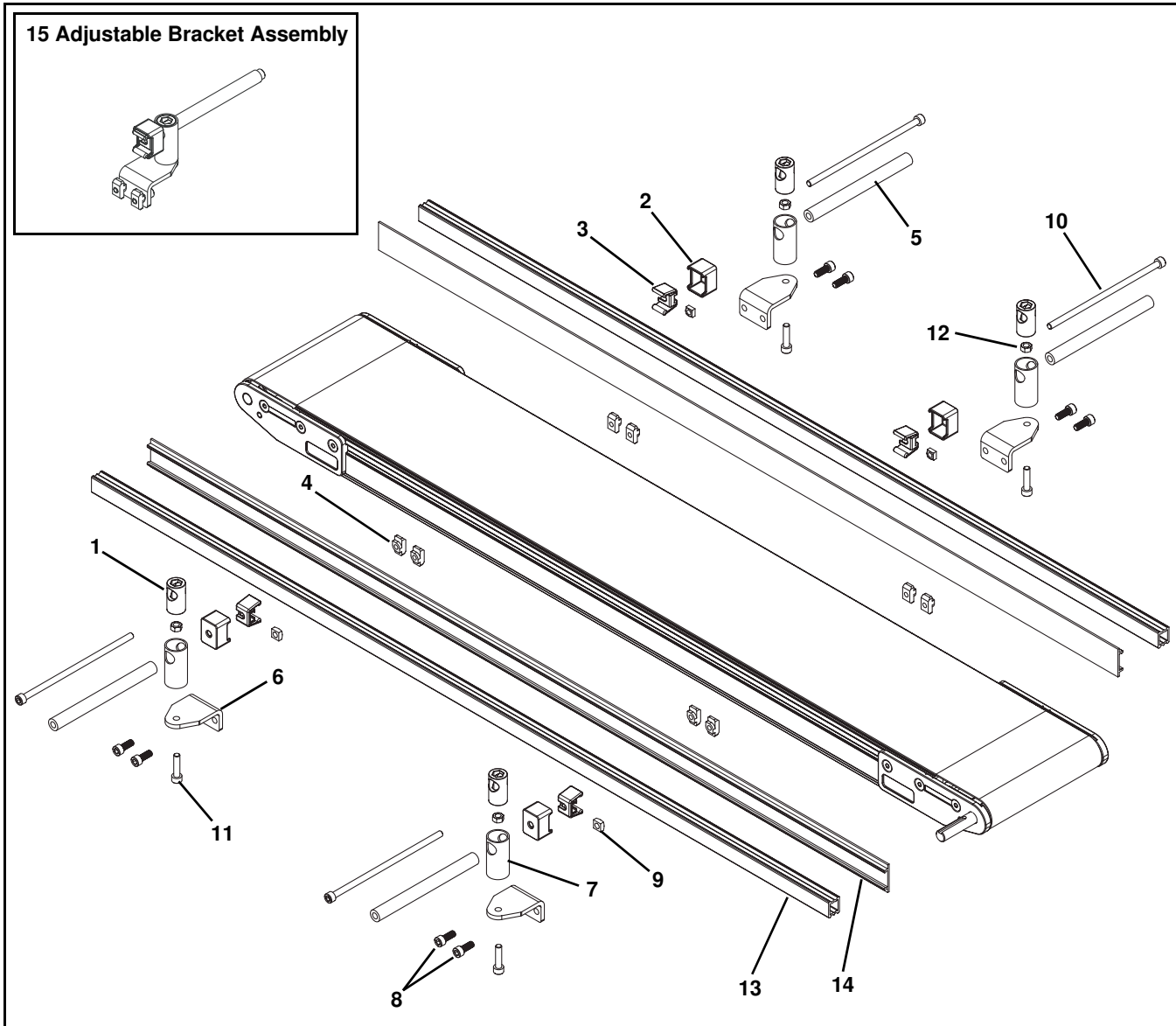

Item	Part Number	Description
1	206382	Insert Clamp
2	206383	Guide Ring
3	206397	Clip
4	206685	T-Nut
5	206692	Guide Tube
6	207146	Bracket
7	207147	Guide Tube
8	807-2859	Nylon Cap Screw, M6 x 16 mm
9	990603M	Square Nut, M6-1.0
10	9206150M	Socket Head Screw, M6-1.00 x 150 mm
11	920625M	Socket Head Screw, M6-1.00 x 25 mm
12	990601M	Hex Nut

Item	Part Number	Description
13	834-238-LLLLL	Guide Rail
	GTB13A04	Guide Rail 4' long
	GTB13A08	Guide Rail 8' long
14	834-241	1.3" UHMW Guiding (per foot)
	GTB13B04	1.3" UHMW Guiding 4' long
	GTB13B08	1.3" UHMW Guiding 8' long
	206683	2" UHMW Guiding (per foot)
	GTB13C04	2" UHMW Guiding 4' long
	GTB13C08	2" UHMW Guiding 8' long
15	207150	Adjustable Bracket Assembly (Includes Items 1 through 13)

LLLLL = part length in inches with 2 decimal places
 Length Example: Length = 35.25" LLLLL = 03525

Service parts can be obtained through your distributor or directly from Dorner Mfg. Corp. (800) 397-8664 or customerservice@dorner.com

#20, 40 & 50 Profile - Tool-Less Horizontal Adjustable Guiding

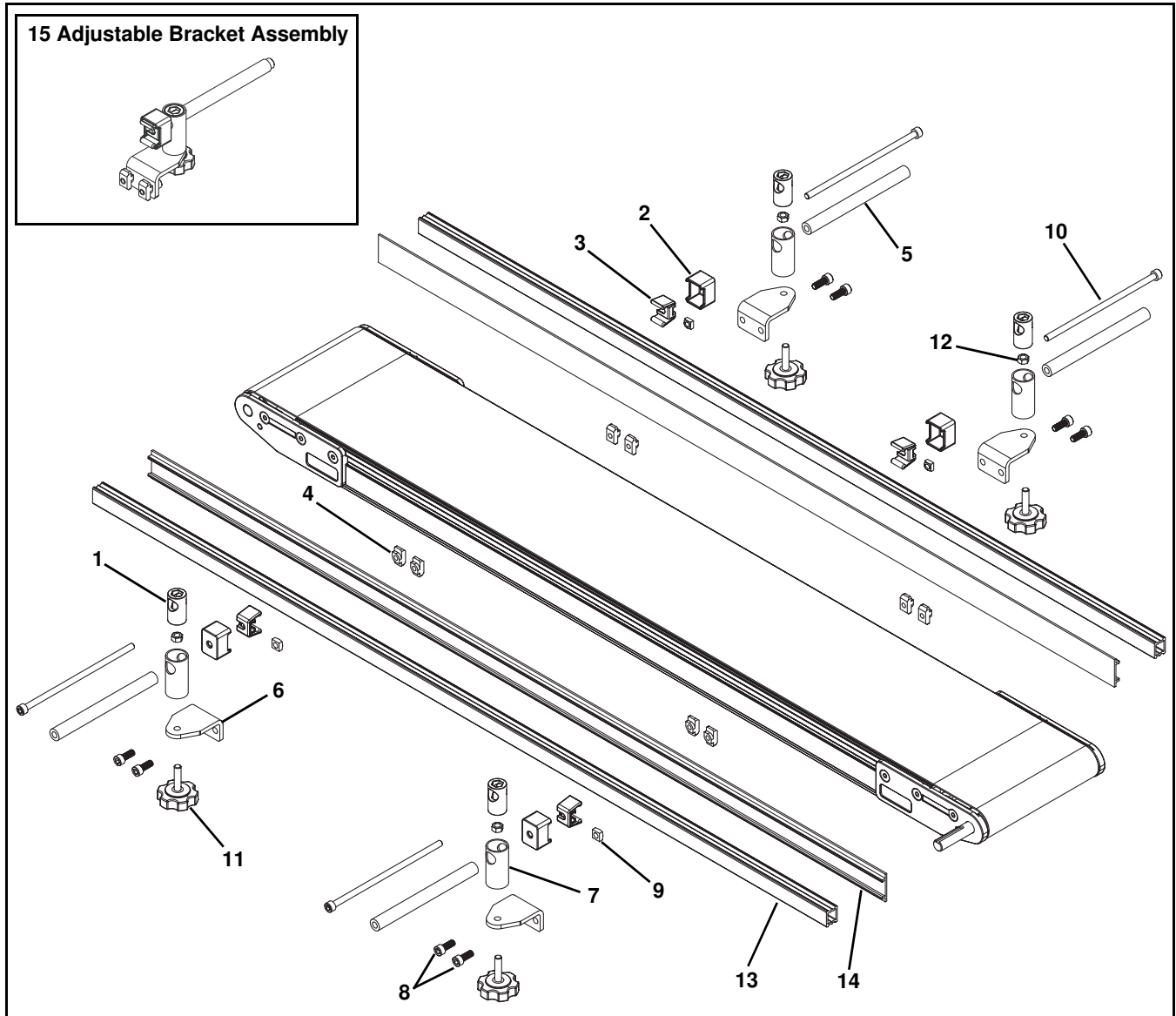

Item	Part Number	Description
1	206382	Insert Clamp
2	206383	Guide Ring
3	206397	Clip
4	206685	T-Nut
5	206692	Guide Tube
6	207146	Bracket
7	207147	Guide Tube
8	807-2859	Nylon Cap Screw, M6 x 16 mm
9	990603M	Square Nut, M6-1.0
10	9206150M	Socket Head Screw, M6-1.00 x 150 mm
11	207155	Knob
12	990601M	Hex Nut
13	834-238-LLLLL	Guide Rail
	GTB13A04	Guide Rail 4' long
	GTB13A08	Guide Rail 8' long

Item	Part Number	Description
14	834-241	1.3" UHMW Guiding (per foot)
	GTB13B04	1.3" UHMW Guiding 4' long
	GTB13B08	1.3" UHMW Guiding 8' long
	206683	2" UHMW Guiding (per foot)
	GTB13C04	2" UHMW Guiding 4' long
	GTB13C08	2" UHMW Guiding 8' long
15	207151	Tool-Less Adjustable Bracket Assembly (Includes Items 1 through 13)

LLLLL = part length in inches with 2 decimal places
 Length Example: Length = 35.25" LLLLL = 03525

Service parts can be obtained through your distributor or directly from Dorner Mfg. Corp. (800) 397-8664 or customerservice@dorner.com

Service Parts

Mounting Brackets

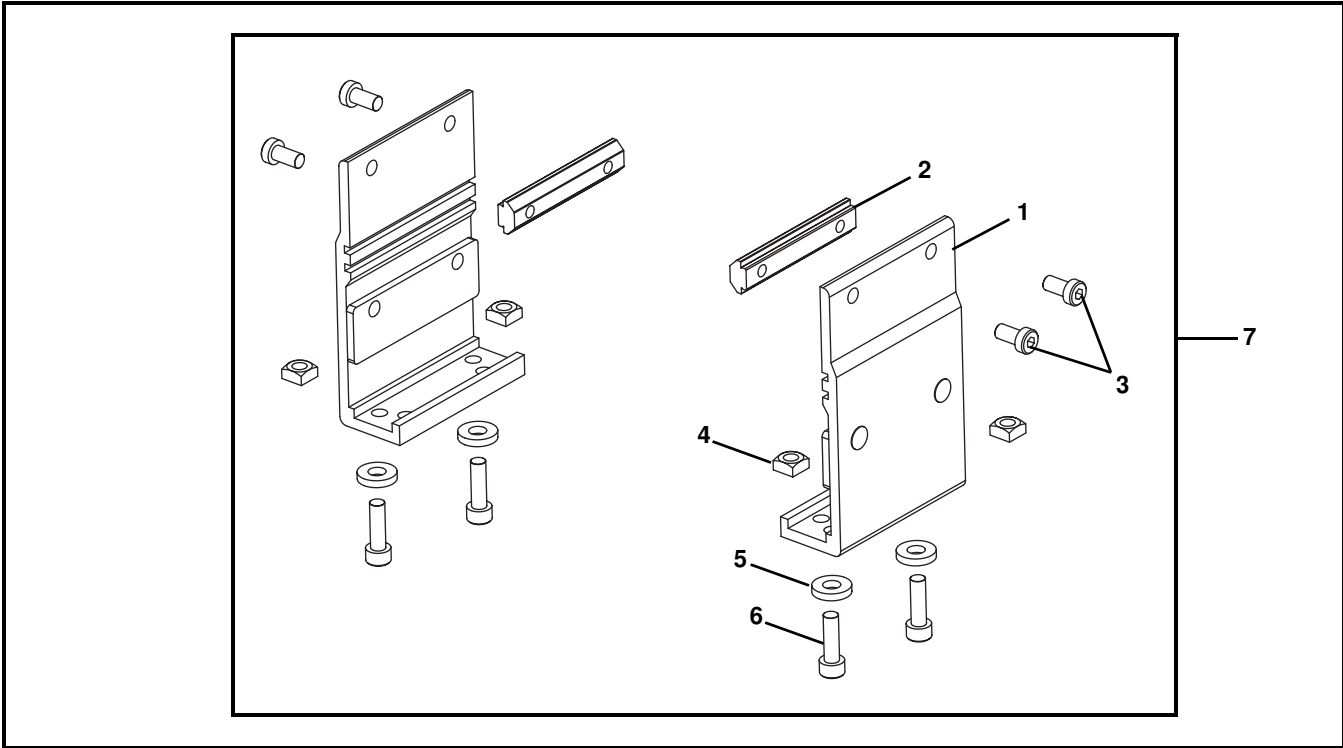

Item	Part Number	Description
1	208455	Stand Bracket Assembly
2	300150MK4	Drop-In Tee Bar (x4)
3	920692M	Low Head Cap Screw, M6-1.00 x 12 mm
4	990603M	Square Nut, M6

Item	Part Number	Description
5	605279P	Washer
6	920620M	Socket Head Screw, M6-1.00 x 20 mm
7	208427	Stand Mount Assembly

Service parts can be obtained through your distributor or directly from Dorner Mfg. Corp. (800) 397-8664 or customerservice@dorner.com

Mounting Brackets Assembled to the Tail

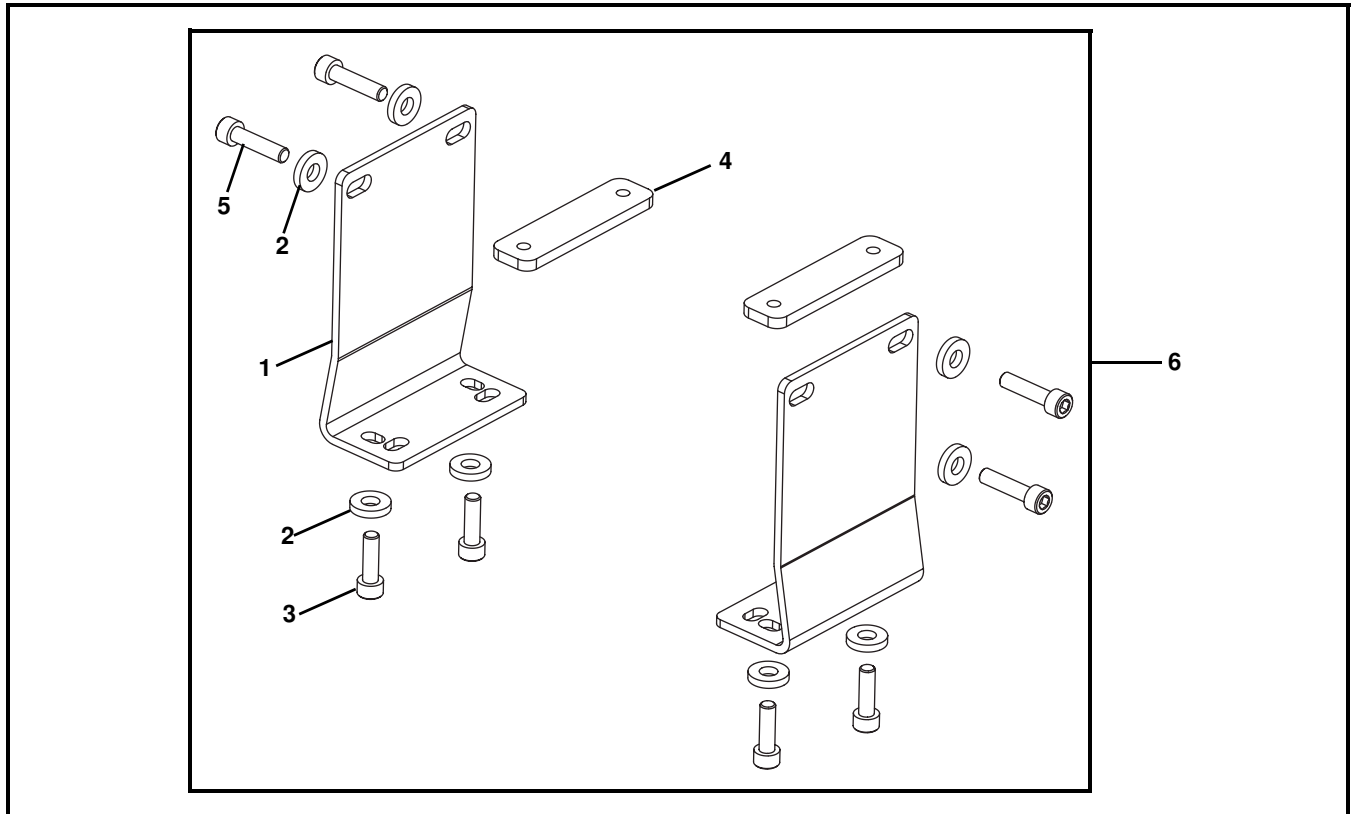

Item	Part Number	Description
1	208448	Stand Bracket
2	605279P	Washer
3	920622M	Socket Head Screw M6-1.00 x 22 mm
	920625M	Socket Head Screw M6-1.00 x 25 mm (for Nosebar Tail)
4	208470	Nut Bar
5	920625M	Socket Head Screw, M6-1.00 x 25 mm (for Idler Tail)
	920630M	Socket Head Screw, M6-1.00 x 30 mm (for Drive Tail)
	920622M	Socket Head Screw, M6-1.00 x 22 mm (for Nosebar Tail)
6	208449	Stand Mount Assembly

Service parts can be obtained through your distributor or directly from Dorner Mfg. Corp. (800) 397-8664 or customerservice@dorner.com

Service Parts

Connecting Assembly without Stand Mount

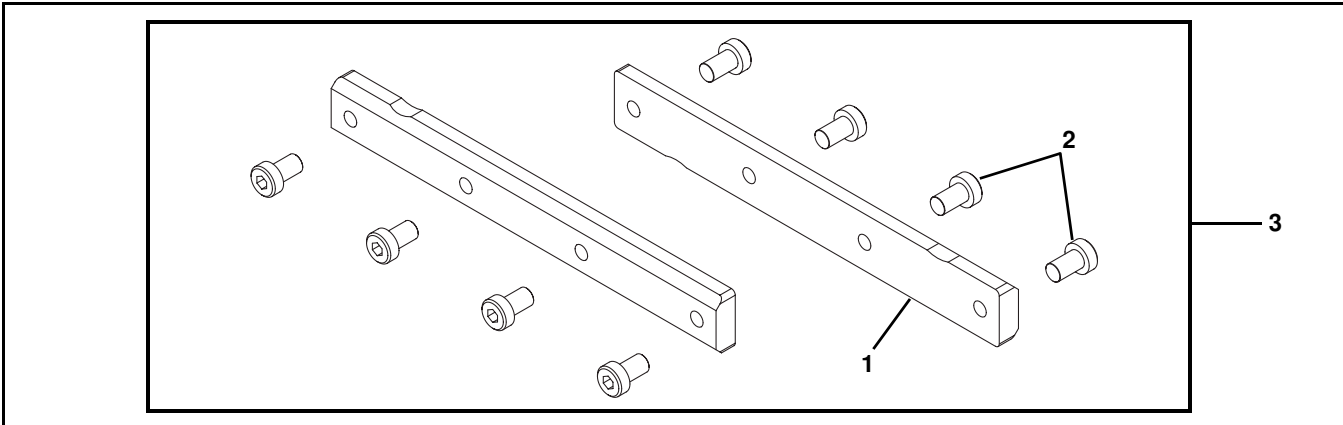

Item	Part Number	Description
1	206520	Connecting Bar
2	950610M	Low Head Cap Screw, M6-1.00 x 10 mm
3	206519	Connecting Assembly

Item	Part Number	Description
Service parts can be obtained through your distributor or directly from Dorner Mfg. Corp. (800) 397-8664 or customerservice@dorner.com		

Connecting Assembly with Stand Mount

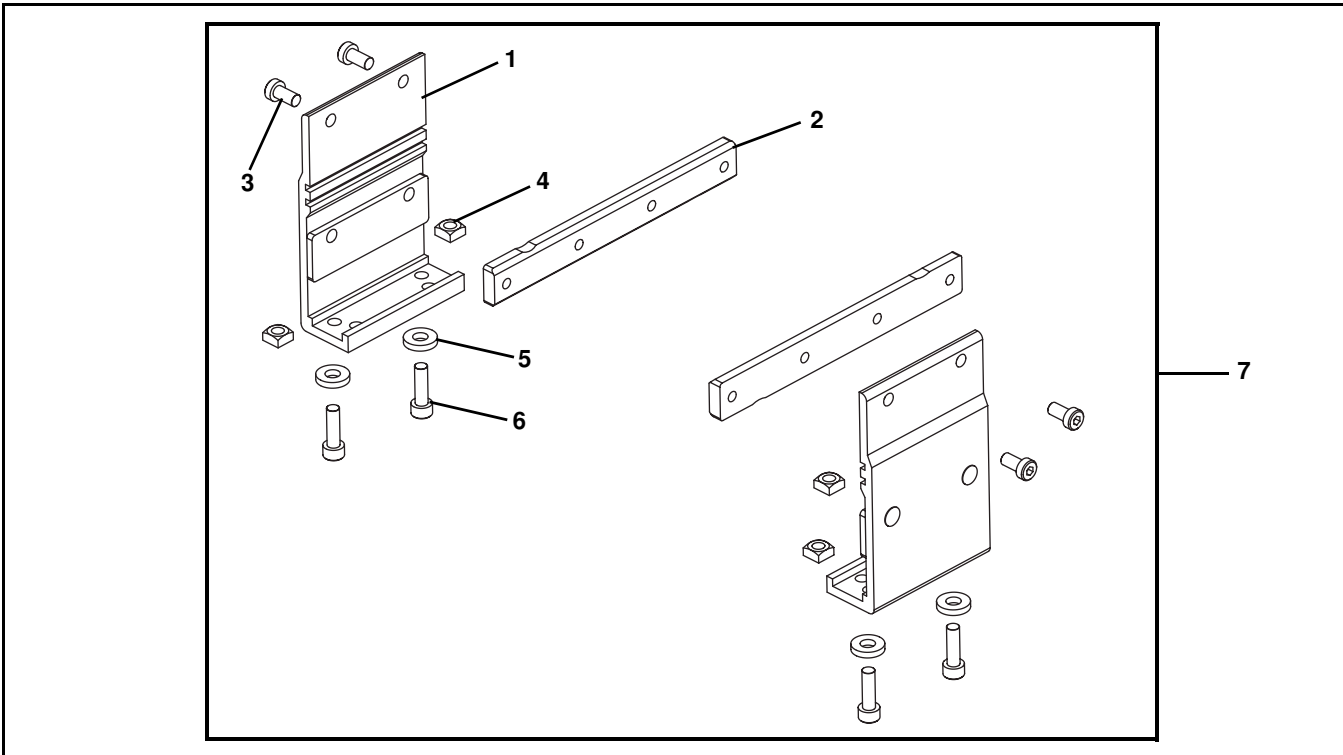

Item	Part Number	Description
1	208455	Stand Bracket Assembly
2	206520	Connecting Bar
3	920692M	Low Head Cap Screw, M6-1.00 x 12 mm
4	990603M	Square Nut, M6

Item	Part Number	Description
5	605279P	Washer
6	920620M	Socket Head Screw, M6-1.00 x 20 mm
7	208456	Connecting Assembly with Stand Mount
Service parts can be obtained through your distributor or directly from Dorner Mfg. Corp. (800) 397-8664 or customerservice@dorner.com		

Return Roller

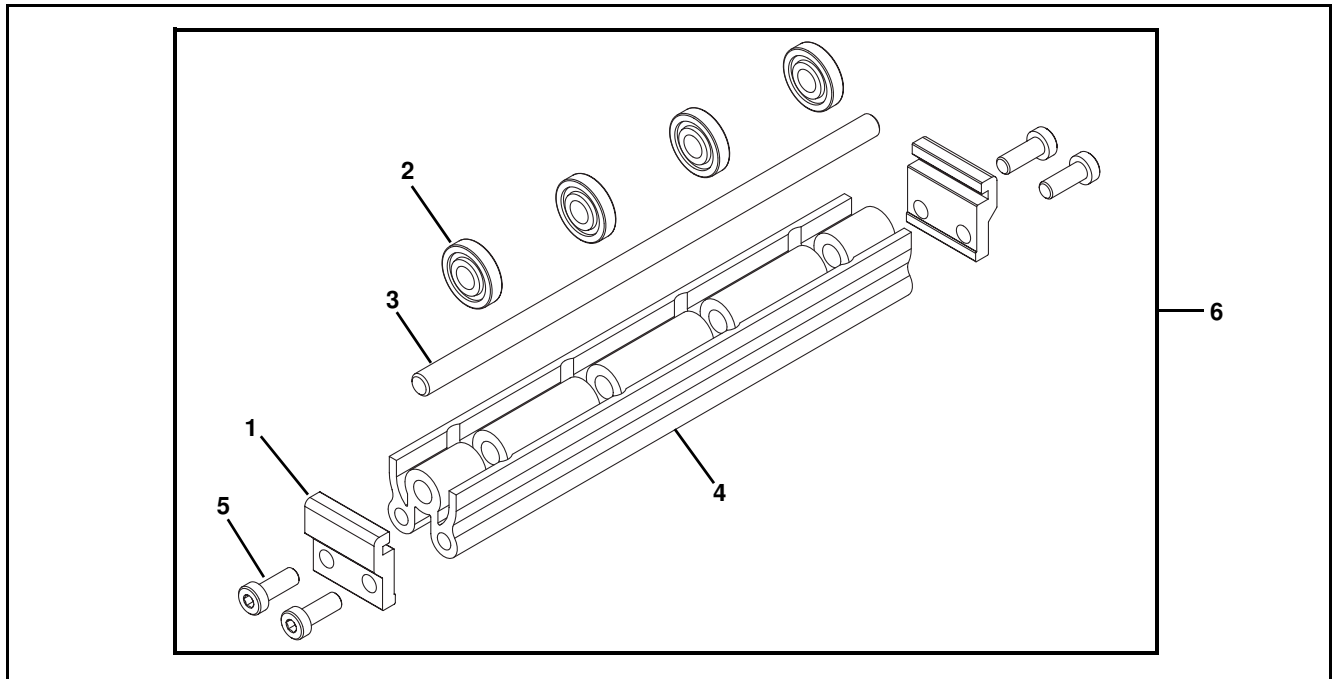

Item	Part Number	Description
1	205978	Flat Return Roller Clip
2	240826	Return Roller
3	208318- <u>WWW</u> -M	Return Roller Rod
4	208315- <u>WWW</u> -M	Return Roller Guard
5	950616M	Low Head Cap Screw, M6-1.00 x 16 mm
6	208312- <u>WWW</u> -M	Return Roller Assembly
<u>WWW</u> = Conveyor width reference: 0203 - 0914		
See Specifications chart on page 7 for conveyor belt widths.		
Service parts can be obtained through your distributor or directly from Dorner Mfg. Corp. (800) 397-8664 or customerservice@dorner.com		

Service Parts

Conveyor Belt Part Number Configuration

Flat Belt Part Number Configuration

From the model number, determine conveyor width (“WWWW”), length (“LLLLL”) and belt type (“BB”). Use data to configure belt part number as indicated below. *Add “V” for Center V-guided belts or “W” for offset V-guided belts.

22XL - WWWW LLLLL / BB V*

22XL - _____ / ____ V*
(Fill In)

Return Policy

Returns must have prior written factory authorization or they will not be accepted. Items that are returned to Dorner without authorization will not be credited nor returned to the original sender. When calling for authorization, please have the following information ready for the Dorner factory representative or your local distributor:

1. Name and address of customer.
2. Dorner part number(s) of item(s) being returned.
3. Reason for return.
4. Customer's original order number used when ordering the item(s).
5. Dorner or distributor invoice number. Include part serial number if available.

A representative will discuss action to be taken on the returned items and provide a Returned Materials Authorization (RMA) number for reference. RMA will automatically close 30 days after being issued. To get credit, items must be new and undamaged. There will be a return charge on all items returned for credit, where Dorner was not at fault. It is the customer's responsibility to prevent damage during return shipping. Damaged or modified items will not be accepted. The customer is responsible for return freight.

Product Line	Product Type								Engineered to order parts
	Standard Products								
	Conveyors	Gearmotors & Mounting Packages	Support Stands	Accessories	Spare Parts (non-belt)	Spare Belts - Standard Flat Fabric	Spare Belts - Cleated & Spec. Fabric	Spare Belts - Plastic Chain	All equipment and parts
1100 Series	30% return fee for all products except: 50% return fee for conveyors with modular belt, cleated belt or speciality belts All Electrical items are assigned original manufacturers return policy.						non-returnable		case-by-case
2200 Series									
3200 Series									
Pallet Systems									
FlexMove/SmartFlex									
GAL Series									
All Electrical									
7100 Series	50% return fee for all products						non-returnable		case-by-case
7200/7300 Series									
AquaGard 7350 Series Version 2									
GES Series									
AquaGard 7350/7360 Series	non-returnable								
AquaPruf Series	non-returnable								

Returns will not be accepted after 60 days from original invoice date. The return charge covers inspection, cleaning, disassembly, disposal and reissuing of components to inventory. If a replacement is needed prior to evaluation of returned item, a purchase order must be issued. Credit (if any) is issued only after return and evaluation is complete.

Dorner has representatives throughout the world. Contact Dorner for the name of your local representative. Our Customer Service Team will gladly help with your questions on Dorner products.

For a copy of Dorner's Warranty, contact Dorner, an authorized sales channel or visit our website: www.dorner.com.

For replacement parts, contact an authorized Dorner Service Center or the factory.

www.dorner.com



© Dorner Mfg. Corp. 2021. All Rights Reserved.

851-978 Rev. B

Printed in U.S.A.

Dorner – North & South America

Dorner – U.S.A.

Headquarters
 975 Cottonwood Ave
 Hartland, WI 53029, USA
 (800) 397-8664
 (262) 367-7600
info@dorner.com

Dorner – Canada

100-5515 North Service Road
 Burlington, Ontario L7L 6G6
 Canada
 (289) 208-7306
info@dorner.com

Dorner – Latin America

Carretera a Nogales #5297, Nave 11.
 Parque Industrial Nogales
 Zapopan, Jalisco C.P. 45222 México
 +52.33.30037400 | info.latinamerica@dorner.com

Dorner – Europe

Dorner – Germany

Karl-Heinz-Beckurts-Straße 7
 52428 Jülich,
 Germany
 +49 (0) 2461/93767-0
info.europe@dorner.com

Dorner – France

8 rue des Frères Caudron
 78140 Velizy-Villacoublay
 France
 +33 (0)1 84 73 24 27
info.france@dorner.com

Dorner – Asia

128 Jalan Permatang Damar Laut, Bayan Lepas 11960
 Penang, Malaysia
 +604-626-2948 | info.asia@dorner.com