

# METRIC JIS

Nitrided Ejector Pins - Straight.....	13
Nitrided Ejector Pins - D Head.....	14
Nitrided Ejector Step Pins.....	15
Nitrided Ejector Sleeves.....	16



Turn To The Industry Experts

## Metric JIS Nitrided Ejector Pins - Straight

- Manufactured from premium hotwork steel
- Nitrided surface reduces galling

SPECIFICATIONS	
Annealed Head	Yes
Core Hardness	40 - 45 Rc
Surface Hardness	65 - 74 Rc
Etched for Identification	Pin $\varnothing \geq 2.0$
Material Type	Hot Work Tool Steel
Unit of Measure	Metric JIS

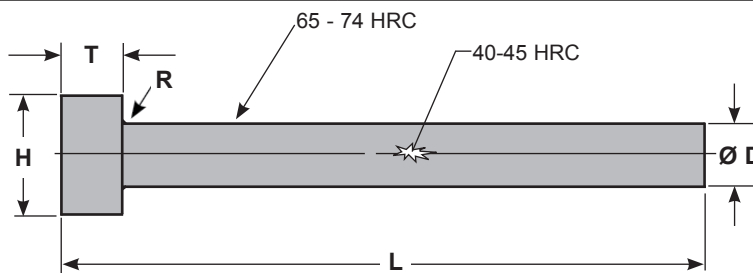

D PIN DIAMETER TOLERANCES	
JMP01 - JMP125, L < 600	-0.01 / -0.02
JMP14 - JMP20, L ≥ 600	-0.01 / -0.03

CATALOG NO.	Ø D	H +0.0 -0.2	T +0.00 -0.05	R +0.0 -0.2	L OVERALL LENGTH +2.0 / -0.0															
					100 MM	150 MM	200 MM	250 MM	300 MM	350 MM	400 MM	450 MM	500 MM	600 MM	650 MM	700 MM	800 MM	900 MM	1000 MM	
JMP01-	1.0	6	4	0.3		•														
JMP015-	1.5	6				•														
JMP02-	2.0	6				•	•	•												
JMP025-	2.5	6				•	•	•												
JMP03-	3.0	6	6	0.5		•	•	•	•	•	•	•	•							
JMP035-	3.5	7				•	•	•	•	•	•	•	•	•						
JMP04-	4.0	8				•	•	•	•	•	•	•	•	•	•					
JMP045-	4.5	8				•	•	•	•	•	•	•	•	•	•					
JMP05-	5.0	9				•	•	•	•	•	•	•	•	•	•					
JMP055-	5.5	9				•	•	•	•	•	•	•	•	•	•					
JMP06-	6.0	10				•	•	•	•	•	•	•	•	•	•	•		•	•	
JMP065-	6.5	11				•	•	•	•	•	•	•	•	•	•	•				
JMP07-	7.0	11				•	•	•	•	•	•	•	•	•	•	•	•	•	•	
JMP08-	8.0	13			8	0.5		•	•	•	•	•	•	•	•	•	•	•	•	•
JMP10-	10.0	15		•			•	•	•	•	•	•	•	•	•	•	•	•	•	•
JMP12-	12.0	17		•			•	•	•	•	•	•	•	•	•	•	•	•	•	•
JMP125-	12.5	17																		•
JMP14-	14.0	19		•			•	•	•	•	•	•	•	•	•	•	•	•	•	•
JMP15-	15.0	20		•			•	•	•	•	•	•	•	•	•	•	•	•	•	•
JMP16-	16.0	21		•			•	•	•	•	•	•	•	•	•	•	•	•	•	•
JMP18-	18.0	23		•			•	•	•	•	•	•	•	•	•	•	•	•	•	•
JMP20-	20.0	25		•			•	•	•	•	•	•	•	•	•	•	•	•	•	•

Add overall length to end of catalog number (i.e. JMP01-150)

## Metric JIS Nitrided Ejector Pins - D-Head

- Manufactured from premium hotwork steel
- Nitrided surface reduces galling



SPECIFICATIONS	
H Head Diameter Tolerance	0.0 -0.2
Actual Pin Diameter Tolerance	-0.01 -0.02
Annealed Head	Yes
L Overall Length Tolerance	2
T Head Thickness Tolerance	0.00 -0.05
Core Hardness	40 - 45 Rc
Step Tolerance	0 / +0.1
Surface Hardness	65 - 74 Rc
Etched for Identification	Yes
Material Type	Hotwork Tool Steel
Unit of Measure	Metric JIS

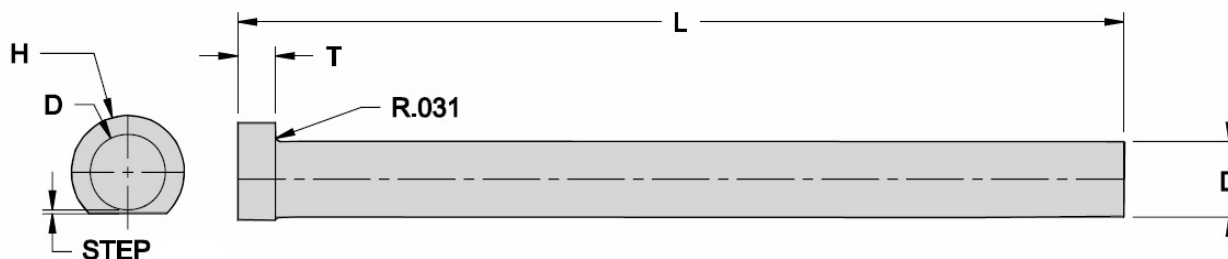

CATALOG NO.	D ACTUAL PIN DIAMETER	H HEAD DIAMETER	T HEAD THICKNESS	L OVERALL LENGTH
DJMP04-350	4	8	6	350
DJMP06-350	6	10	6	350
DJMP06-500	6	10	6	500
DJMP07-500	7	11	6	500
DJMP08-500	8	13	8	500
DJMP10-350	10	15	8	350
DJMP10-500	10	15	8	500
DJMP12-500	12	17	8	500

# Metric JIS Nitrided Step Pins

- Manufactured from premium hotwork steel
- Nitrided surface reduces galling
- Manufactured to Misumi JIS dimensions

SPECIFICATIONS	
Core Hardness	40 - 45 HRC
Surface Hardness	65 - 74 HRC
Etched for Identification	Yes
Material Type	Hotwork Tool Steel
Unit of Measure	Metric JIS

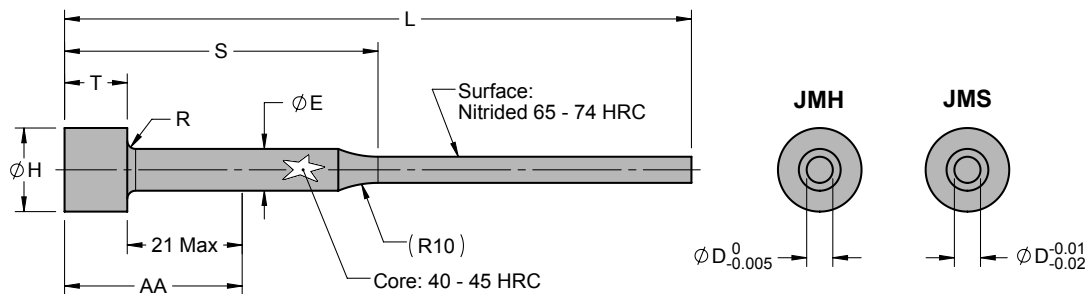

AA: Head Annealed to 30-40 HRC in This Area.

	E -0.01 -0.02	$\phi D$	H 0.0 -0.2	T 0.00 -0.05	L +2.0 -0.0	R 0.0 -0.2	CATALOG NO. S SHOULDER LENGTH -1.0 / -2.0				
							S=50	S=60	S=70	S=80	S=100
JMH	1.5	0.5	3	4	100		JMH1.5-100-0.5-60	JMH1.5-100-0.5-70			
	1.5	0.6	3	4	150		JMH1.5-150-0.6-50	JMH1.5-150-0.6-70			
	1.5	0.8	3	4	150		JMH1.5-150-0.8-50	JMH1.5-150-0.8-70			
	1.5	1.0	3	4	150			JMH1.5-150-1.0-70			
	2.5	1.2	5	4	150			JMH2.5-150-1.2-70			
	2	0.8	4	4	100	0.3	JMH2-100-0.8-50				
	2	1.0	4	4	100		JMH2-100-1.0-50				
	2	0.8	4	4	150		JMH2-150-0.8-50	JMH2-150-0.8-70			
	2	1.0	4	4	150		JMH2-150-1.0-50	JMH2-150-1.0-70			
	2	1.2	4	4	150		JMH2-150-1.2-50				
	2	1.5	4	4	150		JMH2-150-1.5-50				
	2.5	1.5	5	4	150		JMH2.5-150-1.5-50				
	3	1.0	6	4	150	0.5	JMH3-150-1.0-50	JMH3-150-1.0-70			
	3	1.2	6	4	150		JMH3-150-1.2-50				
3	1.5	6	4	150	JMH3-150-1.5-50						
3	1.5	6	4	150	JMH3-150-2.0-50		JMH3-150-2.0-70				
3	1.5	6	4	200			JMH3-200-1.5-70	JMH3-200-1.5-80	JMH3-200-1.5-100		
3	2.0	6	4	200					JMH3-200-2.0-100		
JMS	2	1.0	4	4	150	0.3	JMS2-150-1.0-50	JMS2-150-1.0-70			
	2	1.2	4	4	150		JMS2-150-1.2-50	JMS2-150-1.2-70			
	2	1.5	4	4	150		JMS2-150-1.5-50	JMS2-150-1.5-70			
	2.5	1.5	5	4	150		JMS2.5-150-1.5-50				
	3	1.5	6	4	150	JMS3-150-1.5-50					
	3	2.0	6	4	150	JMS3-150-2.0-50	JMS3-150-2.0-70				
	3	1.0	6	4	200			JMS3-200-1.0-80			
	3	1.5	6	4	200		JMS3-200-1.5-70	JMS3-200-1.5-80	JMS3-200-1.5-100		
	3	2.0	6	4	200			JMS3-200-2.0-80			
	3	1.0	6	4	150	0.5	JMS3-150-1.0-50				
	3	1.0	6	4	200		JMS3-150-1.2-50				
	3	1.2	6	4	200			JMS3-200-1.2-70			
	3	1.5	6	4	150		JMS3-150-1.5-50				
	4	2.0	8	6	200				JMS4-150-2.0-80		
	4	2.0	8	6	200			JMS4-200-2.0-70			
	4	2.5	8	6	150		JMS4-150-2.5-50				
4	2.5	8	6	150			JMS4-200-2.5-70				

## Metric JIS Nitrided Ejector Sleeves

- Manufactured from premium hotwork steel
- Nitrided surface reduces galling
- Manufactured to Misumi JIS metric specifications



SPECIFICATIONS	
Core Hardness	37 - 43 HRC
Surface Hardness	65 - 74 Rc
Etched for Identification	Yes
Material Type	Hot Work Tool Steel
Unit of Measure	Metric JIS

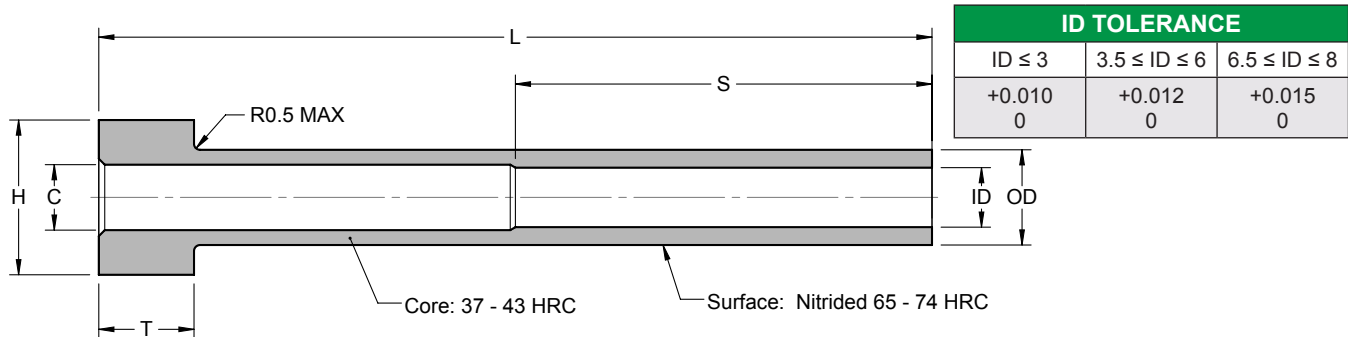

ID	OD -0.01 -0.02	H +0.0 -0.3	T +0.00 -0.05	C +/-0.1	CATALOG NO.					
					L = LENGTH +5.0 / +0.1					
					S = 50	S = 50	S = 50	S = 75	S = 75	S = 75
					100	120	140	160	180	200
2.5	4	8	6	3	JES-25-4-100	JES-25-4-120	JES-25-4-140	JES-25-4-160	JES-25-4-180	JES-25-4-200
2.5	4.5	8	6	3	JES-25-45-100	JES-25-45-120	JES-25-45-140	JES-25-45-160	JES-25-45-180	JES-25-45-200
2.5	5	9	6	3	JES-25-5-100	JES-25-5-120	JES-25-5-140	JES-25-5-160	JES-25-5-180	JES-25-5-200
2.5	5.5	9	6	3	JES-25-55-100	JES-25-55-120	JES-25-55-140	JES-25-55-160	JES-25-55-180	JES-25-55-200
2.5	6	10	6	3	JES-25-6-100	JES-25-6-120	JES-25-6-140	JES-25-6-160	JES-25-6-180	JES-25-6-200
2.5	6.5	11	6	3	JES-25-65-100	JES-25-65-120	JES-25-65-140	JES-25-65-160	JES-25-65-180	JES-25-65-200
2.5	7	11	6	3	JES-25-7-100	JES-25-7-120	JES-25-7-140	JES-25-7-160	JES-25-7-180	JES-25-7-200
2.5	8	13	8	3	JES-25-8-100	JES-25-8-120	JES-25-8-140	JES-25-8-160	JES-25-8-180	JES-25-8-200
3	5	9	6	3.5	JES-3-5-100	JES-3-5-120	JES-3-5-140	JES-3-5-160	JES-3-5-180	JES-3-5-200
3	5.5	9	6	3.5	JES-3-55-100	JES-3-55-120	JES-3-55-140	JES-3-55-160	JES-3-55-180	JES-3-55-200
3	6	10	6	3.5	JES-3-6-100	JES-3-6-120	JES-3-6-140	JES-3-6-160	JES-3-6-180	JES-3-6-200
3	6.5	11	6	3.5	JES-3-65-100	JES-3-65-120	JES-3-65-140	JES-3-65-160	JES-3-65-180	JES-3-65-200
3	7	11	6	3.5	JES-3-7-100	JES-3-7-120	JES-3-7-140	JES-3-7-160	JES-3-7-180	JES-3-7-200
3	7.5	12	6	3.5	JES-3-75-100	JES-3-75-120	JES-3-75-140	JES-3-75-160	JES-3-75-180	JES-3-75-200
3	8	13	8	3.5	JES-3-8-100	JES-3-8-120	JES-3-8-140	JES-3-8-160	JES-3-8-180	JES-3-8-200
3.5	6	10	6	4	JES-35-6-100	JES-35-6-120	JES-35-6-140	JES-35-6-160	JES-35-6-180	JES-35-6-200
3.5	6.5	11	6	4	JES-35-65-100	JES-35-65-120	JES-35-65-140	JES-35-65-160	JES-35-65-180	JES-35-65-200
3.5	7	11	6	4	JES-35-7-100	JES-35-7-120	JES-35-7-140	JES-35-7-160	JES-35-7-180	JES-35-7-200
3.5	7.5	12	6	4	JES-35-75-100	JES-35-75-120	JES-35-75-140	JES-35-75-160	JES-35-75-180	JES-35-75-200
3.5	8	13	8	4	JES-35-8-100	JES-35-8-120	JES-35-8-140	JES-35-8-160	JES-35-8-180	JES-35-8-200
4	6	10	6	4.5	JES-4-6-100	JES-4-6-120	JES-4-6-140	JES-4-6-160	JES-4-6-180	JES-4-6-200
4	6.5	11	6	4.5	JES-4-65-100	JES-4-65-120	JES-4-65-140	JES-4-65-160	JES-4-65-180	JES-4-65-200

Continued on next page

## Metric JIS Nitrided Ejector Sleeves

- Manufactured from premium hotwork steel
- Nitrided surface reduces galling
- Manufactured to Misumi JIS metric specifications

SPECIFICATIONS	
Core Hardness	37 - 43 HRC
Surface Hardness	65 - 74 Rc
Etched for Identification	Yes
Material Type	Hot Work Tool Steel
Unit of Measure	Metric JIS

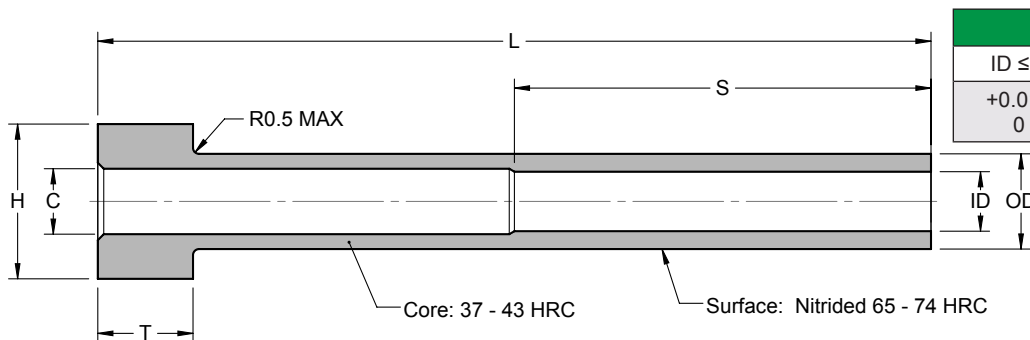

ID TOLERANCE		
ID ≤ 3	3.5 ≤ ID ≤ 6	6.5 ≤ ID ≤ 8
+0.010 0	+0.012 0	+0.015 0

ID	OD -0.01 -0.02	H +0.0 -0.3	T +0.00 -0.05	C +/-0.1	CATALOG NO.					
					L = LENGTH +5.0 / +0.1					
					S = 50 100	S = 50 120	S = 50 140	S = 50 160	S = 75 180	S = 75 200
4	7	11	6	4.5	JES-4-7-100	JES-4-7-120	JES-4-7-140	JES-4-7-160	JES-4-7-180	JES-4-7-200
4	7.5	12	6	4.5	JES-4-7.5-100	JES-4-7.5-120	JES-4-7.5-140	JES-4-7.5-160	JES-4-7.5-180	JES-4-7.5-200
4	8	13	8	4.5	JES-4-8-100	JES-4-8-120	JES-4-8-140	JES-4-8-160	JES-4-8-180	JES-4-8-200
4	10	15	8	4.5	JES-4-10-100	JES-4-10-120	JES-4-10-140	JES-4-10-160	JES-4-10-180	JES-4-10-200
4	12	17	8	4.5	JES-4-12-100	JES-4-12-120	JES-4-12-140	JES-4-12-160		JES-4-12-200
4.5	7	11	6	5	JES-4.5-7-100	JES-4.5-7-120	JES-4.5-7-140	JES-4.5-7-160	JES-4.5-7-180	JES-4.5-7-200
4.5	7.5	12	6	5	JES-4.5-7.5-100	JES-4.5-7.5-120	JES-4.5-7.5-140	JES-4.5-7.5-160	JES-4.5-7.5-180	JES-4.5-7.5-200
4.5	8	13	8	5	JES-4.5-8-100	JES-4.5-8-120	JES-4.5-8-140	JES-4.5-8-160	JES-4.5-8-180	JES-4.5-8-200
4.5	10	15	8	5	JES-4.5-10-100	JES-4.5-10-120	JES-4.5-10-140	JES-4.5-10-160	JES-4.5-10-180	JES-4.5-10-200
4.5	12	17	8	5	JES-4.5-12-100	JES-4.5-12-120	JES-4.5-12-140	JES-4.5-12-160	JES-4.5-12-180	JES-4.5-12-200
5	8	13	8	5.5	JES-5-8-100	JES-5-8-120	JES-5-8-140	JES-5-8-160	JES-5-8-180	JES-5-8-200
5	10	15	8	5.5	JES-5-10-100	JES-5-10-120	JES-5-10-140	JES-5-10-160	JES-5-10-180	JES-5-10-200
5	12	17	8	5.5	JES-5-12-100	JES-5-12-120	JES-5-12-140	JES-5-12-160	JES-5-12-180	JES-5-12-200
5.5	10	15	8	6	JES-5.5-10-100	JES-5.5-10-120	JES-5.5-10-140	JES-5.5-10-160	JES-5.5-10-180	JES-5.5-10-200
5.5	12	17	8	6	JES-5.5-12-100	JES-5.5-12-120	JES-5.5-12-140	JES-5.5-12-160	JES-5.5-12-180	JES-5.5-12-200
6	10	15	8	6.5	JES-6-10-100	JES-6-10-120	JES-6-10-140	JES-6-10-160	JES-6-10-180	JES-6-10-200
6	12	17	8	6.5	JES-6-12-100	JES-6-12-120	JES-6-12-140	JES-6-12-160	JES-6-12-180	JES-6-12-200
6.5	10	15	8	7	JES-6.5-10-100	JES-6.5-10-120	JES-6.5-10-140	JES-6.5-10-160	JES-6.5-10-180	JES-6.5-10-200
6.5	12	17	8	7	JES-6.5-12-100	JES-6.5-12-120	JES-6.5-12-140	JES-6.5-12-160	JES-6.5-12-180	JES-6.5-12-200
7	12	17	8	7.5	JES-7-12-100	JES-7-12-120	JES-7-12-140	JES-7-12-160	JES-7-12-180	JES-7-12-200
8	12	17	8	8.5	JES-8-12-100	JES-8-12-120	JES-8-12-140	JES-8-12-160	JES-8-12-180	JES-8-12-200

Continued on next page

## Metric JIS Nitrided Ejector Sleeves

- Manufactured from premium hotwork steel
- Nitrided surface reduces galling
- Manufactured to Misumi JIS metric specifications



SPECIFICATIONS	
Core Hardness	37 - 43 HRC
Surface Hardness	65 - 74 Rc
Etched for Identification	Yes
Material Type	Hot Work Tool Steel
Unit of Measure	Metric JIS

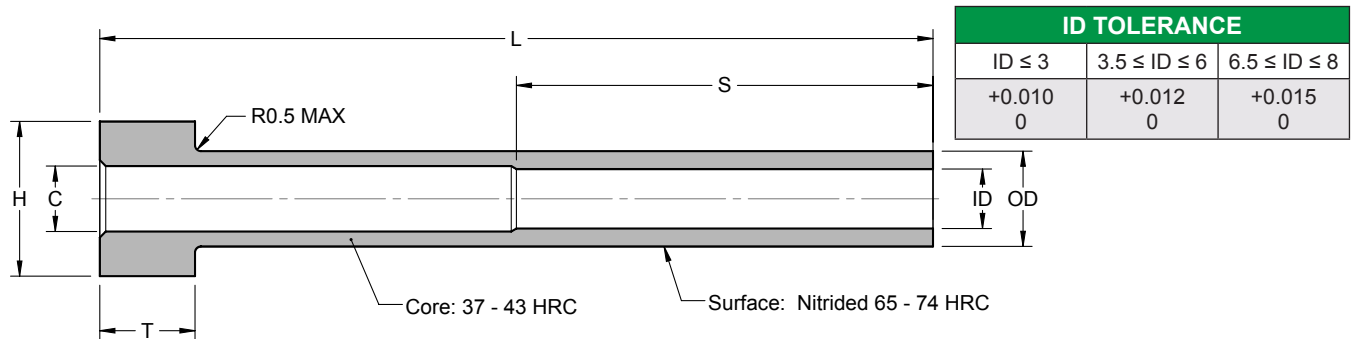

ID	OD -0.01 -0.02	H +0.0 -0.3	T +0.00 -0.05	C +/-0.1	CATALOG NO.					
					L = LENGTH +5.0 / +0.1					
					S = 100	S = 100	S = 100	S = 115	S = 115	S = 115
					225	250	275	300	325	350
2.5	5	9	6	3	JES-25-5-225					
2.5	5.5	9	6	3	JES-25-55-225					
2.5	6	10	6	3	JES-25-6-225	JES-25-6-250	JES-25-6-275	JES-25-6-300		
2.5	6.5	11	6	3	JES-25-65-225	JES-25-65-250	JES-25-65-275	JES-25-65-300		
2.5	7	11	6	3	JES-25-7-225	JES-25-7-250	JES-25-7-275	JES-25-7-300		
2.5	8	13	8	3	JES-25-8-225	JES-25-8-250	JES-25-8-275	JES-25-8-300		
3	5	9	6	3.5	JES-3-5-225	JES-3-5-250	JES-3-5-275	JES-3-5-300		
3	5.5	9	6	3.5	JES-3-55-225	JES-3-55-250	JES-3-55-275	JES-3-55-300		
3	6	10	6	3.5	JES-3-6-225	JES-3-6-250	JES-3-6-275	JES-3-6-300	JES-3-6-325	JES-3-6-350
3	6.5	11	6	3.5	JES-3-65-225	JES-3-65-250	JES-3-65-275	JES-3-65-300	JES-3-65-325	JES-3-65-350
3	7	11	6	3.5	JES-3-7-225	JES-3-7-250	JES-3-7-275	JES-3-7-300	JES-3-7-325	JES-3-7-350
3	7.5	12	6	3.5	JES-3-75-225	JES-3-75-250	JES-3-75-275	JES-3-75-300		
3	8	13	8	3.5	JES-3-8-225	JES-3-8-250	JES-3-8-275	JES-3-8-300	JES-3-8-325	JES-3-8-350
3.5	6	10	6	4	JES-35-6-225	JES-35-6-250	JES-35-6-275	JES-35-6-300	JES-35-6-325	JES-35-6-350
3.5	6.5	11	6	4	JES-35-65-225	JES-35-65-250	JES-35-65-275	JES-35-65-300	JES-35-65-325	JES-35-65-350
3.5	7	11	6	4	JES-35-7-225	JES-35-7-250	JES-35-7-275	JES-35-7-300	JES-35-7-325	JES-35-7-350
3.5	7.5	12	6	4	JES-35-75-225	JES-35-75-250	JES-35-75-275	JES-35-75-300	JES-35-75-325	JES-35-75-350
3.5	8	13	8	4	JES-35-8-225	JES-35-8-250	JES-35-8-275	JES-35-8-300	JES-35-8-325	JES-35-8-350
4	6	11	6	4.5	JES-4-6-225	JES-4-6-250	JES-4-6-275	JES-4-6-300		
4	6.5	11	6	4.5	JES-4-65-225	JES-4-65-250	JES-4-65-275	JES-4-65-300	JES-4-65-325	JES-4-65-350

Continued on next page



## Metric JIS Nitrided Ejector Sleeves

- Manufactured from premium hotwork steel
- Nitrided surface reduces galling
- Manufactured to Misumi JIS metric specifications

SPECIFICATIONS	
Core Hardness	37 - 43 HRC
Surface Hardness	65 - 74 Rc
Etched for Identification	Yes
Material Type	Hot Work Tool Steel
Unit of Measure	Metric JIS

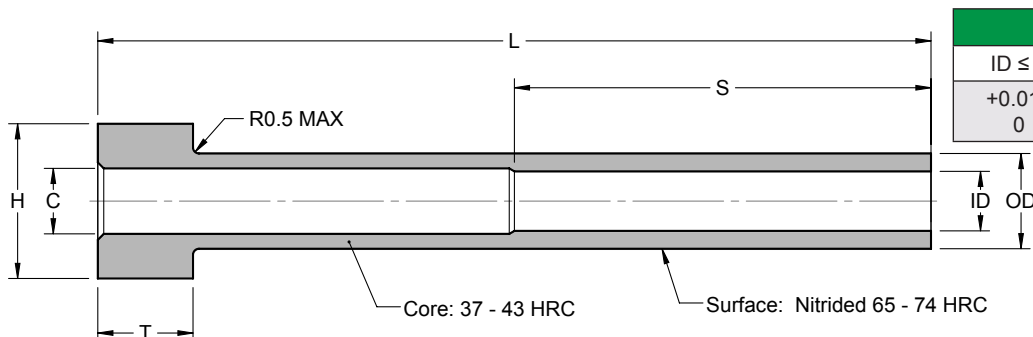

ID TOLERANCE		
ID ≤ 3	3.5 ≤ ID ≤ 6	6.5 ≤ ID ≤ 8
+0.010 0	+0.012 0	+0.015 0

ID	OD -0.01 -0.02	H +0.0 -0.3	T +0.00 -0.05	C +/-0.1	CATALOG NO.					
					L = LENGTH +5.0 / +0.1					
					S = 100 225	S = 100 250	S = 100 275	S = 115 300	S = 115 325	S = 115 350
4	7	11	6	4.5	JES-4-7-225	JES-4-7-250	JES-4-7-275	JES-4-7-300	JES-4-7-325	JES-4-7-350
4	7.5	12	6	4.5	JES-4-75-225	JES-4-75-250	JES-4-75-275	JES-4-75-300	JES-4-75-325	JES-4-75-350
4	8	13	8	4.5	JES-4-8-225	JES-4-8-250	JES-4-8-275	JES-4-8-300	JES-4-8-325	JES-4-8-350
4	10	15	8	4.5	JES-4-10-225	JES-4-10-250	JES-4-10-275	JES-4-10-300	JES-4-10-325	JES-4-10-350
4	12	17	8	4.5	JES-4-12-225	JES-4-12-250	JES-4-12-275	JES-4-12-300	JES-4-12-325	JES-4-12-350
4.5	7	11	6	5	JES-45-7-225	JES-45-7-250	JES-45-7-275	JES-45-7-300	JES-45-7-325	JES-45-7-350
4.5	7.5	12	6	5	JES-45-75-225	JES-45-75-250	JES-45-75-275	JES-45-75-300	JES-45-75-325	JES-45-75-350
4.5	8	13	8	5	JES-45-8-225	JES-45-8-250	JES-45-8-275	JES-45-8-300	JES-45-8-325	JES-45-8-350
4.5	10	15	8	5	JES-45-10-225	JES-45-10-250	JES-45-10-275	JES-45-10-300	JES-45-10-325	JES-45-10-350
4.5	12	17	8	5	JES-45-12-225	JES-45-12-250	JES-45-12-275	JES-45-12-300	JES-45-12-325	JES-45-12-350
5	8	13	8	5.5	JES-5-8-225	JES-5-8-250	JES-5-8-275	JES-5-8-300	JES-5-8-325	JES-5-8-350
5	10	15	8	5.5	JES-5-10-225	JES-5-10-250	JES-5-10-275	JES-5-10-300	JES-5-10-325	JES-5-10-350
5	12	17	8	5.5	JES-5-12-225	JES-5-12-250	JES-5-12-275	JES-5-12-300	JES-5-12-325	JES-5-12-350
5.5	10	15	8	6	JES-55-10-225	JES-55-10-250	JES-55-10-275	JES-55-10-300	JES-55-10-325	JES-55-10-350
5.5	12	17	8	6	JES-55-12-225	JES-55-12-250	JES-55-12-275	JES-55-12-300	JES-55-12-325	JES-55-12-350
6	10	15	8	6.5	JES-6-10-225	JES-6-10-250	JES-6-10-275	JES-6-10-300	JES-6-10-325	JES-6-10-350
6	12	17	8	6.5	JES-6-12-225	JES-6-12-250	JES-6-12-275	JES-6-12-300	JES-6-12-325	JES-6-12-350
6.5	10	15	8	7	JES-65-10-225	JES-65-10-250	JES-65-10-275	JES-65-10-300	JES-65-10-325	JES-65-10-350
6.5	12	17	8	7	JES-65-12-225	JES-65-12-250	JES-65-12-275	JES-65-12-300	JES-65-12-325	JES-65-12-350
7	12	17	8	7.5	JES-7-12-225	JES-7-12-250	JES-7-12-275	JES-7-12-300	JES-7-12-325	JES-7-12-350
8	12	17	8	8.5	JES-8-12-225	JES-8-12-250	JES-8-12-275	JES-8-12-300	JES-8-12-325	JES-8-12-350

Continued on next page

## Metric JIS Nitrided Ejector Sleeves

- Manufactured from premium hotwork steel
- Nitrided surface reduces galling
- Manufactured to Misumi JIS metric specifications



SPECIFICATIONS	
Core Hardness	37 - 43 HRC
Surface Hardness	65 - 74 Rc
Etched for Identification	Yes
Material Type	Hot Work Tool Steel
Unit of Measure	Metric JIS

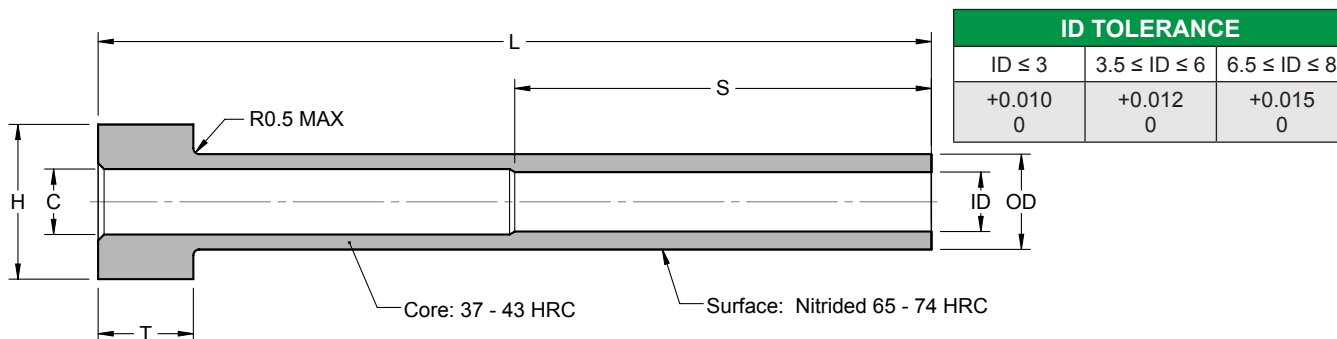

ID	OD -0.01 -0.02	H +0.0 -0.3	T +0.00 -0.05	C +/-0.1	CATALOG NO.			
					L = LENGTH +5.0 / +0.1			
					S = 150	S = 150	S = 150	S = 150
					375	400	425	450
3	6	10	6	3.5	JES-3-6-375	JES-3-6-400	JES-3-6-425	JES-3-6-450
3	6.5	11	6	3.5	JES-3-65-375	JES-3-65-400	JES-3-65-425	JES-3-65-450
3	7	11	6	3.5	JES-3-7-375	JES-3-7-400	JES-3-7-425	JES-3-7-450
3	8	13	8	3.5	JES-3-8-375	JES-3-8-400	JES-3-8-425	JES-3-8-450
3.5	6	10	6	4	JES-35-6-375	JES-35-6-400	JES-35-6-425	JES-35-6-450
3.5	6.5	11	6	4	JES-35-65-375	JES-35-65-400	JES-35-65-425	JES-35-65-450
3.5	7	11	6	4	JES-35-7-375	JES-35-7-400	JES-35-7-425	JES-35-7-450
3.5	7.5	12	6	4	JES-35-75-375			
3.5	8	13	8	4	JES-35-8-375	JES-35-8-400	JES-35-8-425	JES-35-8-450
4	7	11	6	4.5	JES-4-7-375	JES-4-7-400	JES-4-7-425	JES-4-7-450
4	6.5	11	6	4.5	JES-4-65-375	JES-4-65-400	JES-4-65-425	JES-4-65-450
4	7.5	12	6	4.5	JES-4-75-375			
4	8	13	8	4.5	JES-4-8-375	JES-4-8-400	JES-4-8-425	JES-4-8-450
4	10	15	8	4.5	JES-4-10-375	JES-4-10-400	JES-4-10-425	JES-4-10-450
4	12	17	8	4.5	JES-4-12-375	JES-4-12-400	JES-4-12-425	JES-4-12-450
4.5	7	11	6	5	JES-45-7-375	JES-45-7-400	JES-45-7-425	
4.5	7.5	12	6	5	JES-45-75-375			
4.5	8	13	8	5	JES-45-8-375	JES-45-8-400	JES-45-8-425	JES-45-8-450
4.5	10	15	8	5	JES-45-10-375	JES-45-10-400	JES-45-10-425	JES-45-10-450
4.5	12	17	8	5	JES-45-12-375	JES-45-12-400	JES-45-12-425	JES-45-12-450

Continued on next page

## Metric JIS Nitrided Ejector Sleeves

- Manufactured from premium hotwork steel
- Nitrided surface reduces galling
- Manufactured to Misumi JIS metric specifications

SPECIFICATIONS	
Core Hardness	37 - 43 HRC
Surface Hardness	65 - 74 Rc
Etched for Identification	Yes
Material Type	Hot Work Tool Steel
Unit of Measure	Metric JIS

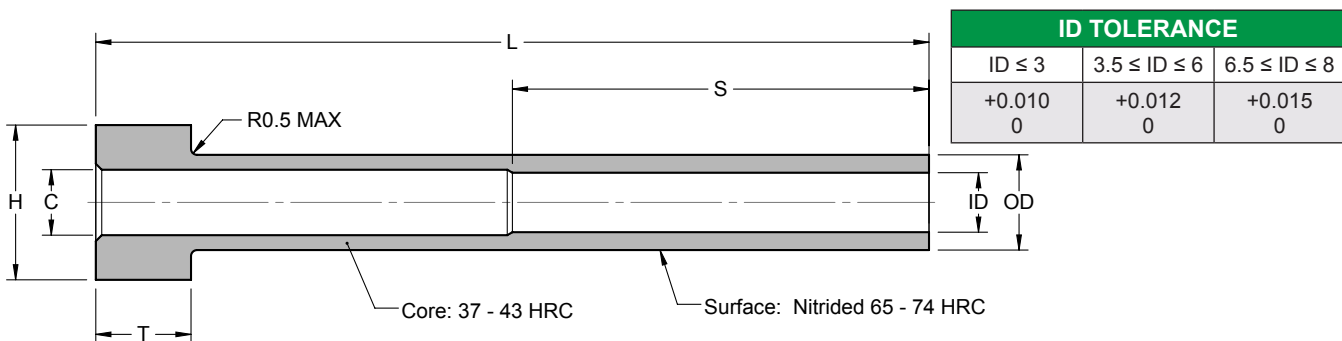

ID	OD -0.01 -0.02	H +0.0 -0.3	T +0.00 -0.05	C +/-0.1	CATALOG NO.					
					L = LENGTH +5.0 / +0.1					
					S = 150	S = 150	S = 150	S = 150	S = 150	S = 150
					375	400	425	450	475	500
5	8	13	8	5.5	JES-5-8-375	JES-5-8-400	JES-5-8-425	JES-5-8-450	JES-5-8-475	JES-5-8-500
5	10	15	8	5.5	JES-5-10-375	JES-5-10-400	JES-5-10-425	JES-5-10-450	JES-5-10-475	JES-5-10-500
5	12	17	8	5.5	JES-5-12-375	JES-5-12-400	JES-5-12-425	JES-5-12-450	JES-5-12-475	JES-5-12-500
5.5	10	15	8	6	JES-55-10-375	JES-55-10-400	JES-55-10-425	JES-55-10-450	JES-55-10-475	JES-55-10-500
5.5	12	17	8	6	JES-55-12-375	JES-55-12-400	JES-55-12-425	JES-55-12-450	JES-55-12-475	JES-55-12-500
6	10	15	8	6.5	JES-6-10-375	JES-6-10-400	JES-6-10-425	JES-6-10-450	JES-6-10-475	JES-6-10-500
6	12	17	8	6.5	JES-6-12-375	JES-6-12-400	JES-6-12-425	JES-6-12-450	JES-6-12-475	JES-6-12-500
6.5	10	15	8	7	JES-65-10-375	JES-65-10-400	JES-65-10-425	JES-65-10-450	JES-65-10-475	JES-65-10-500
6.5	12	17	8	7	JES-65-12-375	JES-65-12-400	JES-65-12-425	JES-65-12-450	JES-65-12-475	JES-65-12-500
7	12	17	8	7.5	JES-7-12-375	JES-7-12-400	JES-7-12-425	JES-7-12-450	JES-7-12-475	JES-7-12-500
8	12	17	8	8.5	JES-8-12-375	JES-8-12-400	JES-8-12-425	JES-8-12-450	JES-8-12-475	JES-8-12-500