



READY

THE INNOVATOR OF OUR INDUSTRY[®]

READY Benders[®]

A Unique Off-the-shelf Forming Tool

READY Is Proud to Offer Its Enhanced Line of Patented READY Benders®



Clamp - contact



Bend - midstroke



Overbend - die closed

Precise Rotary Forming Motion

- "Benders" transfer the vertical movement of any press into a precise, rotary forming motion. This allows the bender to easily overbend past 90° to counter material springback, a distinct mechanical advantage.
- READY Benders® give tool designers and metal stampers a way to produce tooling that holds consistent part angle tolerances, especially when higher volume production is required.

Standard In Stock Benders

- This catalog explains how standard benders form 90° bends in virtually any press working situation, from intricate progressive dies running at 250 spm, to large, fully automated panel forming machines.

- Our READY Bender® is designed specifically to replace most wipe tooling applications. This catalog explains why Benders are the better choice for you.

- Almost any length bend in practically any thickness of metal can be made using either in stock benders or by specifying your special requirements.

Special READY Benders®

- The bender is a highly efficient method of producing a wide range of different forms in metal. We make special benders, quoted by application. Use the worksheet on the back cover and email prints for a quotation.

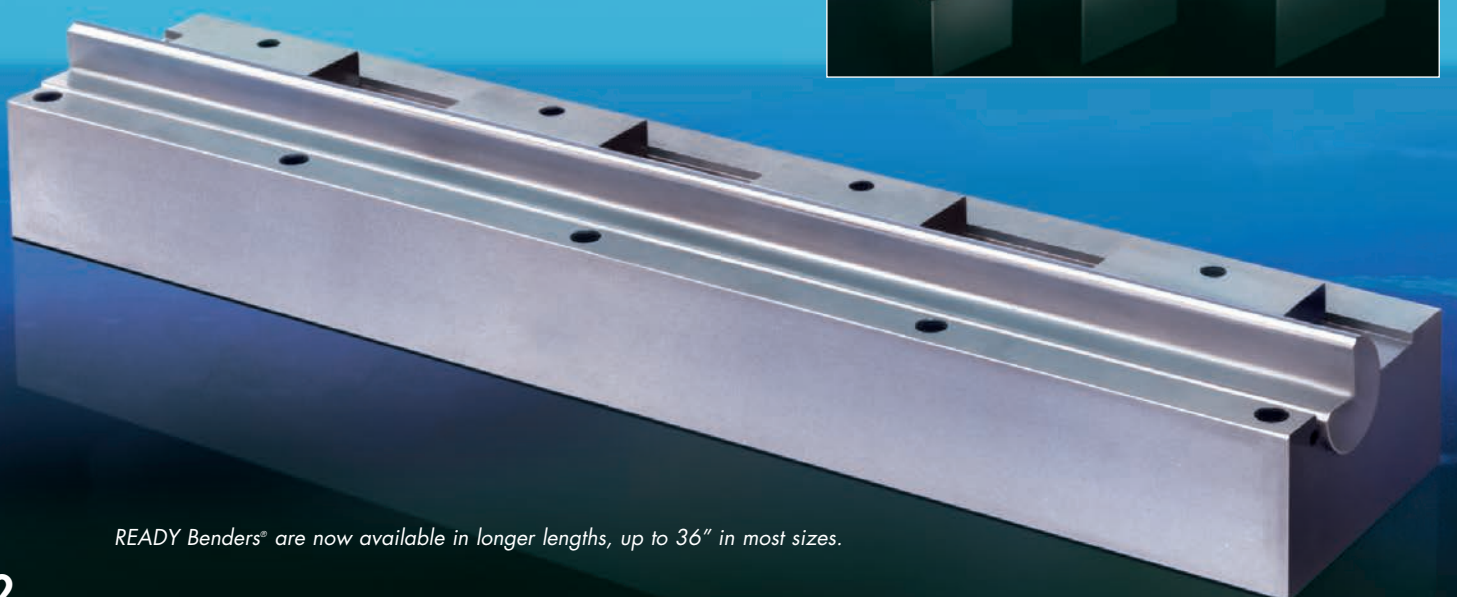
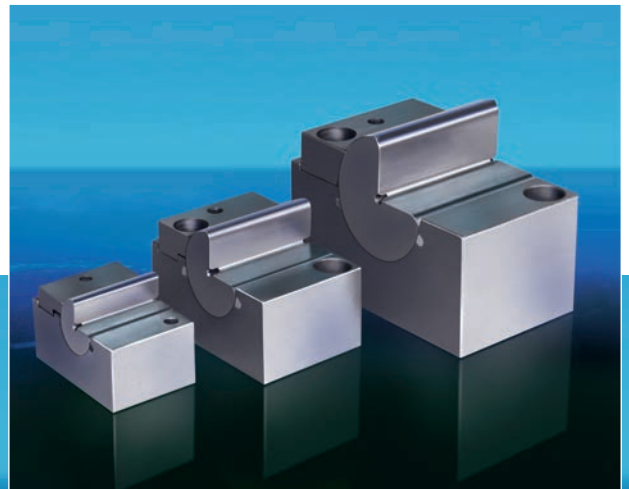

READY Benders® are now available in longer lengths, up to 36" in most sizes.

Our Test-Bending Service Takes the Guesswork Away

For a modest fee, we'll test-bend your material using our benders. This test is ideal for evaluating compatibility with pre-painted metals, checking for cutout distortion and determining the spring-back characteristics with your material.

READY Technology will test-bend your material (between .010" and .250") using our standard 87° rocker and 3° overbend. We do not bend sample parts to print.

Tell us the goal of the test bending and we will structure a test to give you answers. Send ten pieces of your material, 4" x 12" (max. length). A report and three pieces will be returned to you.

Special test-bends are available but may be expensive due to the special tooling required, averaging \$300.00, USD, each and several weeks for tooling.

We can now test bend "The Hemmer" to flatten 90° bends to 180°; see page 11.

Forming 5/8" thick high strength steel pipe hangers for naval ships. ▶

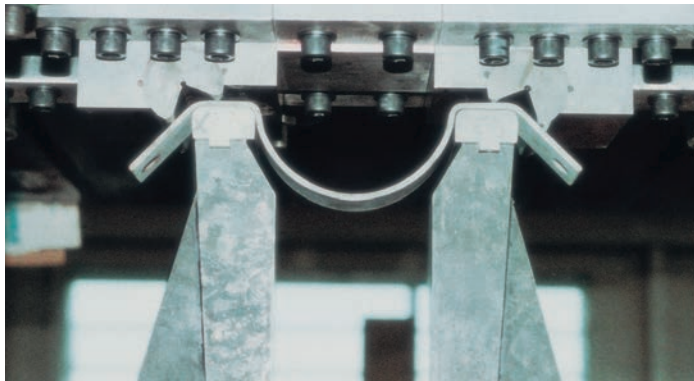

Form high strength channels with less force and increased consistency. ▶



READY Benders® are ideal for a wide range of stamping dies. ▼

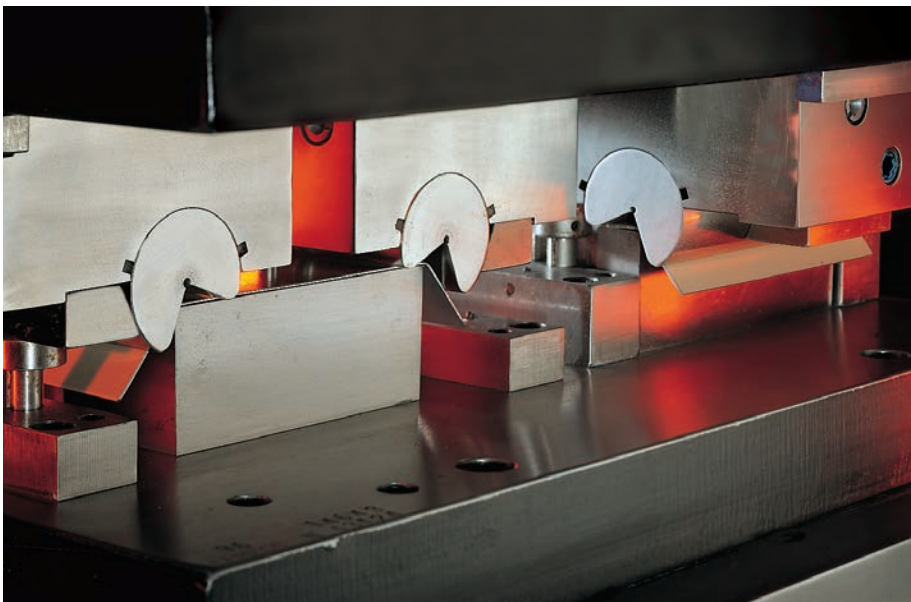

Applications, Test Bending

Bending A Short Leg



Adjustable Channel Bender

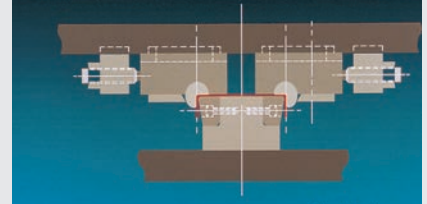

Interlaced Channel Benders

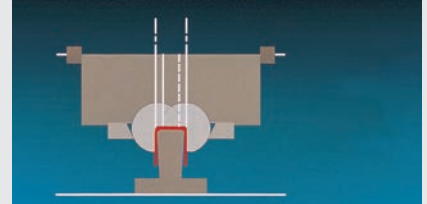

One Hit Zee Bend

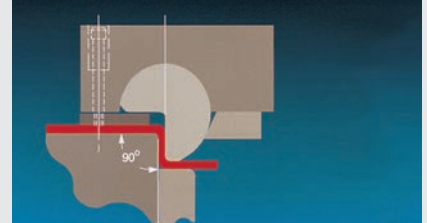

Overbend To 135° In One Stroke

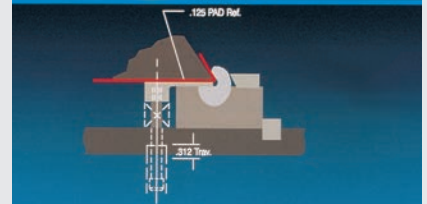

One-hit Hat Bend

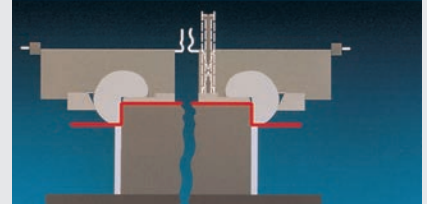

Bend Box Shapes In One Stroke

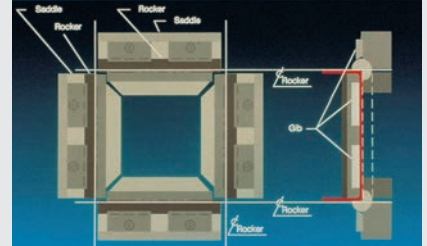

Three Reasons Toolmakers and Stampers Specify READY Benders®

1. Benders increase part quality

- Hold $\pm 1/2^\circ$ angle tolerance, no “coining” required
- Overbend up to 135° in one press stroke
- Benders are more tolerant of material thickness variations
- Hold consistent leg heights, eliminate cams and re-strikes
- Hole locations near bends are usually not distorted
- Form prepainted and decorative metal without tool marks
- Ideal for forming high strength steel and aluminum
- Form narrow channels and short leg bends

2. Benders reduce tooling costs

- Less expensive than wipe tooling - compare the costs for yourself.
- Reduce operations and eliminate die stations
- Decrease forming tonnage by 50% to 80%
- The “Hemmer”, page 11, reduces operations and costs

3. Benders work better in production and form metal consistently

- Compare the forming action:

READY Benders® - standard off the shelf

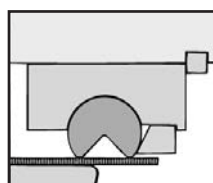

- self-contained form station

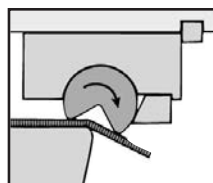

- rotary action is gentle

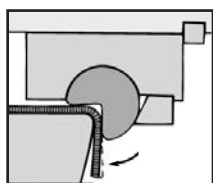

- overbend for springback
- consistent angles, leg heights, hole locations

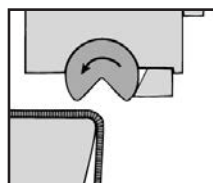

- internal spring returns rocker

Wipe Tooling - tryout and regrind

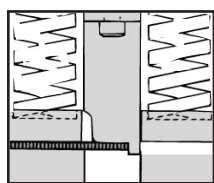

- costly extras needed

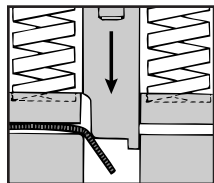

- material can hump or slide

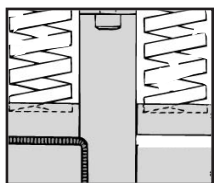

- bottom to “coin” radii
- inconsistent angles, leg heights, hole locations

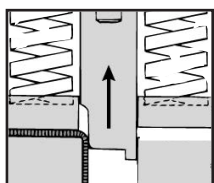

- scrapes and galls on up strokes

READY Benders® - Inch 4

READY Benders® - Inch:
In Stock Lengths 5

READY High Production
Benders - Inch 6

READY High Production
Benders - Inch: In Stock Lengths ... 7

READY High Production
Benders - Inch: Custom Lengths ... 8

Compact READY® Benders 9

Popular Bender Options

- Dart Stiffeners 10
- Tooth Benders 10
- Over Square Benders 10

The “Hemmer” 11

Pad Benders 11

Bender Location and Design Formulas

- “K” Dimension 12
- Tonnage Formula 12
- General Bend Allowance 12

Installing, Adjusting and Locating Benders 13

READY Benders® - Metric 14

READY Benders® - Metric:
In Stock Lengths 15

READY High Production
Benders - Metric 16

READY High Production
Benders - Metric: In Stock Lengths 17

READY High Production
Benders - Metric: Custom Lengths 18

READY Bender Applications
and Test Bending Service 19

READY Benders® - Inch

Benders are now less expensive than wipe tooling.

- Designed to produce up to one million parts, ideal for most stamping dies.
- In stock lengths: 12", 24" and up to 36" long.
- Segment stock lengths to reduce your tooling budget; quick delivery.
- Custom lengths available, specify.

Features:

- 1. Rockers:** fully hardened (Rc 56 to 62), S-7 tool steel.
- 2. Saddles:** machinable thru hardened steel; mounting holes left for diemaker to locate where needed. Contact Ready Engineering for suggestions.
- 3.** Saddle socket is coated for lubrication and long life. Saddle has flush mount lube fittings.
- 4.** Rockers and saddles are CNC ground for precision and interchangeability.
- 5.** Rocker angle is 87° on all standard benders. This allows for 3° of overbend to produce consistent 90° forms in mild steel. Harder steel or larger part radii may require more overbend. Rocker angles can be specified at time of order or altered by the diemaker. See page 10 about oversquare bends.

Standard READY Bender® - Inch

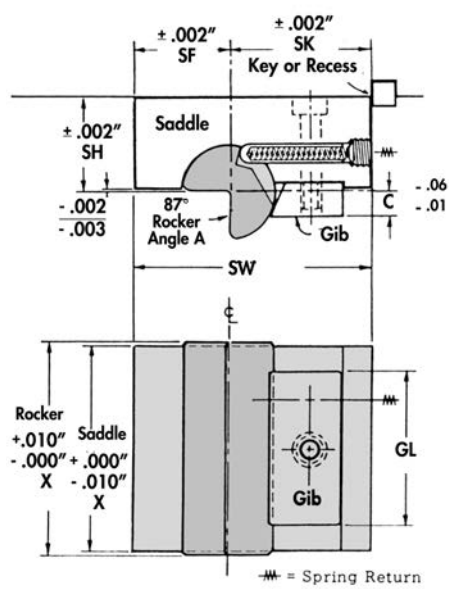

Selecting Standard Benders:

1. Find the PT you are forming in top row of chart below. Read down (vertically) for all data. Verify the PH check (specials can bend shorter PH's).
2. Note minimum and maximum lengths (X) in chart below. Custom lengths are available. Use in stock lengths whenever possible for quick delivery. Longer lengths achieved by butting units end-to-end, .010" gap between.

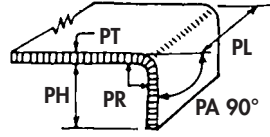

PT = part thickness
PH = part height
PR = part radius
PA = part angle
PL = part length

Standard benders form a 90° bend in mild steel. The PR should roughly equal the PT. If you have questions or need a special quotation, please email the worksheet on back cover with prints.

	Part Thickness (PT)	.010"-.042"	.043"-.075"	.076"-.120"	.121"-.164"	.165"-.209"	.210"-.250"
	Gage Thickness	25 to 19	19 to 14	14 to 11	11 to 8	8 to 5	5 to 1/4"
	Part Height Check (PH)	.250"	.390"	.580"	.775"	.970"	1.160"
	To use standard benders, PH should exceed these dimensions. Fax prints for specials.						
	In Stock Lengths, X =	12", 24"	12", 24"	12", 24", 36"	12", 24", 36"	12", 24", 36"	12", 24", 36"
	Minimum Length (X) (Gib Length - GL)	1.125"	1.500"	2.000"	2.500"	3.000"	3.500"
	Maximum Length (X)	24"	24"	36"	36"	36"	36"
	MODEL CALLOUT	HIB 62	HIB 100	HIB 150	HIB 200	HIB 250	HIB 300

	Rocker Diameter 87° Angle	.625"	1.000"	1.500"	2.000"	2.500"	3.000"
	Saddle Width (SW)	2.125"	2.875"	3.875"	4.875"	5.875"	6.875"
	Saddle to Front (SF)	.750"	1.125"	1.500"	1.875"	2.250"	2.750"
	Saddle to Key (SK)	1.375"	1.750"	2.375"	3.000"	3.625"	4.125"
	Saddle Height (SH)	.875"	1.375"	1.875"	2.375"	2.875"	3.375"
	Gib Length (GL)	1.125"	1.500"	2.000"	2.500"	3.000"	3.500"
	Rocker Dimensions						
	(B)	.212"	.339"	.508"	.678"	.848"	1.017"
	(C)	.195"	.312"	.468"	.624"	.780"	.936"
	(J)	.246"	.393"	.590"	.786"	.983"	1.179"

READY Benders® - Inch: in stock lengths 12", 24" and in some styles 36" long.

- Designed so you can segment to shorter custom lengths.
- Minimum segment size is the Gib Length (GL).
- Custom lengths available, specify.

HIB 62: 12" and 24" lengths in stock, 5/8" Diameter Rocker

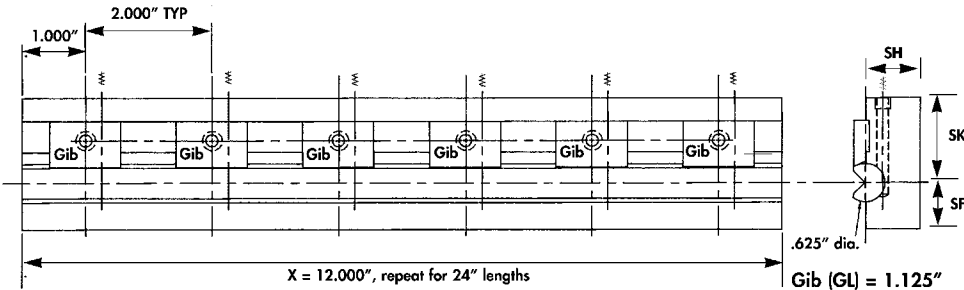

HIB 100: 12" & 24" lengths in stock, 1" Diameter Rocker

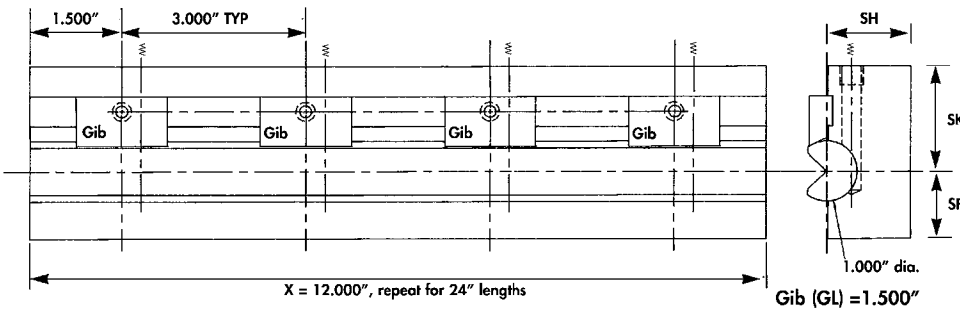

HIB 150: 12", 24" & 36" lengths in stock, 1 1/2" Diameter Rocker

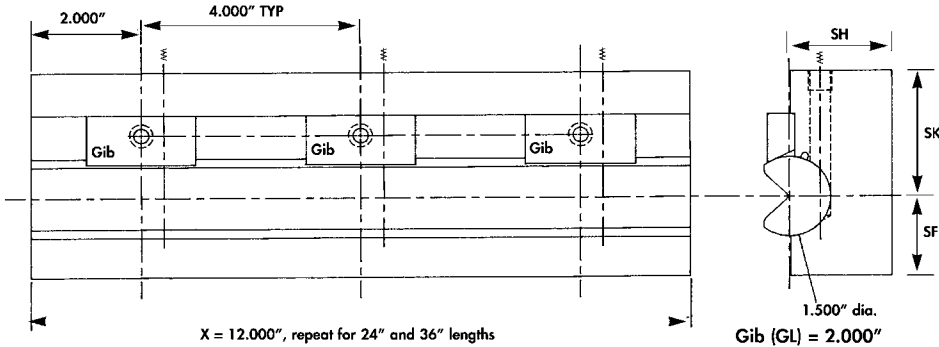

HIB 200, 250 and 300: 12", 24" & 36" lengths in stock, 2", 2 1/2" and 3" Diameter Rockers

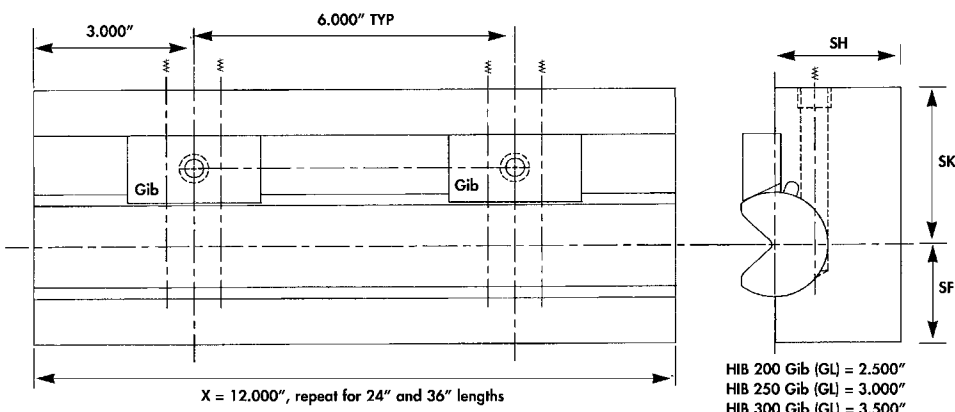

Length Segmenting:

1. 12" lengths are shown (left). 24" and 36" lengths are a repeating pattern of the 12" length.
2. Minimum segmenting size is the GL (gib length) dimension. Each segment needs a gib to retain rocker. Spring returns are marked by SR and are under gibs.

How to Segment:

1. Remove rocker by taking out set screw/lube fitting. Rotate rocker to remove the spring return plunger mechanism and rocker.
2. Rocker is fully hardened (Rc 56-62). Cut with wire machine or best way to precise length/size.
3. Saddle is machinable. Cut with wire machine or best way to precise length.
4. CAUTION: Thoroughly de-burr and clean saddle and rocker. Make sure no chips or dirt remain in saddle/rocker spring return pockets before reassembly.
5. Reassemble and check to make sure rocker returns easily when rotated.

READY Can Segment:

1. You must purchase the entire 12", 24" or 36" length and specify the segment dimensions. The remaining pieces are shipped with the tooling unless specified otherwise. No rebates on unused pieces.
2. For precision cuts, call READY for pricing - 1-800-543-4355.

Order Example:

HIB	100	X = 24"
READY Model Callout	Rocker Diameter 1"	Specify Length of Bender

SR = spring return

GL = gib length

Flush mount lube fittings at end of spring return.



READY High Production Benders - Inch

Our highest production bender - now available up to 36"

- Use when production exceeds a million parts, ideal for most stamping dies.
- In stock lengths, see page 7. Now available up to 36" long.
- For custom lengths, see page 8.

Features:

- 1. Rockers:** fully hardened (Rc 56 to 62), S-7 tool steel.
- 2. Saddles:** fully hardened, (Rc 48 to 52) A-2 tool steel. Counterbored mounting holes per patterns on pages 7 and 8. Flush mount lube fittings.
- 3.** Rockers and saddles are CNC ground for precision and interchangeability.
- 4.** Rocker angle is 87° on all standard benders. This allows for 3° of overbend to produce consistent 90° forms in mild steel. Harder steel or larger part radii may require more overbend. Rocker angles can be specified at time of order or altered by the diemaker. See page 10 about oversquare bends.

Selecting Standard Benders:

- 1.** Find the PT you are forming in top row of chart below. Read down (vertically) for all data. Verify the PH check (specials can bend shorter PH's).
- 2.** Note minimum and maximum lengths (X) in chart below. Custom lengths are available. Use in stock lengths whenever possible for quick delivery. Longer lengths achieved by butting units end-to-end, .010" gap between.

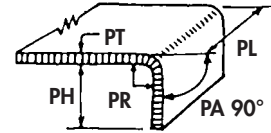

PT = part thickness
 PH = part height
 PR = part radius
 PA = part angle
 PL = part length

Standard benders form a 90° bend in mild steel. The PR should roughly equal the PT. If you have questions or need a special quotation, please email the worksheet on back cover with prints.

Part Thickness (PT)	.010"-.042"	.043"-075"	.076"-.120"	.121"-.164"	.165"-.209"	.210"-.250"
Gage Thickness	25 to 19	19 to 14	14 to 11	11 to 8	8 to 5	5 to 1/4"
Part Height Check (PH)	.250"	.390"	.580"	.775"	.970"	1.160"
To use standard benders, PH should exceed these dimensions. Fax prints for specials.						
In Stock Lengths, X = (see page 7)	1.125" 3.500" 6.000"	1.500" 4.000" 6.000" 9.000"	2.000" 5.000" 8.000"	2.500" 7.000"	3.000" 7.000"	3.500" 6.000"
Minimum Length (X) (Gib Length - GL)	1.125"	1.500"	2.000"	2.500"	3.000"	3.500"
Maximum Length X	24"	24"	36"	36"	36"	36"
MODEL CALLOUT	REC 62	REC 100	REC 150	REC 200	REC 250	REC 300

Standard READY High Production Bender

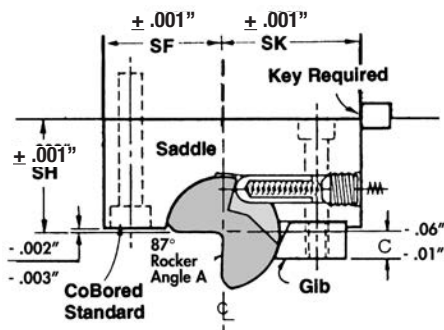

- Tapped mounting holes available as specials.
- For metric mounting holes, see READY High Production Benders, pages 16 to 18.

Rocker Diameter (87° Angle)	.625"	1.000"	1.500"	2.000"	2.500"	3.000"
Saddle Width (SW)	2.125"	2.875"	3.875"	4.875"	5.875"	6.875"
Saddle to Front (SF)	.750"	1.125"	1.500"	1.875"	2.250"	2.750"
Saddle to Key (SK)	1.375"	1.750"	2.375"	3.000"	3.625"	4.125"
Saddle Height (SH)	.875"	1.375"	1.875"	2.375"	2.875"	3.375"
Gib Length (GL)	1.125"	1.500"	2.000"	2.500"	3.000"	3.500"
Rocker Dimensions						
(B)	.212"	.339"	.508"	.678"	.848"	1.017"
(C)	.195"	.312"	.468"	.624"	.780"	.936"
(J)	.246"	.393"	.590"	.786"	.983"	1.179"

READY High Production Benders - Inch: in stock lengths

READY High Production Benders **INCH**

- Our highest production bender.
- Custom lengths up to 24" or 36" long available, see page 8.

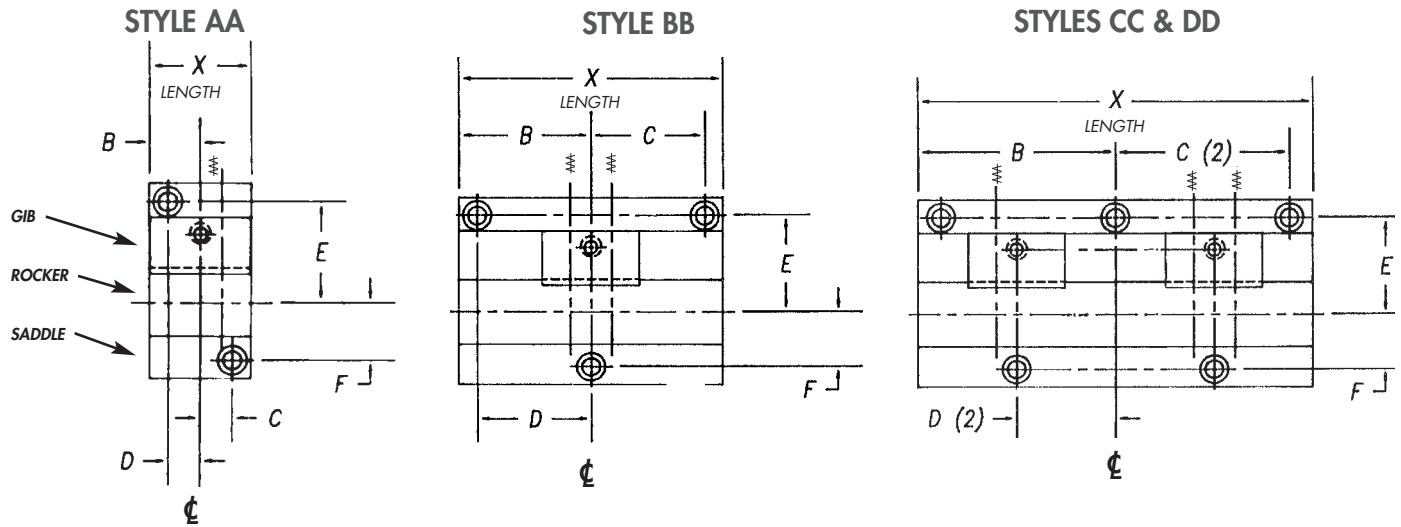

Mounting Hole Locations

Model Callout	Length Style	X Length	B	C	D	E	F	SHCS size
REC 62	AA	1.125"	.562"	.354"	.354"	1.181"	.551"	#10
	CC	3.500"	1.750"	1.514"	.875"	1.181"	.551"	#10
	DD	6.000"	3.000"	2.764"	1.500"	1.181"	.551"	#10
REC 100	AA	1.500"	.750"	.472"	.472"	1.476"	.846"	1/4"
	BB	4.000"	2.000"	1.724"	1.724"	1.476"	.846"	1/4"
	CC	6.000"	3.000"	2.645"	1.500"	1.476"	.846"	1/4"
	DD	9.000"	4.500"	4.146"	2.250"	1.476"	.846"	1/4"
REC 150	AA	2.000"	1.000"	.669"	.669"	1.969"	1.181"	5/16"
	BB	5.000"	2.500"	2.028"	2.028"	1.969"	1.181"	5/16"
	CC	8.000"	4.000"	3.409"	2.000"	1.969"	1.181"	5/16"
REC 200	AA	2.500"	1.250"	.846"	.846"	2.598"	1.476"	3/8"
	BB	7.000"	3.500"	2.909"	2.909"	2.598"	1.476"	3/8"
REC 250	AA	3.000"	1.500"	.984"	.984"	3.110"	1.732"	1/2"
	BB	7.000"	3.500"	2.791"	2.791"	3.110"	1.732"	1/2"
REC 300	AA	3.500"	1.750"	1.280"	1.280"	3.642"	2.244"	1/2"
	BB	6.000"	3.000"	2.291"	2.291"	3.642"	2.244"	1/2"

Tolerances Held

X = saddle length
+.000"/-.010"

X = rocker length
+.010"/-.000"

Screw locations
held ± .005"

Order Example:

REC	100	X = DD
READY Model Callout	Rocker Diameter 1"	Specify Length of Bender

READY High Production Benders - Inch: Custom Lengths

- READY'S CNC grinding technology delivers custom lengths up to 36" long at attractive prices.
- Longer lengths achieved by butting two or more units end-to-end, .010" gap.

- Now available up to 36" long.
- Specify your desired length (X) and READY will deliver.

REC 62, 100 and 150 Repeating Hole Patterns
(for 5/8", 1", and 1 1/2" Diameter Rockers)

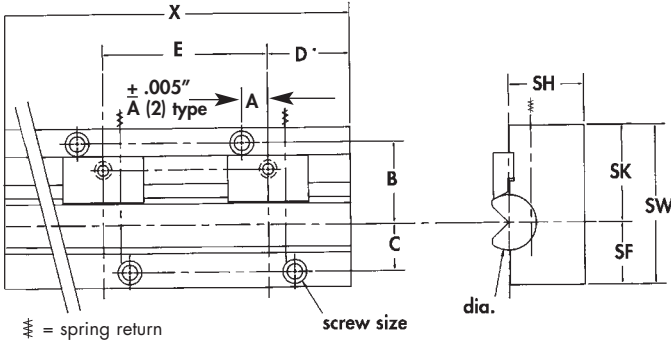

REC 200, 250 and 300 Repeating Hole Patterns
(for 2", 2 1/2", and 3" Diameter Rockers)

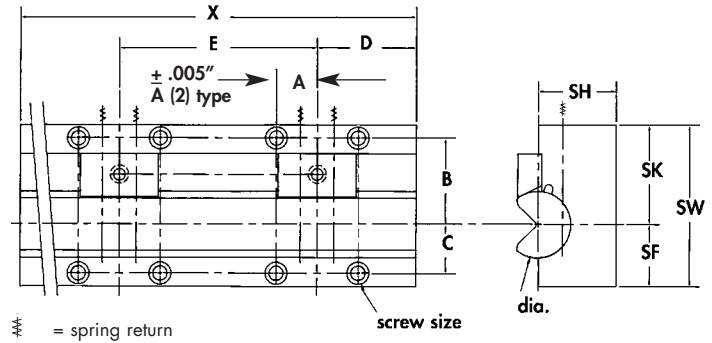

Minimum/Maximum Lengths:

1. Charts and drawings showing hole locations start at nominal lengths. Custom lengths start very short, at catalog Gib Length (GL) dimensions.
2. Mounting hole patterns for shorter, custom lengths are available upon request by application.

- REC 62** Minimum 1.125" (GL) Maximum 24"
- REC 100** Minimum 1.500" (GL) Maximum 24"
- REC 150** Minimum 2.000" (GL) Maximum 36"
- REC 200** Minimum 2.500" (GL) Maximum 36"
- REC 250** Minimum 3.000" (GL) Maximum 36"
- REC 300** Minimum 3.500" (GL) Maximum 36"

3. Standard in stock lengths of READY High Production Benders are cataloged on page 7. These ship fast and cost less. The READY Bender® - Inch, pages 4 and 5, is available in custom lengths and can further reduce your tooling budget.

NOTE:

- Counterbored holes standard, tapped available as specials.
- READY High Production Bender - metric, pages 16 to 18, is the same product only with metric holes.

Model and Rocker Diameter	"X" Length	A	B	C	D	E	SHCS size
REC 62 5/8" dia.	lengths 6 - 12"	.354"	1.181"	.551"	"X" ÷ 8	"X" ÷ 4	#10
REC 100 1" dia.		.472"	1.476"	.846"	"X" ÷ 8	"X" ÷ 4	1/4
REC 150 1 1/2" dia.		.669"	1.969"	1.181"	"X" ÷ 6	"X" ÷ 3	5/16
REC 62 5/8" dia.	lengths 12.5 - 24"	.354"	1.181"	.551"	"X" ÷ 12	"X" ÷ 6	#10
REC 100 1" dia.		.472"	1.476"	.846"	"X" ÷ 12	"X" ÷ 6	1/4
REC 150 1 1/2" dia.		.669"	1.969"	1.181"	"X" ÷ 10	"X" ÷ 5	5/16
REC 62 5/8" dia.	lengths 24.5 - 36"	.354"	1.181"	.551"	"X" ÷ 16	"X" ÷ 8	#10
REC 100 1" dia.		.472"	1.476"	.846"	"X" ÷ 16	"X" ÷ 8	1/4
REC 150 1 1/2" dia.		.669"	1.969"	1.181"	"X" ÷ 14	"X" ÷ 7	5/16
REC 200 2" dia.	lengths 8 - 12"	1.240"	2.598"	1.476"			3/8
REC 250 2 1/2" dia.		1.378"	3.110"	1.732"	"X" ÷ 4	"X" ÷ 2	1/2
REC 300 3" dia.		1.575"	3.642"	2.244"			1/2
REC 200 2" dia.	lengths 12.5 - 24"	1.240"	2.598"	1.476"			3/8
REC 250 2 1/2" dia.		1.378"	3.110"	1.732"	"X" ÷ 6	"X" ÷ 3	1/2
REC 300 3" dia.		1.575"	3.642"	2.244"			1/2
REC 200 2" dia.	lengths 24.5 - 36"	1.240"	2.598"	1.476"			3/8
REC 250 2 1/2" dia.		1.378"	3.110"	1.732"	"X" ÷ 10	"X" ÷ 5	1/2
REC 300 3" dia.		1.575"	3.642"	2.244"			1/2

Compact READY Benders®

• Designed to fit "tight" die spaces, small footprint.

- Recommended for high production applications.
- Hardened tool steel, all surfaces precision ground. Rockers Rc 56-62. Saddles Rc 48-52. Chase or Yoke mounting by die maker.
- Standards in stock for fast delivery. Special compact benders can be made to your height and length requirements upon request.



Selection and Ordering:

1. Locate the material thickness you are forming on the top row. Read down the column for your data.
2. Longer lengths are achieved by butting units end-to-end.
3. We make special compact benders. Email the worksheet on the back cover with prints.

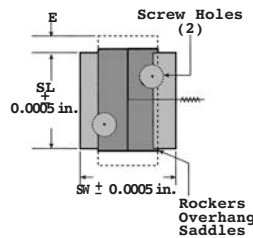
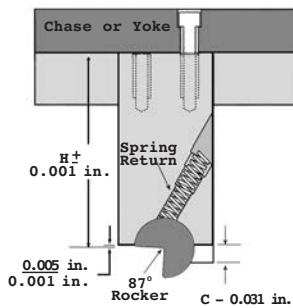

Regular Benders

Note: extended rockers (E) are special

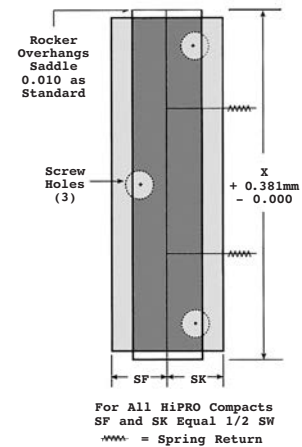

For All HiPRO Compacts SF and SK Equal 1/2 SW
 ~~~ = Spring Return  
**Long Benders**  
 Ends of saddles are not ground

| PART MATERIAL              |         | PART MATERIAL THICKNESS RANGES (inches) |                 |                 |                 |
|----------------------------|---------|-----------------------------------------|-----------------|-----------------|-----------------|
| Mild Steel                 |         | .010" - .042"                           | .043" - .075"   | .076" - .120"   | .121" - .165"   |
| REGULAR BENDERS            |         | STANDARD                                |                 |                 |                 |
| Catalog Callout (stocked)  |         | HCBT 62                                 | HCBT 100        | HCBT 150        | HCBT 200        |
|                            |         | Bender Dimensions                       |                 |                 |                 |
| Rocker Diameter            | D       | .625                                    | 1.000           | 1.500           | 2.000           |
| Regular Benders            | SW x SL | 1.000" x 1.000"                         | 1.500" x 1.500" | 2.000" x 2.000" | 3.000" x 3.000" |
| Height                     | H       | 2.000"                                  | 2.000"          | 2.750"          | 3.000"          |
| Rocker Extension (special) | E       | 1/4"                                    | 1/4"            | 3/8"            | 1/2"            |
| LONG BENDERS               |         | SPECIAL ORDER                           |                 |                 |                 |
| Catalog Callout (special)  |         | HCLT 62                                 | HCLT 100        | HCLT 150        | HCLT 200        |
| Long Benders, width        | SW      | 1.000"                                  | 1.500"          | 2.000"          | 3.000"          |
| Length (specify)           | X       | 1.500" - 6.000"                         | 2.000" - 8.000" | 2.500" - 8.000" | 4.000" - 8.000" |
| Height (specify)           | H       | 2.000" - 3.000"                         | 2.000" - 3.000" | 2.750" - 3.750" | 3.000" - 4.000" |
| Rocker Dimensions          |         | Designer Dimensions (87° Rocker)        |                 |                 |                 |
|                            | B       | .212"                                   | .339"           | .508"           | .678"           |
|                            | C       | .195"                                   | .312"           | .468"           | .624"           |
|                            | J       | .246"                                   | .393"           | .590"           | .786"           |
| SHCS screws                |         | 1/4 - 20                                | 5/16 - 18       | 5/16 - 18       | 1/2 - 13        |

## Take Advantage of the Latest Bender Technology

READY encourages upgrading to the improved designs detailed in this catalog for best performance, delivery, and lowest tooling costs. We now offer compact in longer lengths.

We make specials too ... use the worksheet on back cover and email prints.

## Popular Bender Options

*"Wipe Tooling" darts are high maintenance - Benders make it simple.*

Eliminate:

- galling and maintenance
- unattractive parts
- secondary operations

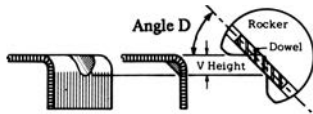

**V Height** – The only dimension darts can hold because material thickness varies.

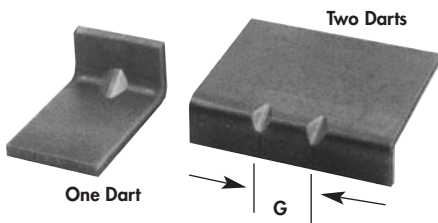

### 1. Dart Stiffeners ... Benders Make it Easy

Standard darts are shown below or you can specify your own angle and dowel size. Darts are rolled into the part during bending, reducing springback and stiffening the part. Darts are produced using dowels through the rocker and require relief grooves in the anvil. The side angles of the darts are a function of the angle and size of the dowel.

| Vee Height | Rocker Diameters |      |       |      |       |      |
|------------|------------------|------|-------|------|-------|------|
|            | 5/8              | 1    | 1-1/2 | 2    | 2-1/2 | 3    |
| .100"      | V1               | V1   | --    | --   | --    | --   |
| .200"      | V2*              | V2   | V2    | --   | --    | --   |
| .350"      | --               | V3*  | V3    | V3   | --    | --   |
| .500"      | --               | --   | V5*   | V5*  | V5    | V5   |
| Dowel      | .093             | .156 | .250  | .312 | .375  | .500 |

\*Dowel may be upsized to avoid a gap between the rocker and the dowel.

Darts are available as specifiable extras on all READY Benders®. Darts are central on a 45° angle unless detailed.

**Benders gently roll stiffening "darts" into a wide range of formed parts.**

#### How to Specify

Add your selection of Dart Spec. No. after Catalog Number:

|          |                |               |                            |
|----------|----------------|---------------|----------------------------|
| <u>2</u> | <u>REC 150</u> | <u>X = 2"</u> | <u>2 V3, Darts, G = 1"</u> |
| Qty      | Cat. No.       | Length        | Dart Callout               |

### Tooth Benders

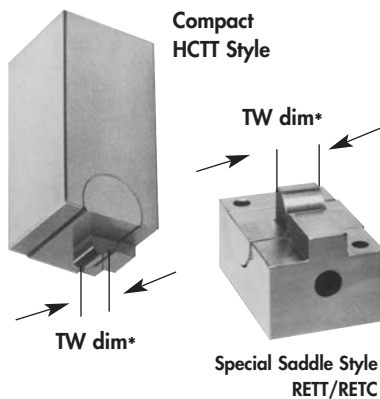

### 2. Tooth Benders ... Eliminate Part/Die Interferences

Tooth benders use special rockers to eliminate die/part interferences. Often the saddle needs to be made special without gibs in one piece. Send prints for a quotation.

#### How to Specify

Add TW dimension after Catalog Number:

|     |           |          |
|-----|-----------|----------|
| 2   | HCTT 62   | TW .400" |
| 1   | RETT 100  | TW .500" |
| 2   | RETCT 100 | TW .500" |
| Qty | Cat. No.  | TW dim.  |

| Rocker Diameter D | Min. TW Dimensions |                                  |
|-------------------|--------------------|----------------------------------|
|                   | Compact Style HCTT | Special Saddle Style, RETT/RETCT |
| .625              | .312               | .312                             |
| 1.000             | .500               | .438                             |
| 1.500             | .625               | .500                             |
| 2.000             | .750               | .625                             |
| 2.500             | ---                | .688                             |
| 3.000             | ---                | ---                              |

\*TW central unless detailed.

Please note: The saddle is special (gib built-in) to accept a narrow rocker tooth width. Tooth benders are available on all types of READY Benders® as specials.

### Over Square Bends

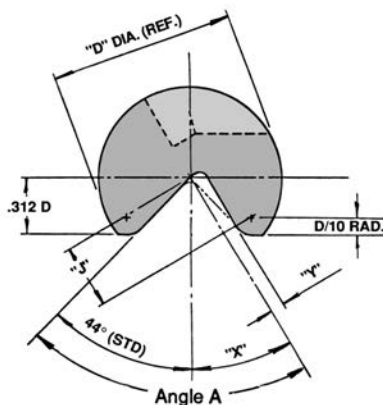

### 3. Over Square Bends ... up to 135° in one press stroke

The READY Bender's® ability to bend 45° beyond ninety (135° PA) is one of its greatest features. Customers buy standards and do this simple alteration themselves, adding a degree or two of overbend to the rocker. This easy alteration is done by grinding the bending jaw of the rocker, while not disturbing the working radius of the bending lobe (grind past centerline).

**For assistance, call READY Technology and we will give you the necessary dimensions to make this alteration.**

**Note:** Severe overbend (over 109° PA) with a small radius (less than PT) can create a situation where the rocker may catch on the anvil.

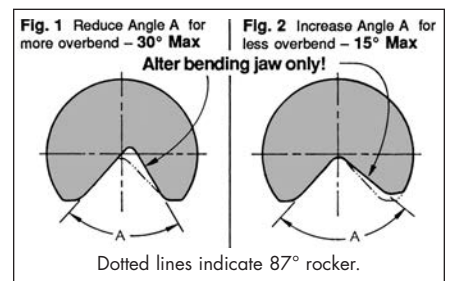

READY will check your application and advise if a pad or special rocker design is needed.

It's easy to alter rockers for more or less overbend. Example shows standard 87° rocker. Check to make sure the Anvil has more relief angle than the rocker angle A. Rockers are easy to alter.

# The "Hemmer"

- Eliminate Die Stations and Operations;
- Use in Progressive Dies, Automated Machines

This patented tool can form a slightly open bend completely flat in one vertical press stroke. Use it to form UP or DOWN in high production stamping dies and automated machines. Eliminate the cam action "pre-hem" operation and do hems in two stations instead of three.

We use full hard D-2 rockers and special READY High Production style saddles. This is a special bender, yet attractively priced.

All hem applications should be quoted by READY. Fax prints and the worksheet on the back cover. We usually suggest a test-bend using your material to accurately predict results and select the right hemmer design. We charge a modest fee for this service, based upon the application.

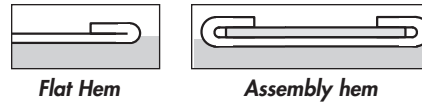

## Important Hemmer Functions

1. Diameter may be chosen more by leg height than material thickness.
2. Hemmer dimensions are the same as REC models, except rocker is in the center of the saddle.
3. Testing is highly recommended on all hem applications to help determine proper positioning.
4. Pressure pad needed to avoid sliding as hemmer contacts and flattens.
5. Maximum hemmer length is 12". For longer lengths, butt end-to-end with .010" gap between saddles.

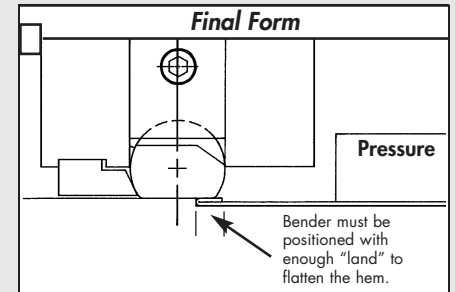
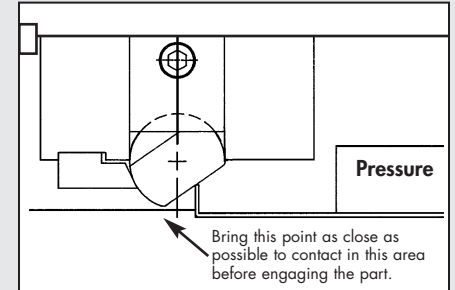

# Pad Benders

Not Just for Elimination of Tool Marks

Hardened Steel Pads can help in many bender applications. By activating the bender on top of a hard pad, you isolate the rocker from the part on the critical holddown surface. NO CONTACT = NO MARK.

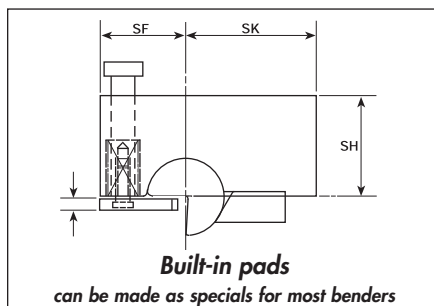
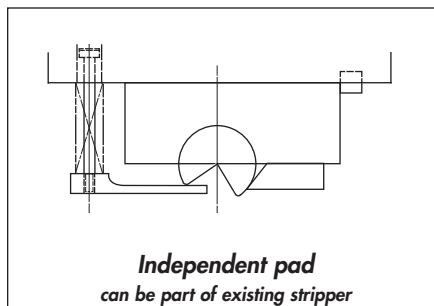

## Important Pad Functions

1. Hardened Pads can be designed to match a part's "irregular" shape on one side yet be flat and parallel on the surface that the bender contacts.
2. Eliminates rocker contact and impact on part holddown surface.
3. To protect a part cutout or hole from distortion due to its proximity to the bend line.
4. To eliminate humping of the material when the application dictates upsizing the rocker diameter. The pad provides holddown pressure close to the bend radius.
5. To match a standard rocker diameter to the Zee bend or offset vertical height. Allows use of standard rockers versus making specials.

## When Using Pads, READY Technology Recommends:

1. Locate the pad and its shoulder screws/ spools as close as possible to the tangency point of the radius. This location and bushings or guides will prevent the pad from tipping.
2. Springs to lift the pad should work separately from the spring return of the bender.
3. Additional part holddown may be required in some applications (pilots, die springs or nitrogen cylinders).

# Bending Without Tool Marks

READY Benders® normally leave a slight burnish or shine mark on both part surfaces. This is a big improvement over wipe tool scrapes and gouges.

Elimination of tool marks is not just for prepainted metal - one of our big success areas. Use of pads (bottom, left) and highly polished steel rockers are very successful on prepaint and other decorative surfaces.

Depending on acceptable tool mark criteria, we have the solution to most situations. Test-bending (page 19) is the safe approach. For a modest fee, we will form your material using our benders and send you a report with your sample for evaluation.

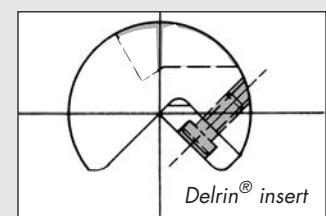

Solid Delrin® Rockers or Delrin® Inserted Rockers are used without pads on low to medium production applications.

Delrin® is a registered trademark of E.I. DuPont.

# Bender Location and Design Formulas:

## Bender Location ... "K" Dim.

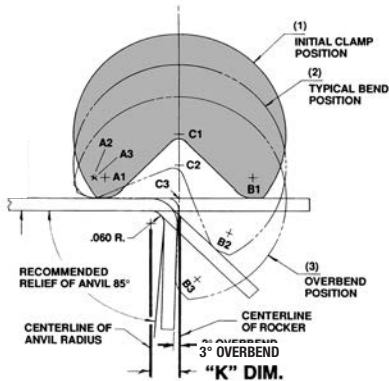

The formula for the "K" dimension of a 87° standard rocker is:

Formula for 'A' = 87°, rocker  

$$K = \frac{PT + PR}{\tan(A/2)}$$

## 1. Bender location ... CAD compatible "K" Dimension

The "K" Dimension is the distance between the centerline of the anvil radius and the centerline of a fully closed bending lobe. Its purpose is to aid the designer in dimensioning the key slots needed to locate the READY Bender® easily.

The "K" Dimension changes as an overbend is added to or subtracted from the bending lobe. Though the centerline of the rocker is constant, it will move closer to or further from the anvil radius.

When the toolmaker actually sets the READY Bender®, he is in fact setting to the "K" Dimension. Correct setting of the bender will provide for longer tool life and better parts.

These formulas are only valid for square 90° bend angles. For overbends up to 135° or underbends down to 60°, please consult READY. Due to the trigonometric variations, the formulas are completely changed and can not be generalized.

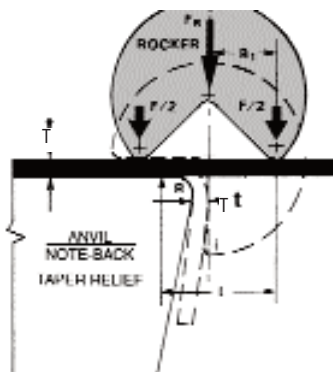
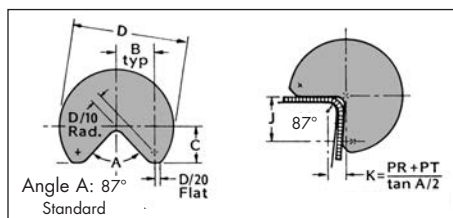

(Clamp position shown solid, overbend position dotted)

## 2. Tonnage Formula for READY Benders®

READY Benders® require 50-80% less tonnage than wipe bending tools. The clamping lobe provides part holddown from first contact, the bending lobe has greater bending leverage. The ability to overbend up to 135° eliminates the need for coining and bottoming.

- F = force required
- S = nominal ultimate tensile strength
- W = width of bend
- T = stock thickness
- L = span (as a beam)  $L = B + R + T$
- B = designer dimension of 1" dia. rocker
- R = anvil radius

Example:

$$F = 2.25 \times \frac{SWT^2}{L}; L = B_1 + T + R = 0.343 + 0.060 + 0.060 = 0.463$$

(1" DIAMETER ROCKER)

$$F = \frac{2.25 \times 50,000 \times 1" \times 0.060^2}{0.463} = 875 \text{ lb.} = 0.44 \text{ ton}$$

**Benders require 50-80% less tonnage than wipe tools.**

## 3. General Bend Allowance Formula

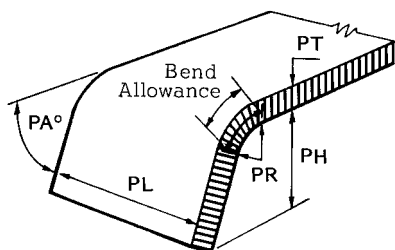

Bend Allowance

READY Benders® overbend to allow for springback instead of coining the part material to "set" the bend. As a result, benders leave more material within the bend radius so the bend allowance is greater than wipe bending.

**Caution.** As we all know, bend allowance may change with different materials and even within different coils of the same material. The only way to be sure of the bend allowance is to test the material and measure the BA. (See Test Bending Service, page 19).

The general formula is:

$$\text{Bend Allowance (BA)} = .01745 \times PA \times [PR + (PT \times .43)]$$

# How To Install READY Benders®

1. Release the return spring(s) and plunger(s) by releasing the lube fitting or set screw so the rocker can rotate freely. Do not remove the gib from the saddle.
2. Using two pieces of the part material, place one piece on the holddown side of the anvil near to but not into the anvil radius (see drawing right). Put the bender into approximate position.
3. Keeping the second piece of material flush to the bending lobe of the rocker, like a feeler gage (moving up and down minorly), set the opening between the tangency of the anvil radius and the bending jaw of the rocker. The anvil should be ground with 2° to 3° more back taper relief than the rocker's angle "A" being used.
4. Locate the bender with a key for proper location and resistance to side load.

5. Tighten the fastening screws. Lubricate the bender with light oil. Make sure no debris has lodged in spring return area, especially after machining mounting holes.
6. **Bender Adjustment.** You can vary overbend by minor shut height adjustments. Progressive dies are usually best adjusted by moving the bender slightly in (closer to anvil) for more overbend, or out (away from anvil) for less overbend. The standard 87° rocker only has 3° overbend. Anvil inserts can be shimmed or reground to avoid moving the bender.
7. For more details to properly locate READY Benders®, see page 12.

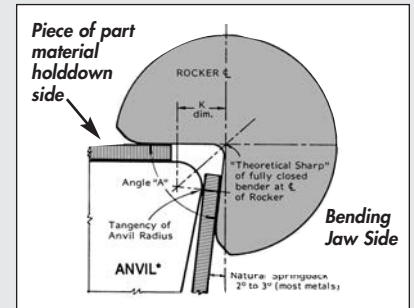
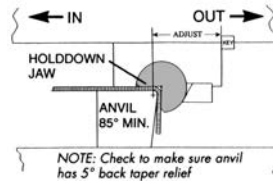

\*NOTE: The back taper relief ground on the anvil is to allow for the overbend required without pinching the material at full closure. (85° minimum anvil angle suggested for all 90° bends). Always grind 2° to 3° more back taper on anvil than the rocker's angle "A" being used.

**Critical - Once the holddown jaw is parallel to the material, ALL adjustments must be in or out. The rocker can be reground to add overbend...**

## Troubleshooting Guide

| Problems                        | Solutions                                                                                                                                                                                                                                                                                                                                        |
|---------------------------------|--------------------------------------------------------------------------------------------------------------------------------------------------------------------------------------------------------------------------------------------------------------------------------------------------------------------------------------------------|
| <b>1. UNDERBENT</b><br>         | <p>A. Bender is set "too open"..... Reset bender per instructions.</p> <p>B. Material is too thick..... Use the next larger bender.</p> <p>C. Part radius is too large..... Use the next larger bender, or reduce the part radius.</p> <p>D. Material is "springy"..... Decrease angle A per Fig. 1 below and reset bender per instructions.</p> |
| <b>2. OVERBENT</b><br>          | <p>A. The bender is set too tight.... Reset bender per instructions.</p> <p>B. Part material is too soft..... Increase angle A per Fig. 2 below and reset bender per instructions.</p> <p>C. Part radius is too small..... Increase angle A per Fig. 2 below. Another option is to match rocker and anvil to 90°. <b>No coining.</b></p>         |
| <b>3. HOOK</b><br>              | <p>A. Material is being "trapped" at the tangency (pinch point)... Reset bender per instructions. Check anvil radius, it may be too small. Call READY Technology.</p> <p>B. Rocker is too large for the material thickness..... Refer to catalog page for correct rocker size and set per instructions.</p>                                      |
| <b>4. EXCESSIVE MARKING</b><br> | <p>A. Bender is set too tight..... Reset bender per instructions.</p> <p>B. Material is too thick or too strong for rocker diameter..... Refer to catalog page for correct rocker size and set per instructions.</p> <p>C. Not enough relief on the anvil. Increase relief angle to 2° - 3° less than angle A of rocker</p>                      |

### 5. SADDLE IMPRINTING ONTO THE PART

**BENDER IS SET MUCH TOO DEEP!**  
**STOP!** Once the holddown jaw is parallel to the material, ALL adjustments must be in or out. The rocker can be reground to add overbend.  
**See bender adjustment top of page.**

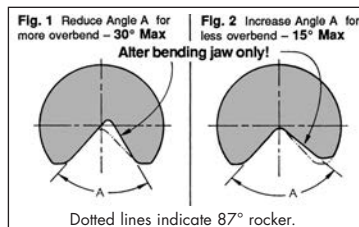

## READY Can Help You

A copy of bender installation instructions are packaged with every bender shipped. We can assist you if you have technical questions or concerns.

**Please note, most problems with benders are easy to fix!**

- The #1 biggest problem is not enough back taper relief on the anvil or insert that we form material around. Do not assume - please check 85° minimum for all 90° bends (2° to 3° more relief than the rocker's angle A which is 87° standard).
- Too often the bender is improperly located either too close or too far away from the anvil. Check the "K" dimension as per the setting instructions.

## Ordering Replacements

*keep a back-up unit in the crib!*

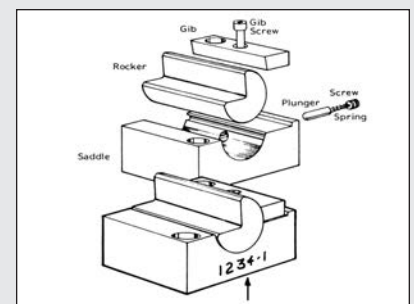

**Bender ID No. for replacement and back-up. Reference this when ordering replacements. To order service kit, state model number or bender ID number followed by "K".**



# READY Benders® - Metric

*Metric Benders are now less expensive than wipe tooling.*

- Designed to produce up to one million parts, ideal for most stamping dies.
- In stock lengths: 304.8, 609.6 and up to 914.4 mm long.
- Segment stock lengths to further reduce your tooling budget; quick delivery.
- Custom lengths available, specify.

**Features:**

- 1. Rockers:** fully hardened (Rc 56 - Rc 62), S-7 tool steel. Rockers and gibs are held to inch dimensions.
- 2. Saddles:** machinable thru hardened steel; mounting holes left for diemaker to locate where needed. Contact Ready Engineering for suggestions.
- 3. Saddle socket** is coated for lubrication and long life. Saddle has flush mount lube fittings.
- 4. Rockers and saddles** are CNC ground for precision and interchangeability.
- 5. Rocker angle** is 87° on all standard benders. This allows for 3° of overbend to produce consistent 90° forms in mild steel. Harder steel or larger part radii may require more overbend. Rocker angles can be specified at time of order or altered by the diemaker. See page 10 about oversquare bends.

**Selecting Standard Benders:**

1. Find the PT you are forming in top row of chart below. Read down (vertically) for all data. Verify the PH check (specials can bend shorter PH's).
2. Note minimum and maximum lengths (X) in chart below. Custom lengths are available. Use in stock lengths whenever possible for quick delivery. Longer lengths achieved by butting units end-to-end, .254 mm gap between.

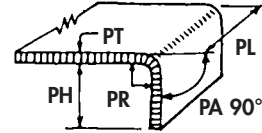

PT = part thickness  
 PH = part height  
 PR = part radius  
 PA = part angle  
 PL = part length

*Standard benders form a 90° bend in mild steel. The PR should roughly equal the PT. If you have questions or need a special quotation, please email the worksheet on back cover with prints.*

All dimensions are in millimeters.

| Part Material Thickness (PT)                                                         | 0.25-1         | 1-1.9          | 1.9-3                   | 3-4.1                   | 4.1-5.3                 | 5.3-6.4                 |
|--------------------------------------------------------------------------------------|----------------|----------------|-------------------------|-------------------------|-------------------------|-------------------------|
| Part Height Check (PH)                                                               | 6.35           | 9.9            | 14.8                    | 19.7                    | 24.6                    | 29.5                    |
| To use standard benders, PH should exceed these dimensions. Fax prints for specials. |                |                |                         |                         |                         |                         |
| In Stock Lengths, X =                                                                | 304.8<br>609.6 | 304.8<br>609.6 | 304.8<br>609.6<br>914.4 | 304.8<br>609.6<br>914.4 | 304.8<br>609.6<br>914.4 | 304.8<br>609.6<br>914.4 |
| Minimum Length (X) (Gib Length - GL)                                                 | 28.6           | 38.1           | 50.8                    | 63.5                    | 76.2                    | 88.9                    |
| Maximum Length (X)                                                                   | 609.6          | 609.6          | 914.4                   | 914.4                   | 914.4                   | 914.4                   |
| MODEL CALLOUT                                                                        | RBM 62         | RBM 100        | RBM 150                 | RBM 200                 | RBM 250                 | RBM 300                 |

**Standard READY Bender® - Metric**

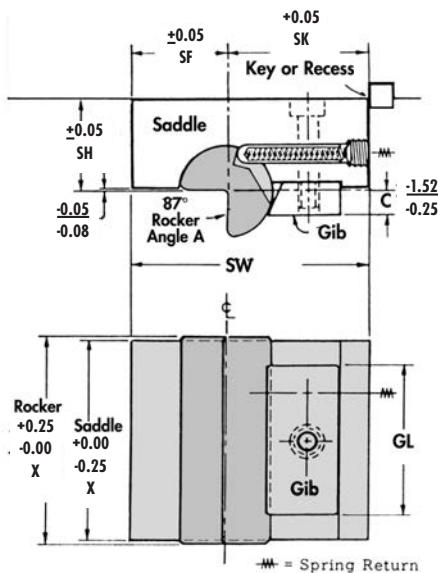

|                             |       |       |       |        |        |        |
|-----------------------------|-------|-------|-------|--------|--------|--------|
| Rocker Diameter (87° Angle) | 15.88 | 25.4  | 38.1  | 50.8   | 63.5   | 76.2   |
| Saddle Width (SW)           | 53.98 | 73.03 | 98.42 | 123.83 | 149.23 | 174.63 |
| Saddle to Front (SF)        | 19.05 | 28.58 | 38.10 | 47.63  | 57.15  | 69.85  |
| Saddle to Key (SK)          | 34.93 | 44.45 | 60.33 | 76.20  | 92.08  | 104.78 |
| Saddle Height (SH)          | 22.23 | 34.93 | 47.63 | 60.33  | 73.03  | 85.73  |
| Gib Length (GL)             | 28.6  | 38.1  | 50.8  | 63.5   | 76.2   | 88.9   |
| Rocker Dimensions           |       |       |       |        |        |        |
| (B)                         | 5.39  | 8.61  | 12.90 | 17.22  | 21.54  | 25.83  |
| (C)                         | 4.95  | 7.93  | 11.89 | 15.85  | 19.81  | 23.77  |
| (J)                         | 6.24  | 9.98  | 14.97 | 19.96  | 24.95  | 29.94  |

# READY Benders® - Metric: in stock lengths 304.8, 609.6, and some styles 914.4 mm long

- Designed so you can segment to shorter custom lengths.
- Minimum segment size is the Gib Length (GL).
- Custom lengths available, specify.

**RBM 62:** 304.8 & 609.6 mm lengths in stock, 15.88 mm diameter rocker

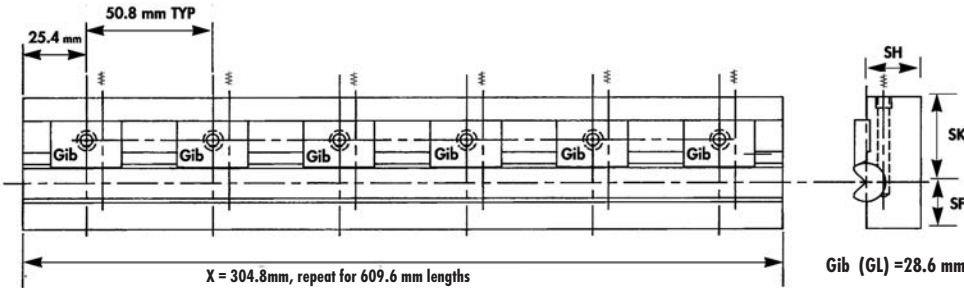

**RBM 100:** 304.8 & 609.6 mm lengths in stock, 25.4 mm diameter rocker

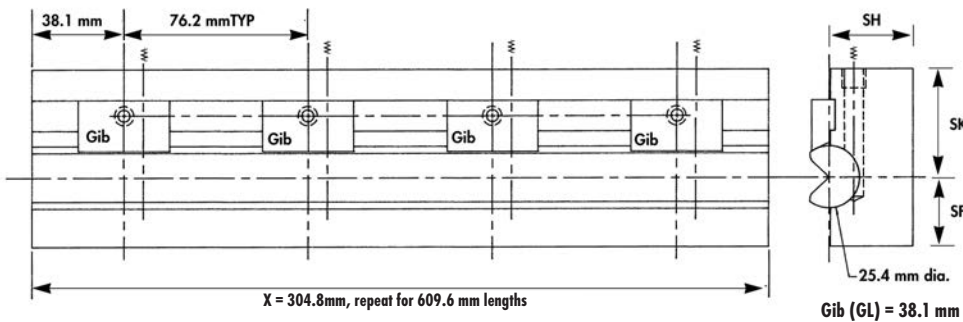

**RBM 150:** 304.8, 609.6 and 914.4 mm lengths in stock, 38.1 mm diameter rocker

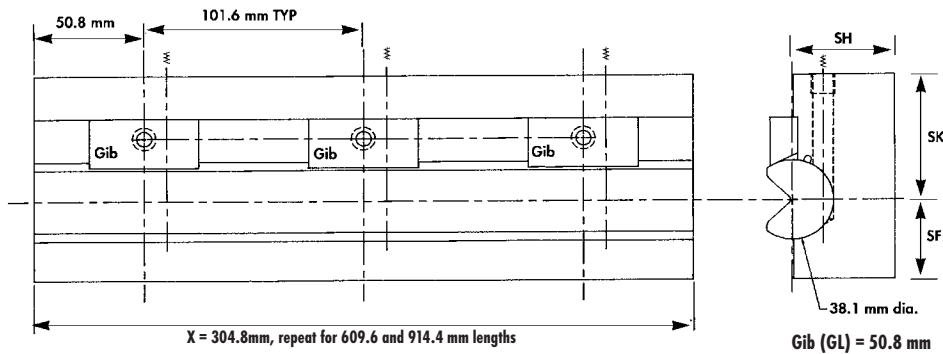

**RBM 200, 250 and 300:** 304.8, 609.6 and 914.4 mm lengths in stock, 50.8, 63.5 and 76.2 mm dia rockers

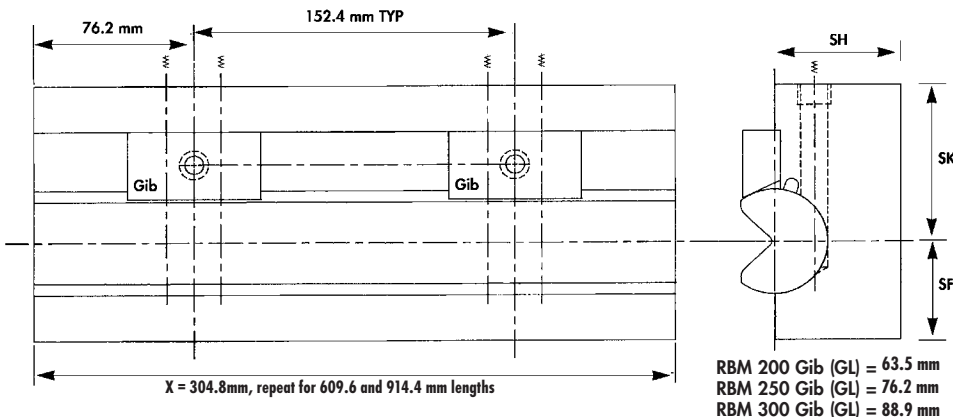

## Length Segmenting:

1. 304.8 mm lengths are shown (left). 609.6 and 914.4 mm lengths are a repeating pattern of the 304.8 mm length.
2. Minimum segmenting size is the GL (gib length) dimension. Each segment needs a gib to retain rocker. Spring returns are marked by  $\#$  and are under gibs.

## How to Segment:

1. Remove rocker by taking out set screw/lube fitting. Rotate rocker to remove the spring return plunger mechanism and rocker.
2. Rocker is fully hardened (Rc 56-62). Cut with wire machine or best way to precise length/size.
3. Saddle is machinable. Cut with wire machine or best way to precise length.
4. CAUTION: Thoroughly de-burr and clean saddle and rocker. Make sure no chips or dirt remain in saddle/rocker spring return pockets before reassembly.
5. Reassemble and check to make sure rocker returns easily when rotated.

## READY Can Segment:

1. You must purchase the entire 304.8, 609.6 or 914.4 mm length and specify the segment dimensions. The remaining pieces are shipped with the tooling unless specified otherwise. No rebates on unused pieces.
2. For precision cuts, call READY for pricing - 1-800-543-4355.

### Order Example:

| READY Model Callout | RBM 100<br>Rocker Diameter<br>25.4 mm | X = 609.6mm<br>Specify Length of Bender<br>609.6 mm |
|---------------------|---------------------------------------|-----------------------------------------------------|
|                     |                                       |                                                     |

$\#$  = spring return

GL = gib length

Flush mount lube fittings at end of spring return.





# READY High Production Benders - Metric

- Use whenever production exceeds a million parts, ideal for most stamping dies.
- In stock lengths, see page 17. Now available up to 914.4 mm long.
- For custom lengths, see page 18.

- Our highest production bender - now available up to 914.4 mm long.
- This is an inch product, the same as READY High Production Benders - Inch, on pages 6 to 8, except with metric mounting holes.

## Selecting Standard Benders:

1. Find the PT you are forming in top row of chart below. Read down (vertically) for all data. Verify the PH check (specials can bend shorter PH's).
2. Note minimum and maximum lengths (X) in chart below. Custom lengths are available. Use in stock lengths whenever possible for quick delivery. Longer lengths achieved by butting units end-to-end, .254 mm gap between.

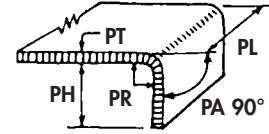

PT = part thickness  
PH = part height  
PR = part radius  
PA = part angle  
PL = part length

Standard benders form a 90° bend in mild steel. The PR should roughly equal the PT. If you have questions or need a special quotation, please email the worksheet on back cover with prints.

### Features:

1. **Rockers:** fully hardened (Rc 56 to 62), S-7 tool steel.
2. **Saddles:** fully hardened (Rc 48 to 52) A-2 steel. Counterbored mounting holes per patterns on pages 17 and 18. Flush mount lube fittings.
3. Rockers and saddles are CNC ground for precision and interchangeability.
4. Rocker angle is 87° on all standard benders. This allows for 3° of overbend to produce consistent 90° forms in mild steel. Harder steel or larger part radii may require more overbend. Rocker angles can be specified at time of order or altered by the diemaker. See page 10 about oversquare bends.

All dimensions are in millimeters.

| Part Material Thickness (PT)                                                         | 0.25 - 1                | 1 - 1.19                           | 1.9 - 3                  | 3 - 4.1        | 4.1 - 5.3      | 5.3 - 6.4      |
|--------------------------------------------------------------------------------------|-------------------------|------------------------------------|--------------------------|----------------|----------------|----------------|
| Part Height Check (PH)                                                               | 6.35                    | 9.9                                | 14.8                     | 19.7           | 24.6           | 29.5           |
| To use standard benders, PH should exceed these dimensions. Fax prints for specials. |                         |                                    |                          |                |                |                |
| In Stock Lengths, X = (see page 17)                                                  | 28.6<br>88.90<br>152.40 | 38.1<br>101.60<br>152.40<br>228.60 | 50.8<br>127.00<br>203.20 | 63.5<br>177.80 | 76.2<br>177.80 | 88.9<br>152.40 |
| Minimum Length (X) (Gib Length - GL)                                                 | 28.6                    | 38.1                               | 50.8                     | 63.5           | 76.2           | 88.9           |
| Maximum Length (X)                                                                   | 609.6                   | 609.6                              | 914.4                    | 914.4          | 914.4          | 914.4          |
| <b>MODEL CALLOUT</b>                                                                 | <b>RMC 62</b>           | <b>RMC 100</b>                     | <b>RMC 150</b>           | <b>RMC 200</b> | <b>RMC 250</b> | <b>RMC 300</b> |

## Standard READY High Production Bender - Metric

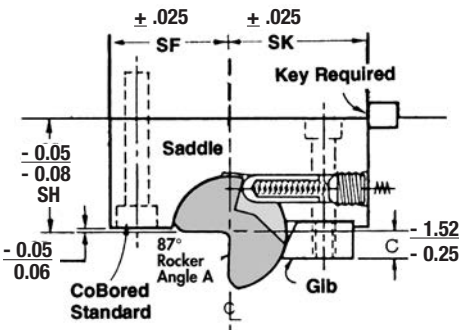

- Tapped mounting holes available as specials.

| Rocker Diameter (87° Angle) | 15.88 | 25.4  | 38.1  | 50.8   | 63.5   | 76.2   |
|-----------------------------|-------|-------|-------|--------|--------|--------|
| Saddle Width (SW)           | 53.98 | 73.03 | 98.42 | 123.83 | 149.23 | 174.63 |
| Saddle to Front (SF)        | 19.05 | 28.58 | 38.10 | 47.63  | 57.15  | 69.85  |
| Saddle to Key (SK)          | 34.93 | 44.45 | 60.33 | 76.20  | 92.08  | 104.78 |
| Saddle Height (SH)          | 22.23 | 34.93 | 47.63 | 60.33  | 73.03  | 85.73  |
| Gib Length (GL)             | 28.6  | 38.1  | 50.8  | 63.5   | 76.2   | 88.9   |
| <b>Rocker Dimensions</b>    |       |       |       |        |        |        |
| (B)                         | 5.39  | 8.61  | 12.90 | 17.22  | 21.54  | 25.83  |
| (C)                         | 4.95  | 7.93  | 11.89 | 15.85  | 19.81  | 23.77  |
| (J)                         | 6.24  | 9.98  | 14.97 | 19.96  | 24.95  | 29.94  |

**READY High Production Benders - Metric: in stock lengths**

- Our highest production bender.
- Custom lengths up to 609.6 or 914.4 mm long available, see page 18.
- This is an inch product, the same as READY High Production Benders - Inch, on pages 6 to 8, except with metric mounting holes.

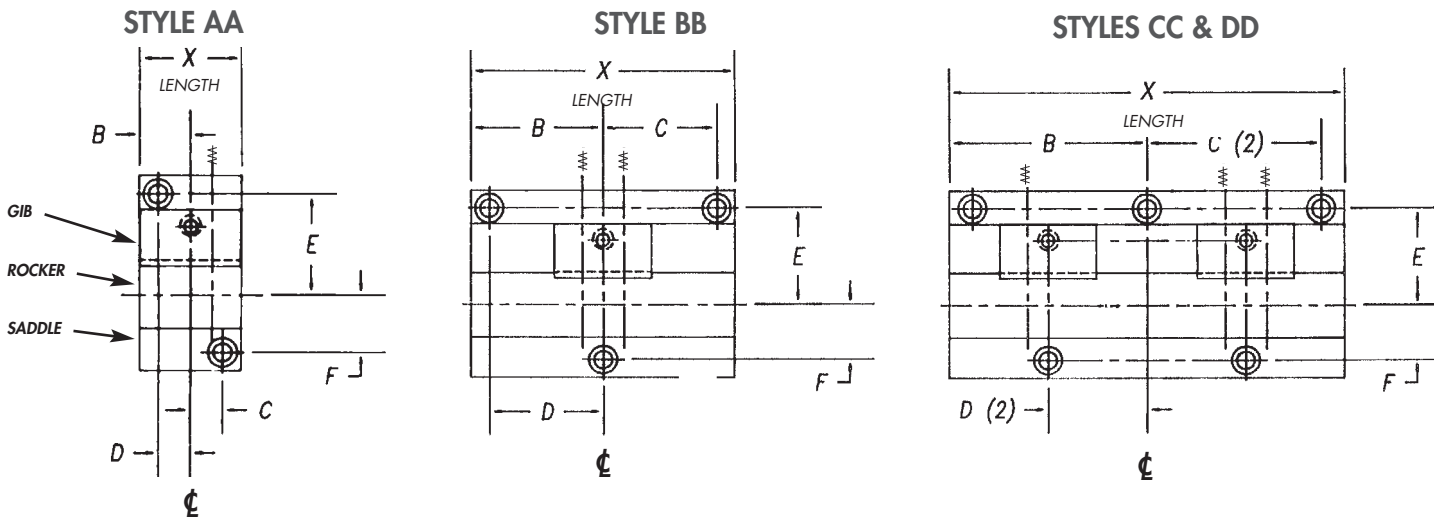

**Mounting Hole Locations**

| Model Callout | Length Style | X Length | B      | C      | D     | E     | F     | SHCS size |
|---------------|--------------|----------|--------|--------|-------|-------|-------|-----------|
| RMC 62        | AA           | 28.58    | 14.29  | 9.00   | 9.00  | 30.00 | 14.00 | M4        |
|               | CC           | 88.90    | 44.45  | 38.46  | 22.23 | 30.00 | 14.00 | M4        |
|               | DD           | 152.40   | 76.20  | 70.21  | 38.10 | 30.00 | 14.00 | M4        |
| RMC 100       | AA           | 38.10    | 19.05  | 12.00  | 12.00 | 37.50 | 21.50 | M6        |
|               | BB           | 101.60   | 50.80  | 44.25  | 44.25 | 37.50 | 21.50 | M6        |
|               | CC           | 152.40   | 76.20  | 67.18  | 38.10 | 37.50 | 21.50 | M6        |
|               | DD           | 228.60   | 114.30 | 105.31 | 57.15 | 37.50 | 21.50 | M6        |
| RMC 150       | AA           | 50.80    | 25.40  | 17.00  | 17.00 | 50.00 | 30.00 | M8        |
|               | BB           | 127.00   | 63.50  | 51.51  | 51.51 | 50.00 | 30.00 | M8        |
|               | CC           | 203.20   | 101.60 | 86.59  | 50.80 | 50.00 | 30.00 | M8        |
| RMC 200       | AA           | 63.50    | 31.750 | 21.50  | 21.50 | 65.00 | 37.50 | M10       |
|               | BB           | 177.80   | 88.90  | 73.89  | 73.89 | 65.00 | 37.50 | M10       |
| RMC 250       | AA           | 76.20    | 38.10  | 25.00  | 25.00 | 79.00 | 44.00 | M12       |
|               | BB           | 177.80   | 88.90  | 70.89  | 70.89 | 79.00 | 44.00 | M12       |
| RMC 300       | AA           | 88.90    | 44.45  | 32.50  | 32.50 | 92.50 | 57.00 | M12       |
|               | BB           | 152.40   | 76.20  | 58.19  | 58.19 | 92.50 | 57.00 | M12       |

**Tolerances Held**  
 X = saddle length  
 +0mm / -0.25mm;  
 X = rocker length  
 +0.25mm / -0mm;  
 Screw locations held  
 ± 0.13mm;

**Order Example:**

|                     |                         |                       |
|---------------------|-------------------------|-----------------------|
| <b>RMC</b>          | <b>100</b>              | <b>X = DD</b>         |
| READY Model Callout | Rocker Diameter 25.4 mm | Specify Length Bender |

All dimensions are in millimeters.

# READY High Production Benders - Metric: Custom Lengths

- READY's CNC grinding technology, delivers lengths up to 914.4 mm long at attractive prices.
- Longer lengths achieved by butting two or more units end-to-end, .25 mm gap.

- Now available up to 914.4 mm long.
- Specify your desired length (X) and READY will deliver.
- This is an inch product, the same as READY High Production Benders - Inch on pages 6 to 8, except with metric mounting holes.

**RMC 62, 100 and 150 Repeating Hole Patterns**  
(for 15.88, 25.4 and 38.1 mm Diameter Rockers)

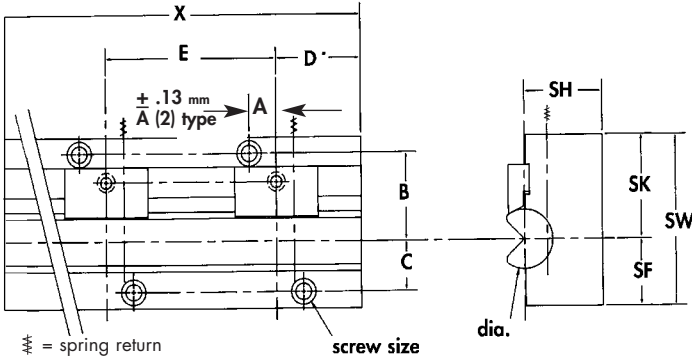

**RMC 200, 250 and 300 Repeating Hole Patterns**  
(for 50.8, 63.5, 76.2 mm Diameter Rockers)

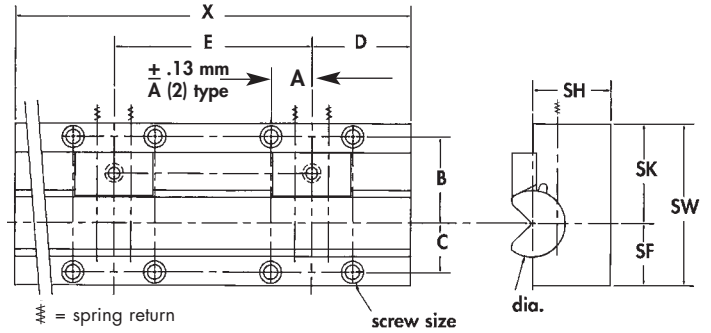

All dimensions are in millimeters, unless noted otherwise.

### Minimum/Maximum Lengths:

- Charts and drawings showing hole locations, etc., start at nominal lengths. Custom lengths start very short, at catalog Gib Length (GL) dimensions.
- Mounting hole patterns for shorter, custom lengths are available upon request by application.
  - RMC 62** Minimum 29 mm (GL) Maximum 609.6 mm
  - RMC 100** Minimum 39 mm (GL) Maximum 609.6 mm
  - RMC 150** Minimum 51 mm (GL) Maximum 914.4 mm
  - RMC 200** Minimum 64 mm (GL) Maximum 914.4 mm
  - RMC 250** Minimum 77 mm (GL) Maximum 914.4 mm
  - RMC 300** Minimum 89 mm (GL) Maximum 914.4 mm

3. PLEASE NOTE: Standard in stock lengths of READY High Production Benders are cataloged on page 17. These ship fast and cost less. The READY Bender® - Metric, pages 14 and 15, is available in custom lengths and can further reduce your tooling budget.

NOTE:

- Counterbored holes standard, tapped available as specials.

| Model and Rocker Diameter | X Length                    | A     | B     | C     | D      | E     | SHCS size |
|---------------------------|-----------------------------|-------|-------|-------|--------|-------|-----------|
| RMC 62 15.88mm dia.       | lengths<br>152.4 - 305 mm   | 9.00  | 30.00 | 14.00 | X / 8  | X / 4 | M4        |
| RMC 100 25.4mm dia.       |                             | 12.00 | 37.50 | 21.50 | X / 8  | X / 4 | M6        |
| RMC 150 38.1mm dia.       |                             | 17.00 | 50.00 | 30.00 | X / 6  | X / 3 | M8        |
| RMC 62 15.88mm dia.       | lengths<br>317.5 - 609.6 mm | 9.00  | 30.00 | 14.00 | X / 12 | X / 6 | M4        |
| RMC 100 25.4mm dia.       |                             | 12.00 | 37.50 | 21.50 | X / 12 | X / 6 | M6        |
| RMC 150 38.1mm dia.       |                             | 17.00 | 50.00 | 30.00 | X / 10 | X / 5 | M8        |
| RMC 62 15.88mm dia.       | lengths<br>622.3 - 914.4 mm | 9.00  | 30.00 | 14.00 | X / 16 | X / 8 | M4        |
| RMC 100 25.4mm dia.       |                             | 12.00 | 37.50 | 21.50 | X / 16 | X / 8 | M6        |
| RMC 150 38.1mm dia.       |                             | 17.00 | 50.00 | 30.00 | X / 14 | X / 7 | M8        |
| RMC 200 50.8mm dia.       | lengths<br>203.2 - 305 mm   | 31.50 | 66.00 | 37.50 |        |       | M10       |
| RMC 250 63.5mm dia.       |                             | 35.00 | 79.00 | 44.00 | X / 4  | X / 2 | M12       |
| RMC 300 76.2mm dia.       |                             | 40.00 | 92.50 | 57.00 |        |       | M12       |
| RMC 200 50.8mm dia.       | lengths<br>317.5 - 609.6 mm | 31.50 | 66.00 | 37.50 |        |       | M10       |
| RMC 250 63.5mm dia.       |                             | 35.00 | 79.00 | 44.00 | X / 6  | X / 3 | M12       |
| RMC 300 76.2mm dia.       |                             | 40.00 | 92.50 | 57.00 |        |       | M12       |
| RMC 200 50.8mm dia.       | lengths<br>622.3 - 914.4 mm | 31.50 | 66.00 | 37.50 |        |       | M10       |
| RMC 250 63.5mm dia.       |                             | 35.00 | 79.00 | 44.00 | X / 10 | X / 5 | M12       |
| RMC 300 76.2mm dia.       |                             | 40.00 | 92.50 | 57.00 |        |       | M12       |

Selecting the right Bender is as easy as 1...2...3

Email this worksheet for **FAST QUOTES**

benders@ReadyTechnology.com - send part prints

**1** Company: \_\_\_\_\_  
 Contact Name: \_\_\_\_\_ Title: \_\_\_\_\_  
 Address: \_\_\_\_\_  
 City, State, Zip: \_\_\_\_\_  
 Telephone: \_\_\_\_\_ Fax: \_\_\_\_\_  
 Email Address: \_\_\_\_\_

**2 Please describe your application**

This will be formed in (please check)

Stamping Die  Automated Machine  Press Brake, tonnage of press brake \_\_\_\_\_

Here are some of the most popular applications:

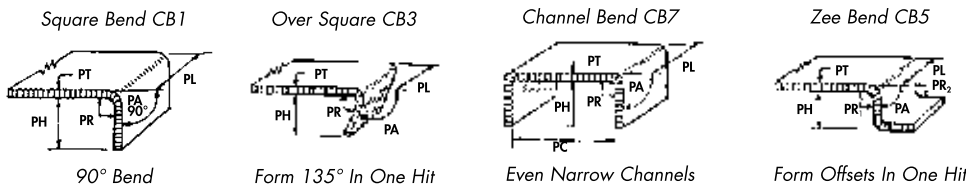

Annual production \_\_\_\_\_

Type of material formed \_\_\_\_\_

Tensile strength \_\_\_\_\_

CB = Classified Bend # \_\_\_\_\_

PT = Part Material Thickness \_\_\_\_\_

PL = Part Length (bent leg) \_\_\_\_\_

PA = Part Angle (degrees of bend) \_\_\_\_\_

PH = Part Height (bent leg) \_\_\_\_\_

PR = Part Radius \_\_\_\_\_

PC = Part Channel (inside) \_\_\_\_\_

PF = Part Flange \_\_\_\_\_

Are tool marks\* on part acceptable?

\*We specialize in forming even prepaint without tool marks.

**Notes**

**3 Please Quote:**

**Stamping Dies**

- Ready makes determination
- The READY Bender
- Ready High Production Bender
- Ready Bender - Metric
- Ready High Production Bender - Metric
- Compact Benders

**Press Brake Tooling**

- Rotary Bender Press Brake Tools
- Conventional Vee Die Brake Tools
- Special Brake Tooling per print

**READY TECHNOLOGY, INC.**

333 Progress Rd. • Dayton, OH 45449 • 937-866-7200 • 800-543-4355

www.readytechnology.com

**Classified Bends (CB)**

