

READY

THE INNOVATOR OF OUR INDUSTRYSM

HYDROCAM[®]

The Ultimate in Flexible Cam Design



HYDROCAM is Protected by U.S. and International Patents

HYDROCAM® - The Ultimate in Flexible Cam Design

Simple, Proven & Reliable

HYDROCAM® is:

- Ideal for piercing, forming or flanging requirements.
- In stock for fast delivery.
- **Powerful.** One **H-1** can serve up to four identical **H-2** units.
- **Versatile.** Mount the **H-2** at any angle up to six feet away from **H-1**.
- **Forceful.** The **H-2** can deliver from 1.6 to 26 metric tons of force.
- **The Most Complete Line.** **H-2** units are available with 25, 50, 75 and 100 mm stroke lengths depending on model selected.

We've Changed the World of Cams! **HYDROCAM®** systems are reshaping the way metal stamping dies are designed and operated. They are simple to install and operate, and yet this innovative product, engineered and first brought to the market by READY Technology, does so much to take complexity out of die design. With **HYDROCAM®**, many dies suddenly become a lot simpler, and thanks to **HYDROCAM®**, fewer dies are now required for part manufacture.

Here's How They Work: The vertical action of the press is transferred into a precise cam action using patented hydraulic technology. As the press ram lowers, it makes contact with the piston rod of the pump of **HYDROCAM®** (we call the pump the **H1** unit), at which point oil from the pump is transferred through one or more high pressure hoses to one or more piercing or forming units (we call these **H2** units). The **H2** units do the work and pierce or form the stamping part. The **H2** units then return to their original position after completing their work by means of nitrogen gas pressure which is regulated by an adjustable return built into the units. Simple, innovative, and yes, so versatile.

Yes, so Versatile! The beauty of **HYDROCAM®** lies in its versatility. The **H2** unit can be positioned into locations previously unreachable with classic mechanical dies at virtually any angle, up or down, to meet your piercing and forming requirements. Ask yourself the question: How can I design **HYDROCAM®** into my tool? More and more die designers are designing **HYDROCAM®** into their tools and are reducing cost to their customers in the process.

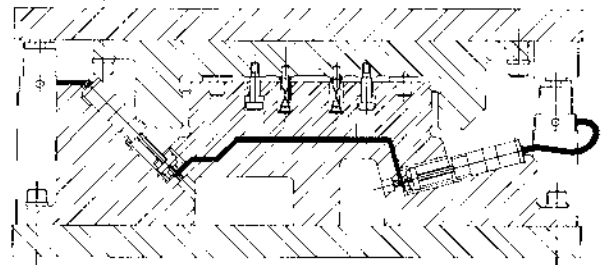

Automotive die . . . piercing

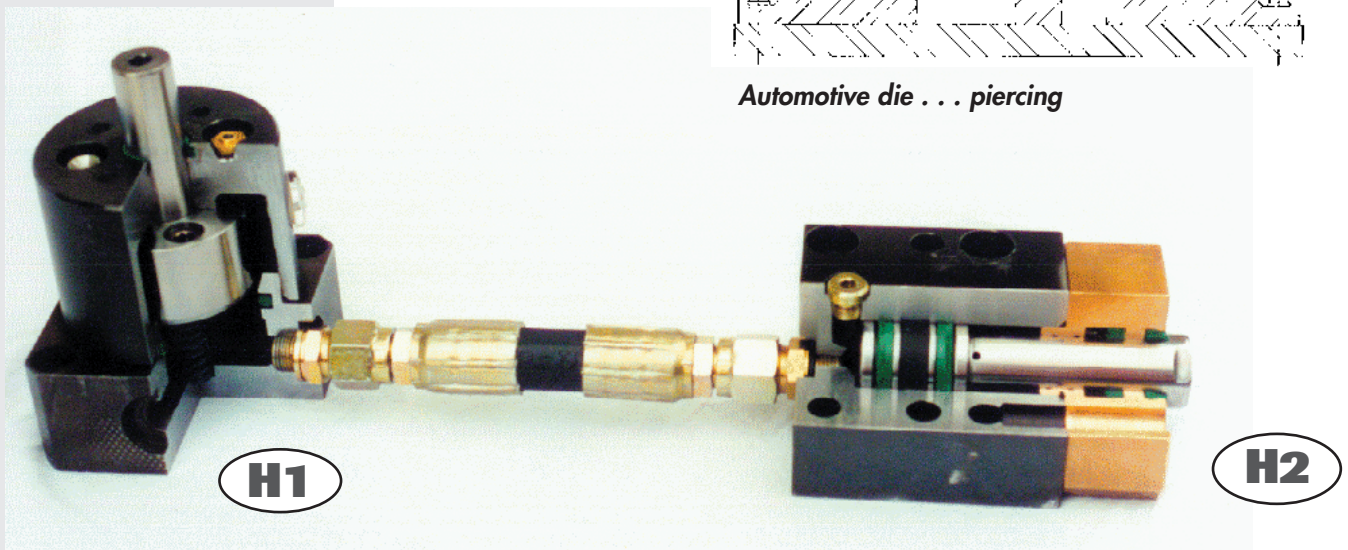

NOTE: **HYDROCAM®**'s unique design eliminates the thrusting force of the ram/slide from the cam station, allowing the use of standard L-GIBS to position and guide the station. Providing a guidance system for a **HYDROCAM®** driven cam station is the responsibility of the customer. Neither, the H2 unit's piston rod, nor its front mounting plate assembly is designed to provide cam station guidance. Contact your representative for application support.

HYDROCAM® Is Powerful, Compact and Reliable, and Oh, Yes, It's Interchangeable!

Powerful - Our patented design provides more force than any other cam of its kind. **H2** piercing/forming units are available in seven sizes providing up to 26 metric tons of force, giving you powerful force where you need it.

Compact - Our unique low profile design for the **H2** units make installations in tight areas possible. The ability to mount the **H1** unit up to six feet away from the **H2** unit makes this the cam of choice for transfer dies by avoiding interference with drivers and aerial tooling blocks.

Reliable - There are hundreds of **HYDROCAM®** systems operating worldwide today, reliably stamping parts and meeting demanding production schedules. **HYDROCAM®** was the first hydraulic cam of its kind to come to market, and more **HYDROCAM®** systems make parts for more customers than any competing brand.

Interchangeable - We carry a large inventory of all sizes of **H1** and **H2** units. If a die crashes, or other reasons require replacement of any **HYDROCAM®** unit, we provide the service and support to get your production back up and running quickly.

Ideal for retrofits and engineering changes



Before

- Costly and complicated mechanical cams.
- Increased maintenance costs due to mechanical wear.

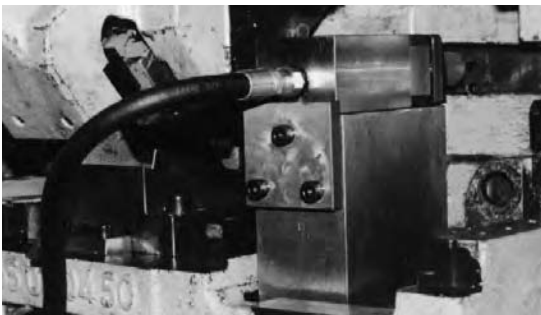

After

- **HYDROCAM®** makes retrofits easy.
- Decreased maintenance costs and downtime.

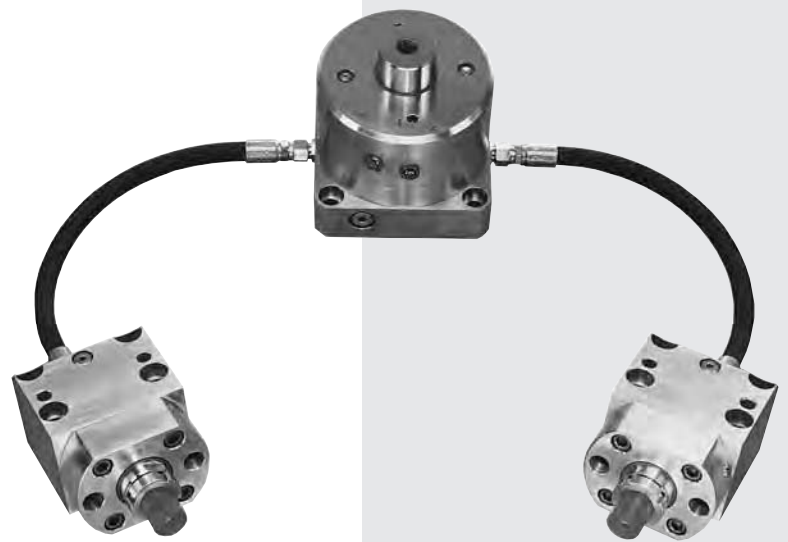

HYDROCAM® system with direct punch option units.

Selecting a HYDROCAM® System 4

HYDROCAM® H-2 Piercing/Forming Unit Specifications 6

HYDROCAM® H-1 Pump Specifications 8

HYDROCAM® System Calculations..... 10

HYDROCAM® H-1 and H-2 Cutaway Photos 11

HYDROCAM® Options 12

HYDROCAM® Design and Installation Guide 12

HYDROCAM® Accessories .. 16

HYDROCAM® Examples 19

HYDROCAM® Fax Worksheet 20

How To Select a HYDROCAM® System for Your Application

Basic Selection:

1. Determine tonnage required (piercing or forming force, plus stripping force), per unit to perform the necessary work. Note when using urethane or other mechanical methods for stripping, please add the appropriate stripping force.
2. After you calculate the forces, select the correct **H-2** unit(s) required to do the work. Do not exceed 90% of the **H-2** unit's available de-rated force (rated force, less return system force) from the chart below. Include the proper stroke length needed for each unit (see pages 6 and 7 for available stroke lengths).
3. Determine the correct size and number of **H-1** pump(s). Group identical **H-2** units together (tonnage and stroke), performing identical work (piercing, forming of flanging). One **H-1** pump can operate up to four identical **H-2** piercing/forming units (see chart on page 5).

Force of H2 Piercing/Forming Unit

This chart shows the effect of a nitrogen or oil return system on the force rating of each **H2** unit.

Standard Rate equals the effect of standard (minimum) return force at 100 bar (1,450 psi) on the **H2** unit's force. Ideal for piercing applications that use a customer-provided stripper.

Maximum Rate equals the effect of maximum return force at 150 bar (2,175 psi) on the **H2** unit's force. Ideal for multiple piercing applications, special shape piercing, all forming and flanging.

H-2		Model 2	Model 3.2	Model 5	Model 7.8	Model 12.5	Model 20	Model 31
Std. Rate	daN	1,787	2,885	4,545	7,094	11,319	18,819	28,817
	Metric tons	1.8	2.9	4.5	7	11.3	18.8	28.8
Std. Rate	lbf.	3,932	6,346	10,002	15,611	24,906	41,440	63,439
	USA tons	2	3.2	5	7.8	12.5	20.7	31.7
Max Rate	daN	1,698	2,728	4,319	6,740	10,742	18,230	27,727
	Metric tons	1.7	2.7	4.3	6.7	10.7	18.2	27.7
Max Rate	lbf.	3,732	5,993	9,494	14,815	23,609	40,115	60,989
	USA tons	1.9	3	4.7	7.4	11.8	20	30

Working Example: To pierce two holes, 0.250 inch diameter, through 0.125 thick mild steel, with 50,000 psi minimum tensile strength. We selected a 25mm stroke length for this example. (The working example uses piercing as the HYDROCAM application. HYDROCAM is also ideal for forming, flanging and other applications.)

Step 1 Calculate the force.

$$\text{Force} = (\text{Hole } \varnothing \times (\pi = 3.1416) \times \text{material thickness} \times \text{material tensile strength}) + \text{recommended 10\% stripping force}$$

English example: (.250 in. X 3.1416 X .125 in. X 50,000 psi) + 10% = 4,909 lbs. + 491 lbs. = 5400 lbs. (÷ 2000 lbs. = 2.7 U.S. tons)

Metric example: (6mm X 3.1416 X 3mm X 40 daN per mm²) + 10% = 2,262 daN + 226 daN = 2,488 daN (÷ 1000 N = 2.5 metric tons)

Step 2 Select the rate. In this example use the standard rate for piercing.

Step 3 Apply the Rule of Ninety: Never exceed 90% of the rated force. 5400 lbs. ÷ 0.90 = 6000 lbs.

Step 4 Read across the above chart until the rated force exceeds your Rule of Ninety value. In this example 6,346 lbs. exceeds 6000 lbs.

Step 5 Read up to the column heading. This is the H2 model you need. In this example, H2 model 3.2.

Example Chart

H-2		Model 2	Model 3.2
Std. Rate	daN	1,787	2,885
	Metric tons	1.8	2.9
Std. Rate	lbf.	3,932	6,346
	USA tons	2	3.2
Max Rate	daN	1,698	2,728
	Metric tons	1.7	2.7
Max Rate	lbf.	3,732	5,993
	USA tons	1.9	3

Annotations: Step 2 points to the 'Std. Rate' row. Step 4 points to the '6,346' value. Step 5 points to the 'Model 3.2' column header.

FORCE WARRANTY: The minimum force that a **H2** Piercing/Forming unit is warranted to provide is listed in the maximum rate column. If the customer's determined application force for a cam station's tonnage exceeds 90% of the maximum rate force, the next larger or multiple **H2** unit(s) must be selected.

HYDROCAM® H1 Pump Selection Chart

This chart determines the appropriate **H1** Pump for the **H2** unit(s) selected. The chart also lists the **H1** Pump's piston rod travel (mm) next to the number of identical **H2** units served.

You need to know the **H2** model number, the number of **H2** units required and the **H2** stroke length before using this chart.

Always use the Rule of Ninety. The chart is based on using ninety percent of the total volume (VT) of the **H1** Pumps listed, in determining the number of identical **H2** units that can be supplied by an **H1** pump.

Different stroke lengths or different **H2** models may not be used with the same **H1** Pump. No more than four **H2** units may operate off a single **H1** Pump.

When two or more identical **H2** units are used to extend a gang pierce bar or forming pad, each **H2** unit must have its own **H1** Pump.

NOTE: Piston rod travel may vary slightly. This results from normal variations in connecting hose length(s), and the number and style of the turning fittings.

Use only approved hose and fittings.

Working Example:

H-2	H-1	Model 5
Model 2	25 mm	1 (12.99) 2 (18.49) 3 (23.98)
	50 mm	1 (18.49)
Model 3.2	25 mm	1 (16.47) 2 (25.44)
	50 mm	1 (25.44)
	75 mm	

Step 1 → Step 2 → Step 3 ← Step 4 ←

H-2	H-1	Model 5	Model 8	Model 13	Model 20	Model 40	Model 66
Model 2	25 mm	1 (12.99) 2 (18.49) 3 (23.98)	4 (22.26)				
	50 mm	1 (18.49)	2 (22.26) 4 (37.02)	3 (29.64)			
Model 3.2	25 mm	1 (16.47) 2 (25.44)	3 (25.57)	4 (31.60)			
	50 mm	1 (25.44)	1 (19.55) 2 (31.60)	2 (31.60) 3 (22.79) 4 (27.88)			
	75 mm		1 (25.57)	1 (25.57)	2 (22.79) 3 (30.43)	4 (25.59)	
Model 5	25 mm	1 (21.63)	2 (26.48)	3 (35.96)	4 (23.55)		
	50 mm		1 (26.48)	1 (26.48)	2 (23.55) 3 (21.74) 4 (26.49)		
	75 mm			1 (35.96)	1 (19.54)	2 (21.74) 3 (28.86)	4 (35.99)
Model 7.8	25 mm		1 (22.33)	2 (37.17)	3 (26.32)	4 (22.35)	
	50 mm			1 (37.17)	1 (20.05)	2 (22.35) 3 (29.77)	4 (37.19)
	75 mm				1 (26.32)	2 (29.77) 3 (40.90) 4 (52.04)	
Model 12.5	25 mm			1 (30.92)	2 (27.31)	3 (25.08) 4 (30.94)	
	50 mm				1 (27.31)	2 (30.94)	3 (42.65)
	75 mm					1 (25.08)	2 (42.65)
	100mm					1 (30.94)	1 (30.94)
Model 20	25 mm				1 (23.52)	2 (26.45) 3 (35.93) 4 (45.41)	
	50 mm					1 (26.45)	2 (45.41)
	75 mm					1 (35.93)	1 (35.93)
	100mm						1 (45.41)
Model 31	25 mm					1 (22.29) 2 (37.08) 3 (51.87)	
	50 mm						1 (37.08)
	75 mm						1 (51.87)
	100mm						special

Here is what you need to order:

QTY	PRODUCT DESCRIPTION
2	H-2-3.2 Piercing unit with 25mm stroke and front plate
1	H-1-5 Pump with stroke gauge ring
1	RT-2175-CP Nitrogen Control Panel
2	RT701810670-6 Hydraulic Hose 6 foot long with swivel fittings (specify lengths up to 6 foot)
2	RT52041JC55-6 Nitrogen Hose 6 foot long with swivel fittings (specify lengths up to 6 foot)

Note:

- Nitrogen return is standard, oil return can be specified as an option.
- Front plate is standard, direct punch can be specified as an option.
- Straight fittings will be supplied to connect the hoses when ordered as a system, elbow fittings can be specified as an option.

Step 1 and 2 Locate the **H2** unit and its stroke. In this example: model 3.2, stroke 25mm.

Step 3 Locate the number of **H2** units to the right of the stroke length. The **H1** Pump's piston rod travel (in millimeters) is listed next to that number in parentheses.

Step 4 Read up to the column heading. This is the **H1** model you need. In this example: **H1**, model 5.

HYDROCAM® H2 Piercing/Forming Unit

Compact Power with User Flexibility

Standard Features:

- **H-2** unit comes with adjustable nitrogen return force. A control panel must be ordered to take full advantage of this feature.
- Machinable front plate for customers to mount their tooling.

Popular Options:

- **Direct Punch Option.** Piston rod will accept a head type punch. Punch size and shank limitations are noted on the **H-2** dimension chart, see *D8* below.
- **Oil Return Option.** Used on special applications. See page 12 for details.

Mounting Suggestions:

- Locate the **H-2** unit in any orientation.
- Provide for hose access to the back and right front side of the **H-2** unit.
- Provide a mounting platform that will support three times the total force of the **H-2** unit.
- Locate the **H-2** unit against a thrust key.
- The **H-2** unit's piston rod is designed to extend fully each stroke.
- The **H-2** unit is designed to provide force, not guidance. As with any air, hydraulic or nitrogen cylinder, neither the H-1 Pump nor the H-2 unit is designed to withstand side-thrust forces. Properly guiding the tool and cam station will minimize wear to the cylinders and increase seal life. This is especially true in applications with long strokes, heavy or large tooling mounted, or in applications that approach the work in a non-perpendicular presentation.

H2 Piercing/Forming Unit Dimensions

H-2		Model 2	Model 3.2	Model 5	Model 7.8	Model 12.5	Model 20	Model 31
Metric Force	Per Unit	2 ton	3.2 ton	5 ton	7.8 ton	12.5 ton	20 ton	31 ton
L1 stroke 25 mm	mm inch	108 4.252	128 5.039	141 5.551	149 5.866	172 6.772	190 7.480	211 8.307
L1 stroke 50 mm	mm inch	133 5.236	154 6.063	166 6.535	174 6.850	197 7.756	215 8.465	236 9.291
L1 stroke 75 mm	mm inch	N/A	179 7.047	191 7.520	199 7.835	222 8.740	240 9.449	261 10.276
L1 stroke 100 mm	mm inch	N/A	N/A	N/A	N/A	247 9.724	265 10.433	286 11.260
L2	mm inch	8 .315	10 .394	10 .394	12 .472	15 .591	15 .591	20 .787
L3	mm inch	36 1.417	52 2.047	55 2.165	64 2.520	64 2.520	77 3.031	82 3.228
L4	mm inch	31 1.221	42 1.654	45 1.772	48 1.890	55 2.165	63 2.480	70 2.756
L5 stroke 25 mm	mm inch	101 3.976	120 4.724	132 5.197	138 5.433	158 6.220	172 6.772	190 7.480
L5 stroke 50 mm	mm inch	126 4.961	145 5.709	157 6.181	163 6.417	183 7.205	197 7.756	215 8.465
L5 stroke 75 mm	mm inch	N/A	170 6.693	182 7.165	188 7.402	208 8.189	222 8.740	240 9.449
L5 stroke 100 mm	mm inch	N/A	N/A	N/A	N/A	233 9.173	247 9.724	265 10.433
L6	mm inch	12 .472	15 .591	20 .787	22 .866	25 .984	30 1.181	35 1.378
L7	mm inch	6 .236	8 .315	10 .394	12 .472	16 .630	20 .787	24 .945
L8	mm inch	N/A	17 .669	20 .787	21 .827	32 1.260	38 1.496	48 1.890
L9	mm inch	N/A	6 .236	8 .315	9 .354	14 .551	15 .591	17 .669
B1	mm inch	60 2.362	75 2.953	85 3.346	100 3.54	130 5.118	140 5.512	180 7.087
B2	mm inch	44 1.732	55 2.165	65 2.559	76 2.992	100 3.937	110 4.331	140 5.512
B3	mm inch	59 2.323	74 2.913	84 3.307	99 3.898	129 5.079	139 5.472	179 7.047
Ht 1	mm inch	50 1.969	60 2.362	70 2.756	80 3.150	100 3.937	110 4.331	150 5.906
Ht 2	mm inch	25 .984	30 1.181	35 1.378	40 1.575	50 1.969	55 2.165	75 2.953
Ht 3	mm inch	49 1.929	59 2.323	69 2.717	79 3.110	99 3.898	109 4.291	149 5.866
D1 Ø	mm inch	20 .787	25 .984	32 1.260	40 1.575	50 1.969	70 2.756	85 3.346
D2 (x2) Ø	mm	8 H7	10 H7	10 H7	12 H7	12 H7	16 H7	20 H7
D3 (x2) Ø	mm	10	12	14	16	20	20	24
D4 Ø		M12 x 1.0	M16 x 1.5	M20 x 1.5	M30 x 2.0	M36 x 2.0	M48 x 2.0	M56 x 2.0
D5 Ø	mm inch	15 .591	18 .709	20 .787	26 1.024	26 1.024	32 1.260	32 1.260
D6 (x4) Ø	metric	M8	M10	M10	M12	M16	M16	M20
D7 Piston Ø	mm inch	25 .984	32 1.260	40 1.575	50 1.969	63 2.480	80 3.150	100 3.937
D8 Nominal Head Punch Shank Ø	mm	N/A	13 10	16 13	23 20	28 25	35 32	43 40
D9 Thread Size of Bolt		M8	M10	M12	M16	M16	M20	M20
G Ø	BSP	G 1/4	G 3/8	G 3/8	G 3/8	G 3/8	G 3/8	G 3/8

All dimensions are nominal unless tolerance is stated.

H-2		Model 2	Model 3.2	Model 5	Model 7.8	Model 12.5	Model 20	Model 31
Metric Force	Per Unit	2 ton	3.2 ton	5 ton	7.8 ton	12.5	20 ton	31 ton
De-rated Force	daN lbf.	1787 3932	2885 6346	4545 10,002	7094 15,611	11,319 24,906	18,819 41,440	28,817 63,439
VC Volume/str.(mm)	cm³ inch ³	0.491 0.0300	0.804 0.0491	1.257 0.0767	1.963 0.1198	3.117 0.1902	5.027 0.3067	7.854 0.4793
Max Force at 400 bar (5802 PSI)	daN lbs.	1,963 4,328	3,198 7,050	4,998 11,020	7,801 17,200	12,473 27,500	19,998 44,090	30,997 68,340
Volume (stroke 25 mm)	cm³ inch ³	12.27 0.749	20.11 1.227	31.42 1.917	49.09 2.995	77.93 4.756	125.66 7.668	196.35 11.982
Volume (stroke 50 mm)	cm³ inch ³	24.54 1.498	40.21 2.454	62.83 3.834	98.17 5.991	155.86 9.511	251.33 15.337	392.70 23.964
Volume (stroke 75 mm)	cm³ inch ³	N/A	60.32 3.681	94.25 5.751	147.26 8.986	233.79 14.267	376.99 23.005	589.05 35.946
Volume (stroke 100 mm)	cm³ inch ³	N/A	N/A	N/A	N/A	311.72 19.023	502.65 30.674	785.40 47.928
Standard Min. Return Force at 100 bar (1,450 PSI)	daN lbf.	176 396	313 704	453 1,018	707 1,589	1,154 2,594	1,179 2,650	2,180 4,901
Max. Return Force at 150 bar (2,175 PSI)	daN lbf.	265 596	470 1,056	679 1,526	1,061 2,385	1,731 3,891	1,768 3,975	3,270 7,351

NOTE: De-rated Force equals maximum force less standard (minimum) return force.

See H-2 dimension chart on previous page. All figures are nominal unless tolerance is stated.

Forces are rated in metric tons (1 metric ton = 1.1 U.S. ton)

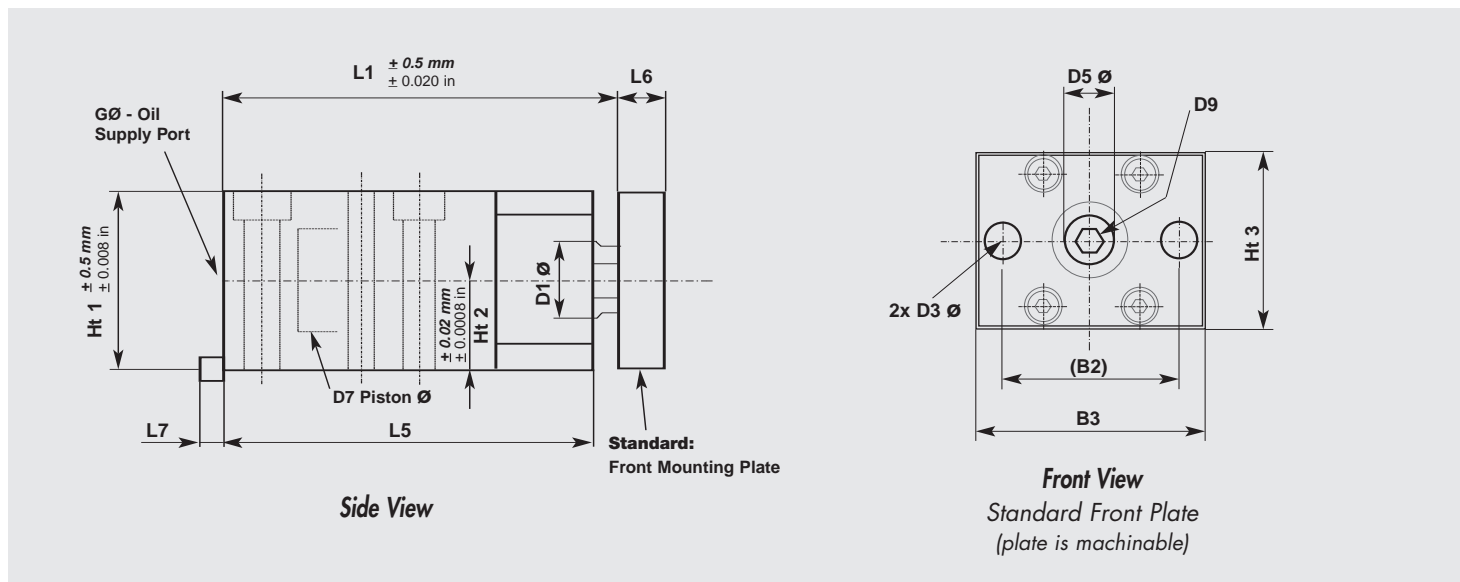
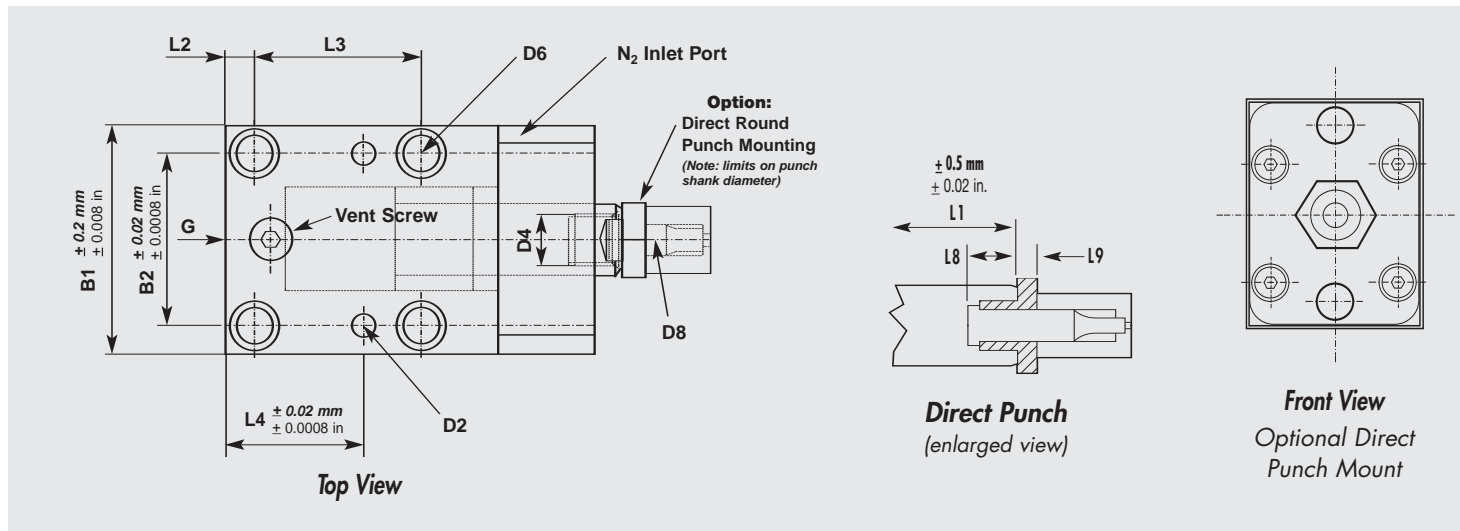

HYDROCAM H-1 Pump

READY recommends **using only a premium grade of hydraulic oil.**

The **H-1** pump is available in six standard sizes. Each pump has four ports to activate up to four identical **H-2** units. The quantity, size, and stroke length of the **H-2** units hoses to each pump determines the size and oil volume of the pump needed. Pumps can be up to six feet away from **H-2** units. This allows you to free up critical die space and balance die loads.

Piston Rod Travel

Piston rod travel controls oil volume going to the **H-2** unit(s). Our selection chart on page 5 provides the dimension for you. See page 10 for this calculation.

Optional Stroke Gauge Ring

Used as a visual gauge to assist in set-up. Ring is located on top of pump body and made to the appropriate height based upon piston rod travel calculation.

This stroke gauge ring is not a stop block and should be used for set-up purposes only. See page 10 for this calculation.

Mounting Suggestions:

- The **H-1** pump's piston rod must be up and perpendicular to the ram.
- **H-1** pump must be located at or above the **H-2** unit's elevation.
- Locate the **H-1** anywhere in the die under the ram that provides ram balance and simple hose access to the **H-2** unit(s).
- Locate the **H-1** pump within six feet of the **H-2** unit(s).
- **Always use stop blocks.**
- **Die storage blocks are recommended.**
- **Never store pump with piston rod depressed or upside down.**

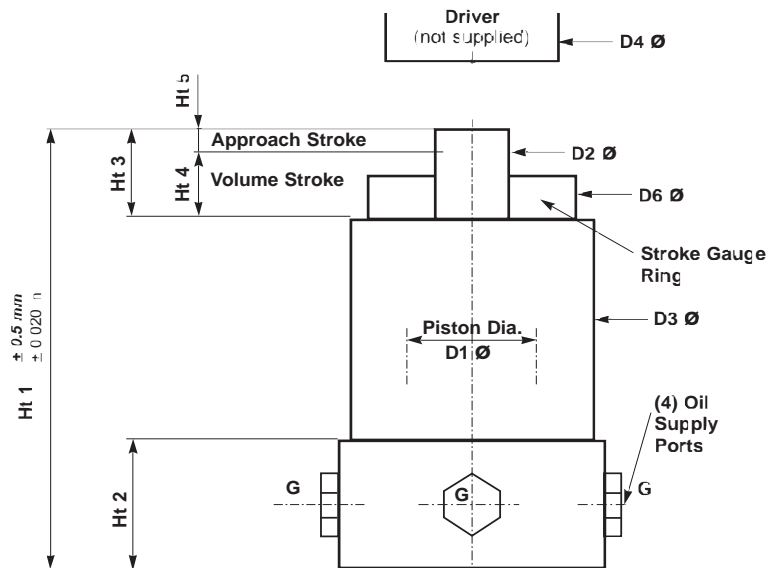
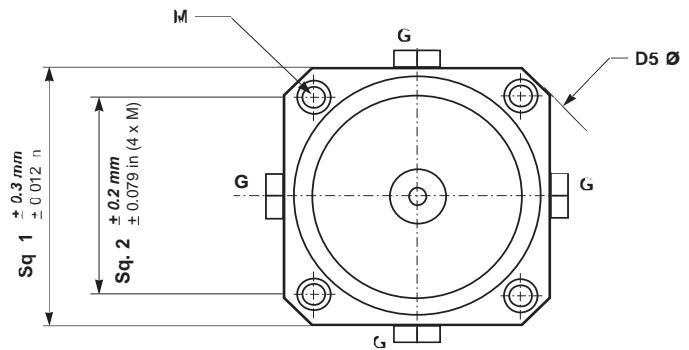

Required position of H-1 as compared to H-2

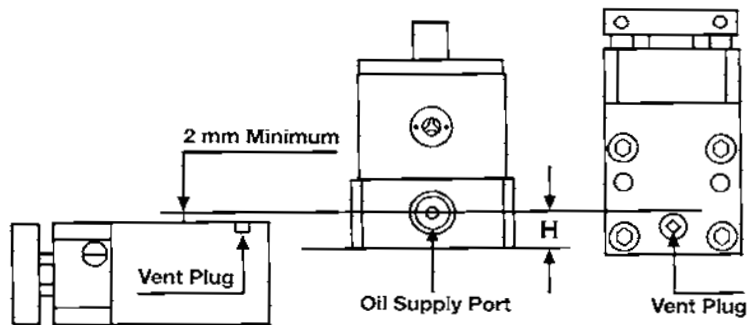

Model	H dimension
HYDROCAM H1-5	21 mm (0.83 in)
HYDROCAM H1-8	25 mm (0.98 in)
HYDROCAM H1-13	25 mm (0.98 in)
HYDROCAM H1-20	25 mm (0.98 in)
HYDROCAM H1-40	30 mm (1.18 in)
HYDROCAM H1-66	40 mm (1.57 in)

NOTE: READY understands that a few applications will exceed this guide. Contact your READY representative for application support.

H-1		Model 5	Model 8	Model 13	Model 20	Model 40	Model 66
VT Total Volume	cm³ inch ³	50 3.051	80 4.882	130 7.933	200 12.205	400 24.409	660 40.275
V1 Vol./Stroke per mm	cm³	2.235	3.318	3.318	7.854	13.273	13.273
V1 Vol./Stroke per inch	inch³	3.4636	5.1434	5.1434	12.1737	20.5735	20.5735
Ht 1	mm	133	145	195	166	195	275
Die Open Height	inch	5.236	5.709	7.677	6.535	7.677	10.827
Ht 2	mm	41	42	57	46	50	70
Height of Base	inch	1.614	1.654	2.244	1.811	1.969	2.756
Ht 3	mm	31	32	47	34	38	58
Total Stroke	inch	1.220	1.260	1.850	1.339	1.496	2.283
Ht 4 max.	mm	23	24	39	26	30	50
Volume Stroke	inch	0.906	0.945	1.535	1.024	1.181	1.969
Ht 5	mm	8	8	8	8	8	8
Approach Stroke	inch	0.315	0.315	0.315	0.315	0.315	0.315
D1 Ø	mm	53.34	65	65	100	130	130
Piston Diameter	inch	2.100	2.559	2.559	3.937	5.118	5.118
D2 Ø	mm	20	25	25	50	60	60
Rod Diameter	inch	0.787	0.984	0.984	1.969	2.362	2.362
D3 Ø	mm	82	100	100	147	182	182
Body Diameter	inch	3.228	3.937	3.937	5.787	7.165	7.165
D4 min. Ø	mm	45	55	55	95	120	120
(not supplied)	inch	1.772	2.165	2.165	3.740	4.724	4.724
D5 min. Ø	mm	120	141	141	203	246	246
Base Cross Corners	inch	4.724	5.551	5.551	7.992	9.685	9.685
D6 min. Ø	mm	80	98	98	145	180	180
Optional Gauge	inch	3.150	3.858	3.858	5.709	7.087	7.087
Sq. 1	mm	90	105	105	150	185	185
Base	inch	3.543	4.134	4.134	5.906	7.283	7.283
Sq. 2	mm	72	84	84	125	150	150
Bolt Hole Pattern	inch	2.835	3.307	3.307	4.921	5.906	5.906
M (x4)	mm	M8	M10	M10	M12	M16	M16
G (x4)	BSPP	G-3/8	G-3/8	G-3/8	G-3/8	G-3/8	G-3/8
P Piston Area	cm² inch ²	22.35 3.464	33.18 5.143	33.18 5.143	78.54 12.174	132.73 20.574	132.73 20.574

All dimensions are nominal unless tolerance is stated.

Additional HYDROCAM® System Calculations:

- Calculations are based upon the example as shown on page 4.
- These will assist in understanding optimal working conditions.
- It may be necessary to calculate your total system working pressure and total force required to drive the H-1 pump.

Calculate the Required Total Volume of Oil:

$$VT = \text{Total \# of H-2 units (N)} \times \text{Volume per mm of stroke (from H-2 chart on page 7) (VC)} \times \text{Stroke length of each H-2 unit (SL)}$$

English: $VT = 2 \text{ units} \times .0491 \text{ in}^3 \text{ per mm} \times 25 \text{ mm stroke length} = 2.455 \text{ in}^3$

Metric: $VT = 2 \text{ units} \times .804 \text{ cm}^3 \text{ per mm} \times 25 \text{ mm stroke length} = 40.2 \text{ cm}^3$

For this example, we have chosen an H-1 5 pump, because the maximum volume of this size pump is 3.051 in^3 (50 cm^3) (from H-1 chart on page 9).

Note: *Never use more than 90% of the H-1 units maximum oil volume.*

Calculating the H-1 Piston Rod Travel:

$$\text{Ht 5 (from H-1 chart on pg 9)} + \left(\frac{VT \text{ (from above calculation)}}{V1 \text{ (from H-1 chart on page 9)}} - 0.02 \text{ in} \right) = \text{Piston Rod Travel}$$

English: $.315 \text{ in} + (2.455 \text{ in}^3 \div 3.4636 \text{ in}^3 \text{ per in} - 0.02 \text{ in}) = 1.004 \text{ inch piston rod travel}$

Metric: $8 \text{ mm} + (40.2 \text{ cm}^3 \div 2.235 \text{ cm}^3 \text{ per mm} - 0.50 \text{ mm}) = 25.49 \text{ mm piston rod travel}$

Calculating "Optional" Stroke Gauge Ring Thickness (used for set-up):

$$\text{Ht 3 (from H-1 chart on pg 9)} - \text{Piston Rod Travel (from above calculation)} = \text{Stroke Gauge Ring Thickness}$$

English: $1.22 \text{ in} - 1.004 \text{ in} = 0.216 \text{ inches}$

Metric: $31 \text{ mm} - 25.49 \text{ mm} = 5.51 \text{ mm}$

For this example, we will use the H-1-5 pump (refer to H-1 chart)

Calculating Total Internal Working Pressure:

$$\frac{\text{Maximum System Working Pressure}}{\text{Maximum Rated Force of H-2 Unit (from H-2 chart on pg. 7)}} \times \text{Required Tonnage (from Step \#3 on pg. 4)} = \text{Total Working Pressure}$$

English: $(5,802 \text{ psi} \div 7,050 \text{ lbs.}) \times 6,000 \text{ lbs.} = 4,938 \text{ psi}$

Metric: $(400 \text{ bar} \div 3,198 \text{ daN}) \times 2,765 \text{ daN} = 346 \text{ bar}$

Calculating Total Required Force to Drive H-1:

$$\text{Piston Area of H-1 (from H-1 chart on pg. 9)} \times \text{Total Working Pressure (from above)}$$

English: $3.464 \text{ in}^2 \times 4,938 \text{ psi} = 17,105 \text{ lbs.}$ ($2,000 \text{ lbs.} = 8.6 \text{ U.S. tons}$)

Metric: $22.35 \text{ cm}^2 \times 346 \text{ bar} = 7,733 \text{ daN}$ ($1,000 \text{ N} = 7.7 \text{ metric tons}$)

H1 Pump

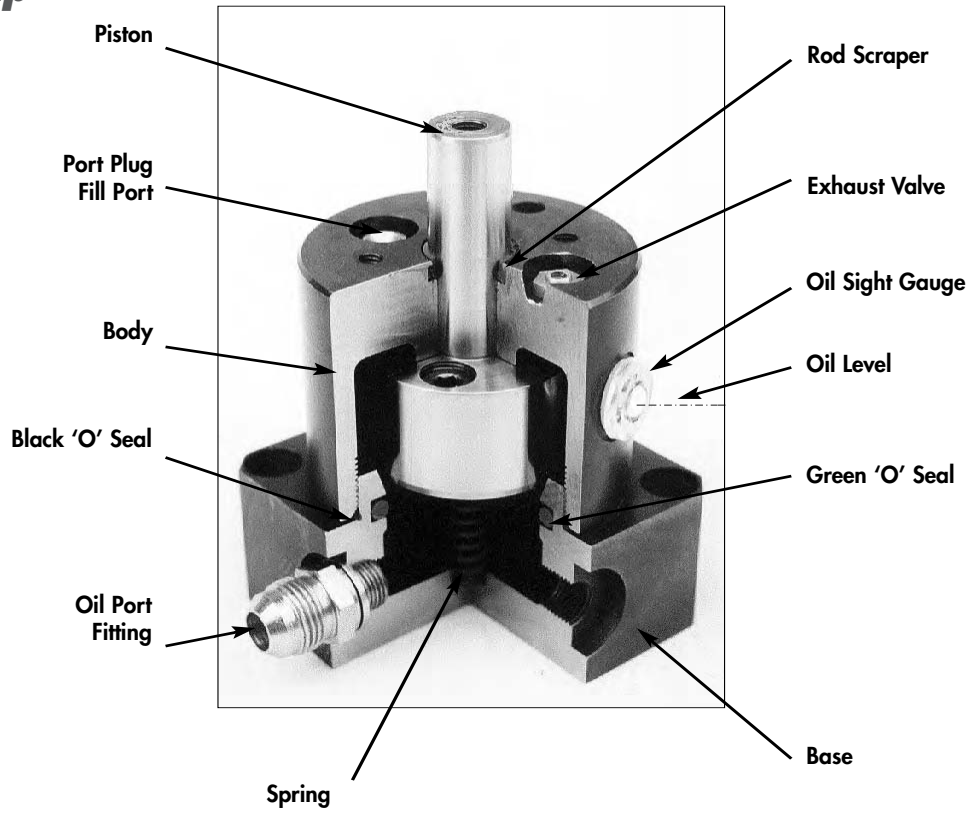

H2 Unit

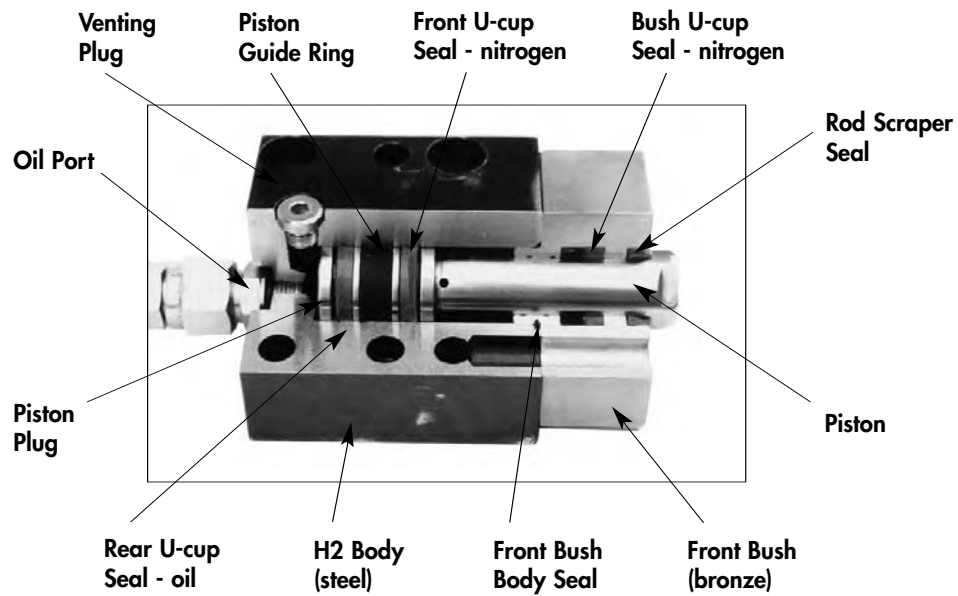

HYDROCAM® Options

Oil Return Option

The oil return option can be an alternative to nitrogen, as a method of returning or retracting the **H-2** unit. This option requires a hose from the **H-2** unit to an external nitrogen/oil accumulator. The typical operating pressure of the forced oil return option is 100 bar (1450 psi). This option may require careful engineering analysis in order to calculate what is best for a customer's application. READY can assist in this evaluation.

User Sequence Option

This option requires careful application engineering to determine feasibility. Engineering fees may apply. User sequence can allow customers to control the timing of their

HYDROCAM® systems. The **H-2** unit can be programmed to extend, dwell, and retract at nearly any point in the stroke. This allows for multiple actions to be performed in a single operation. Contact READY for the latest developments on this exciting **HYDROCAM®** system technology.

Direct Punch Option

This option is used when piercing round holes only. A metric punch of the proper size range can be used. The punch shank size is limited, and is listed on the bottom of the **H-2** selection chart. By removing the standard front plate, the **H-2** piston will accept a customer supplied head type punch. A special locking nut is included with this option. The direct punch option fits compact areas.

Design and Installation Guide

Selecting the Correct H2 Piercing/Forming Unit

1. Determine required cam station tonnage (piercing or forming force, plus total stripping force, plus nitrogen or oil return force). Do not exceed 90% of the **H2** unit's rated force (listed force, less return system force). See page 4.
2. Determine the number of **H2** unit's needed for that tool's applications.
3. Select the **H2** unit's stroke from those offered. A longer stroke could require a larger **H2** unit.
4. Group identical **H2** unit's together (tonnage and stroke). Group identical cam actions together (number, size or shape piercing units, forming, flanging, notching).
5. Determine timing for the extension, dwell and retracting of the **H2** unit's piston rod.
6. Ball Lock Punch applications; Select a 50 mm or longer stroke **H2** unit to provide additional space to remove the punch.

Selecting the Mounting Location for the H2 Piercing/Forming Unit(s).

1. Locate the **H2** unit(s) in any three dimensional orientation, perpendicular to the work.
2. Provide for hose access to the back and right front side of the **H2** unit. Custom porting is not available.
3. Provide a mounting platform that will support three times the total working force of the H2 unit. Locate the **H2** unit against a thrust key.
4. The **H2** unit is designed to provide force, not guidance.
5. The **H2** unit's Piston Rod is designed to extend fully.

*NOTE: **HYDROCAM®**'s unique design eliminates the thrusting force of the ram/slide from the cam station, allowing the use of standard L-GIBS to position and guide the station. Providing a guidance system for a **HYDROCAM®** driven cam station is the responsibility of the customer. Neither, the H2 unit's piston rod, nor its front mounting plate assembly is designed to provide cam station guidance. Contact your representative for application support.*

Design and Installation Guide (Continued)

Selecting the Correct H1 Pump

1. The **H1** Pump is selected by using the information developed while selecting the **H2** unit(s). (See calculation pages in the HYDROCAM® catalogue.) See page 4.
2. Select an **H1** Pump that provides the **H2** unit's volume total within 90% of the **H1** Pump's total volume. Do not exceed 90%. See page 5.
3. The stroke gauge ring can be provided with the **H1** Pump to develop the customer-supplied driver (kiss block) thickness and to ensure precise travel of the **H1** Pump's piston rod.
Note: Machining tolerances may cause the mounting surfaces of the **H1** Pump and/or driver to differ from the drawings. Determine the driver thickness from the finished surfaces, not the drawings.
4. One **H1** Pump may serve up to a maximum of four identical **H2** units.

Selecting the Mounting Location for the H1 Pump

1. The **H1** Pump's piston rod must be up and perpendicular to the ram/slide. Do not mount the **H1** Pump in an inclined press or an inclined special machine.
2. Locate the **H1** Pump's oil supply ports above the **H2** unit's vent port elevation. See page 8.
3. Locate the **H1** Pump anywhere in the die, under the ram/slide, that provides balance and simple hose access to the **H2** unit(s). Avoid areas using spray lubrication.
4. Locate the **H1** Pump within 2 meters (six feet) of the **H2** unit(s).
5. Rotate the **H1** Pump prior to mounting to ensure access and viewing of the Pump's sight gauge.

NOTE: As with any air, hydraulic or nitrogen cylinder, neither the **H1** Pump nor the **H2** unit is designed to withstand side-thrust forces. Properly guiding the tool and cam station will minimize wear to the cylinders and increase seal life.

Special Timing of the H2 Unit's Piston Rod Extension, Dwell and Retraction.

Request the help of your representative to select a:

1. Larger **H1** Pump to begin cam extension later in the stroke.
2. Nitrogen cushion to begin cam extension earlier in the stroke.
3. Sequenced Solenoid Technology (SST) for special timing requirements.
4. Hydraulic or air cylinder, pressure system for special machine applications.

Design Procedure - H1 Pump's Piston Rod Driver

The **H1** Pump's piston rod travel is critical to the successful operation of the **HYDROCAM**® system.

1. Machine smooth and parallel, the tool's mounting surfaces for the **H1** Pump (lower) and the customer-supplied driver (upper). The diameter of the driver's contact surface is a minimum of twice the diameter of the **H1** Pump's piston rod. This contact surface must be smooth and parallel with no mounted holes. Use a 45 Rockwell C plate for the driver.
- 2a. If the **H1** Pump's, stroke gauge ring is available, mount and use it to develop the travel of the **H1** Pump's piston rod. The measurement from the base of the **H1** Pump, to the top of the mounted stroke gauge ring determines the die-closed position of the customer-supplied driver's contact surface. Use this measurement to calculate the length of the customer-supplier driver. We recommend that the stroke gauge ring be removed and stored on the tool prior to stroking the **H1** Pump.

OR ...

- 2b. Use the formula (Calculating the **H1** Piston Rod Travel) from the **HYDROCAM**® catalogue to determine the length of the **H1** Pump's piston rod travel. See page 5 for the **H1** selection and travel of piston. The measured height from the base of the **H1** Pump, to the top of the piston rod extended, less the calculated piston rod travel, locates the die closed position of the contact surface of the customer-supplied driver. Use this measurement to calculate the length of the driver.

Nitrogen Return System

1. Always use a control panel.
2. For each **H1** Pump, use at least one control panel that connects that **H1**'s associated **H2** units.
3. Use O-ring style hose fittings.

Note: We understand that a few applications will exceed this guide. Contact your representative for application support.

Design and Installation Guide (Continued)

Connecting the H1 Pump, H2 Piercing/Forming Unit(s) and Nitrogen Return Control Panel. See page 8.

1. Minimize the number of fittings in the hose system.
2. Do not use a hose system that involves a fitting - to fitting - to fitting series of connections.
3. Hose each identical **H2** unit to a **H1** Pump with its own hose. Do not hose in series. Provide simple access for hose routing. Use only approved hose and fittings.
4. Provide additional hose length to ensure appropriate radius and safe routing. Avoid high spots in the oil hose route that will trap and create air pockets.
5. Maximum hose length is 2 meters (six feet). Do not substitute the supplied hydraulic hose with a smaller or lighter duty hose.
6. Rotating the **H1** Pump 45° may simplify hose routing.
7. Avoid turning fittings. If a hose turn requires a turning fitting, select a 45° fitting as a first choice and a 90° fitting second. Use only BSPP-style fittings.

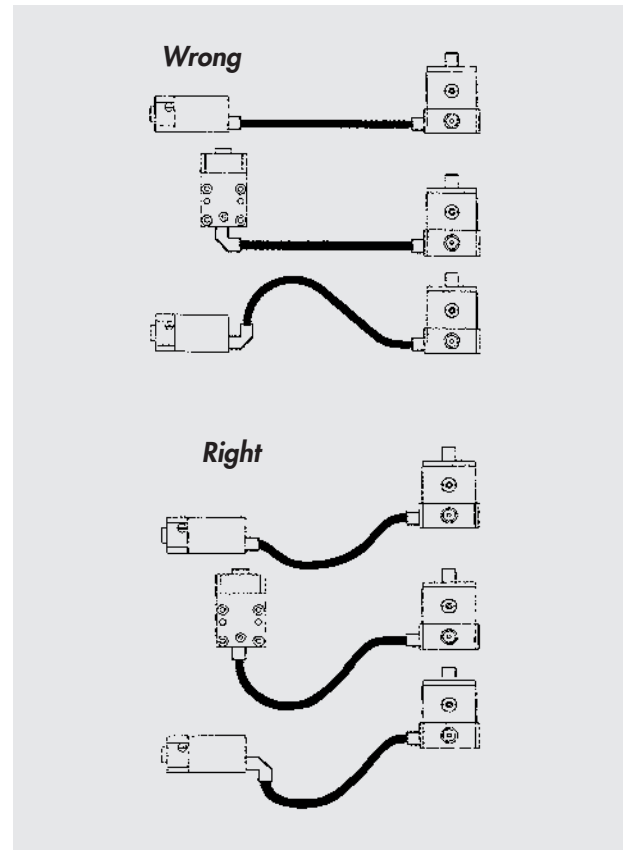

Required position of H1 as compared to H2 See above for proper positioning of the H1 Pump.

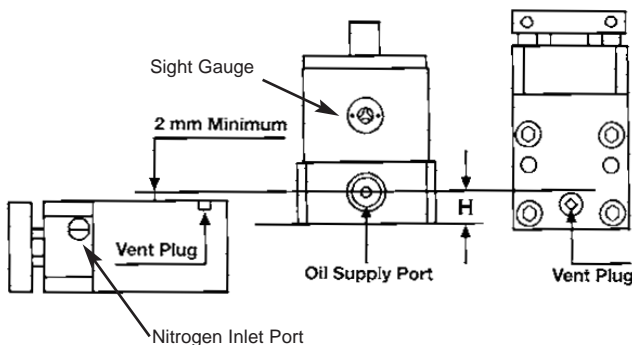

NOTE: We understand that a few applications will exceed this guide. Contact your representative for application support.

Model	H dimension
HYDROCAM H1-5	21 mm (0.83 in)
HYDROCAM H1-8	25 mm (0.98 in)
HYDROCAM H1-13	25 mm (0.98 in)
HYDROCAM H1-20	25 mm (0.98 in)
HYDROCAM H1-40	30 mm (1.18 in)
HYDROCAM H1-66	40 mm (1.57 in)

- Standard **HYDROCAM®** systems operate using a simple hydraulic driven extension with a nitrogen return and require no special conditions or procedures to operate them.
- **DO NOT SUBSTITUTE ANY COMPONENT IN THIS SYSTEM! IMPROPER SUBSTITUTIONS MAY RESULT IN PERFORMANCE PROBLEMS AND/OR SAFETY HAZARDS.**
- **USE ONLY A PREMIUM GRADE HYDRAULIC OIL.**
- As with any air, hydraulic or nitrogen cylinder, neither the **H1** Pump nor the **H2** unit is designed to withstand side-thrust forces. Properly guiding the tool and cam station will limit damage to the cylinders and increase seal life.
- **THE MOST COMMON HYDROCAM® OPERATING PROBLEM IS AIR CAUGHT IN THE HOSE SYSTEM. ENSURE THAT YOU HAVE PROPERLY LOCATED THE H1 PUMP, AVOIDED HIGH SPOTS IN THE HOSE SYSTEM AND BLED THE SYSTEM OF AIR.**
- Complete engineering assistance, seminars and service support are available should a need arise for any of our full line of metal forming products. Contact your representative for details.

Design and Installation Guide (Continued)

H1 Pump

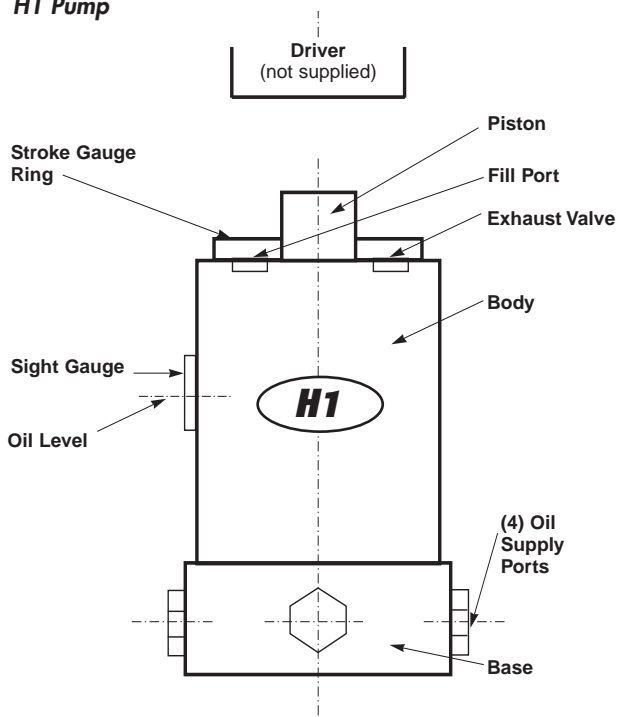

PROVIDING A GUIDANCE SYSTEM FOR THE PIERCING OR FORMING STATION IS THE RESPONSIBILITY OF THE CUSTOMER. NEITHER THE H2 PIERCING/FORMING UNIT'S PISTON ROD NOR ITS FRONT MOUNTING PLATE ASSEMBLY IS DESIGNED TO PROVIDE CAM GUIDANCE.

H2 Unit

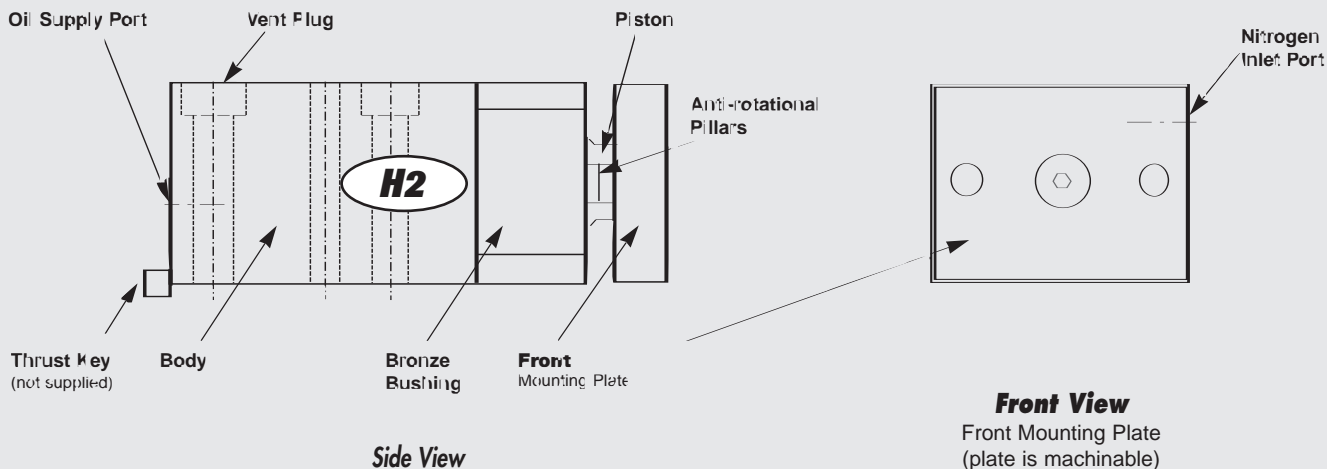

HYDROCAM® Accessories

Control Panel - MODEL RT-2175-CP

READY Technology recommends the use of a control panel with all nitrogen return systems for each **H-1** pump. Use at least one control panel per system. This NAAMS control panel is designed for remote mounting and is used to monitor or adjust nitrogen pressure in the **H-2** unit. The panel is also equipped with a rupture plug for added safety. Each control panel includes the necessary hose and straight connectors to connect one **H-2** unit. O-ring face connectors can also be supplied upon request.

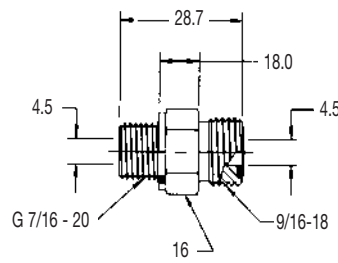

O-ring Male Straight Connector
READY Part # RT4F5OLO-S

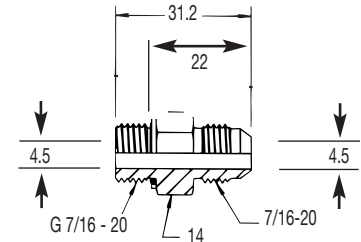

G-1/8 Male Straight Connector
READY Part # RT4F5OX-S

Bottom View

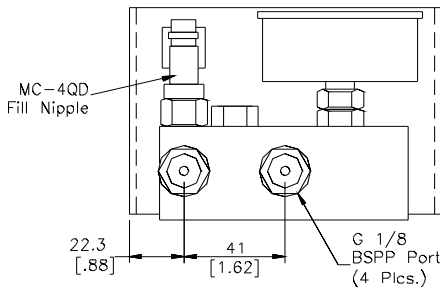

Front View

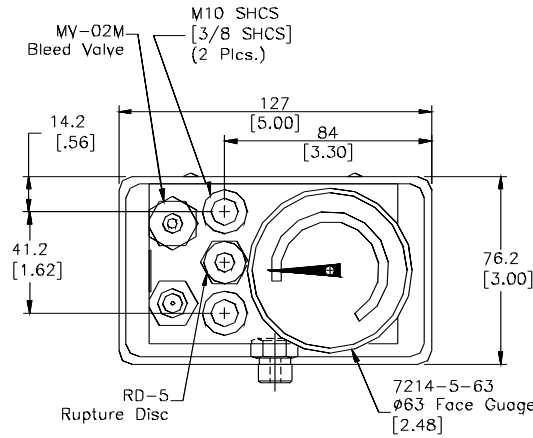

Side View

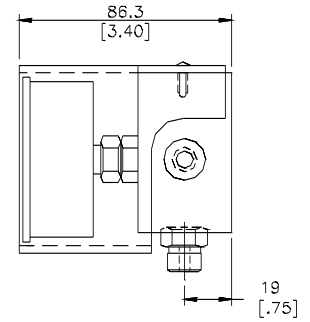

Suggested drilling pattern for customer to mount the NAAMS standard control panel.

Junction Block

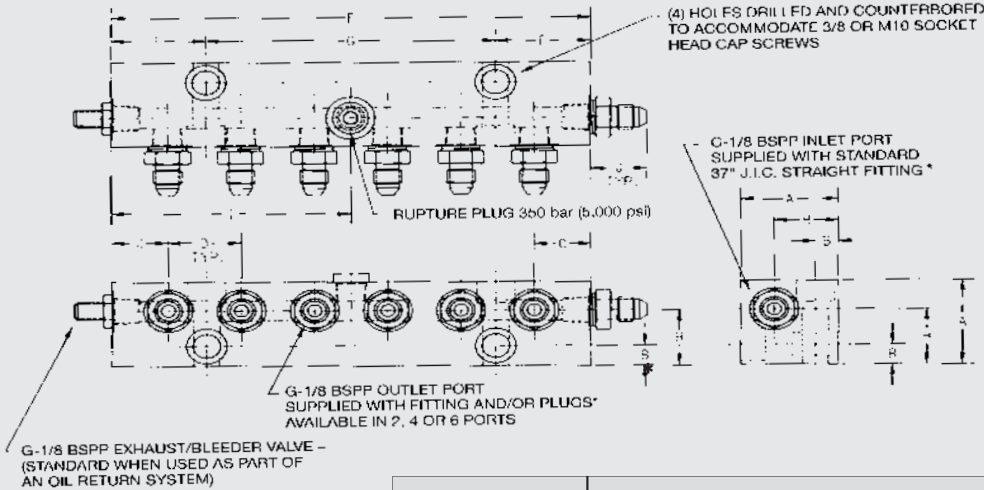

HR-6 model shown above

* O-ring face connectors can also be supplied upon request.

Model	A	B	C	D	E	F	G	H	I	J
HR-2	38 1.50	9 0.35	22 0.87	29 1.14	73 2.87	9 0.35	55 2.17	25 0.98	36.5 1.44	22 0.87
HR-4	38 1.50	9 0.35	22 0.87	29 1.14	131 5.16	37 1.46	57 2.24	25 0.98	65.5 2.58	22 0.87
HR-6	38 1.50	9 0.35	22 0.87	29 1.14	187 7.36	37 1.46	114 4.49	25 0.98	93.5 3.68	22 0.87

For Self-Contained Systems

To fill or recharge nitrogen gas quickly and easily, order the quick disconnects:

Part #RT-QDM-6251-A

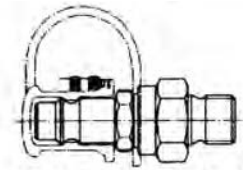

Part #RT-QDM-6-A (H2-2 model only)

Standard System Fittings - Nitrogen Gas

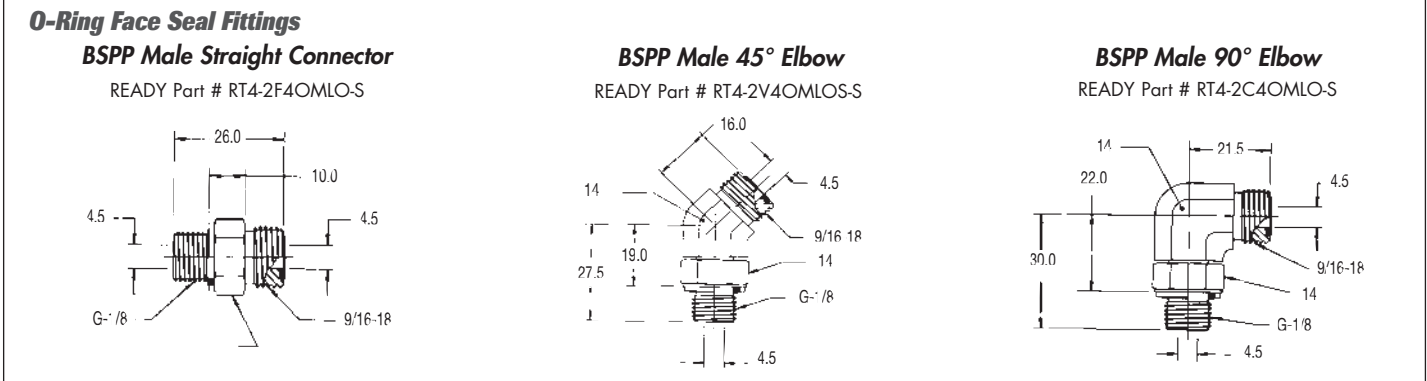
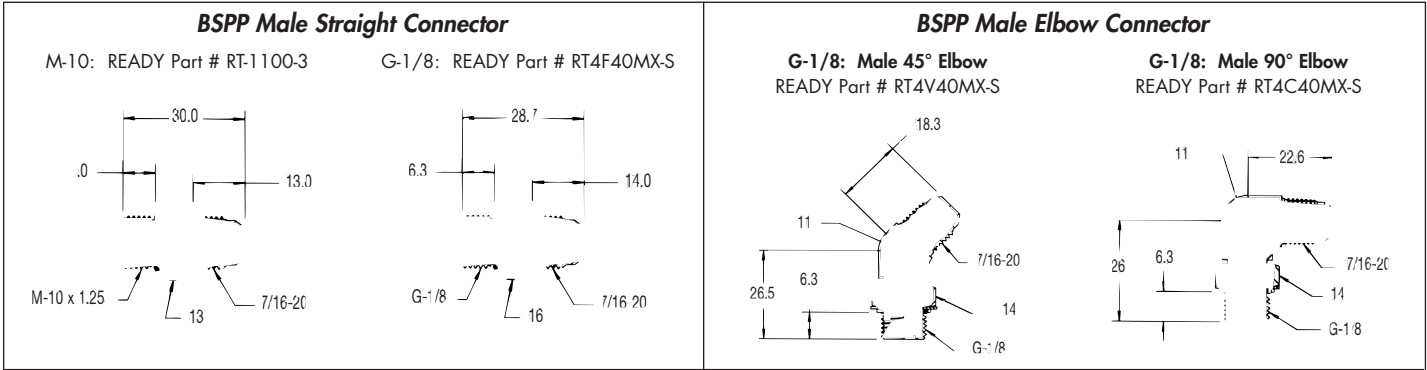

Control Panel Hose

Important: The hose length should be a minimum of 5% longer than the actual measured length. The additional length provides for the contraction of the hose length when pressurized.

Note: The inlet valve must be removed prior to hosing.

O-Ring Face Seal Hose

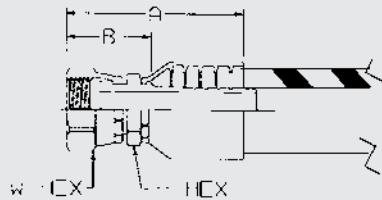

Part # RT52041JC55-(*)
(* = specify required hose length)

37° JIC Hose

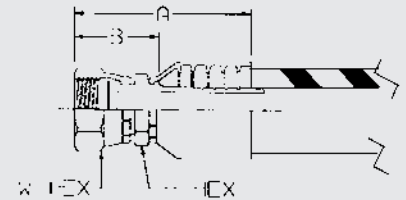

Part # RT520410655-(*)
(* = specify required hose length)

Part No.		Hose I.D.	Hose O.D.	Max. Operating Pressure MPa / psi	Burst Pressure MPa / psi	Min Bend Radius	Thread Size	A	H Hex	W Hex	B
RT520410655-(*)	mm inch	6.4 0.25	13 0.51	34.5 5000	138 20,000	51 2	- 7/16-20	64 2.5	16 5/8	16 5/8	35 1.38
RT52041JC55-(*)	mm inch	6.4 0.25	13 0.51	34.5 5000	138 20,000	51 2	- 9/16-18	50 1.97	18 11/16	16 5/8	27 1.06

Service Gauge Assembly

This assembly is multi-functional. Use it to fill, empty, adjust, or take an accurate reading of pressure in the **H-2** unit. Installation of this device will result in a nominal loss of pressure.

READY Part # RTUAL-04.0QDM

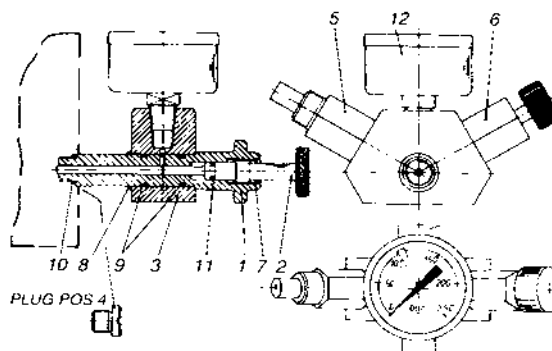

- 1 Casing
- 2 Pressure Adjusting Screw
- 3 Body
- 4 Threaded Plug
- 5 Inlet Valve
- 6 Outlet Valve
- 7 Retaining Ring
- 8 Circlips
- 9 O-ring
- 10 O-ring
- 11 O-ring
- 12 Gauge

Standard System Fittings - Hydraulic

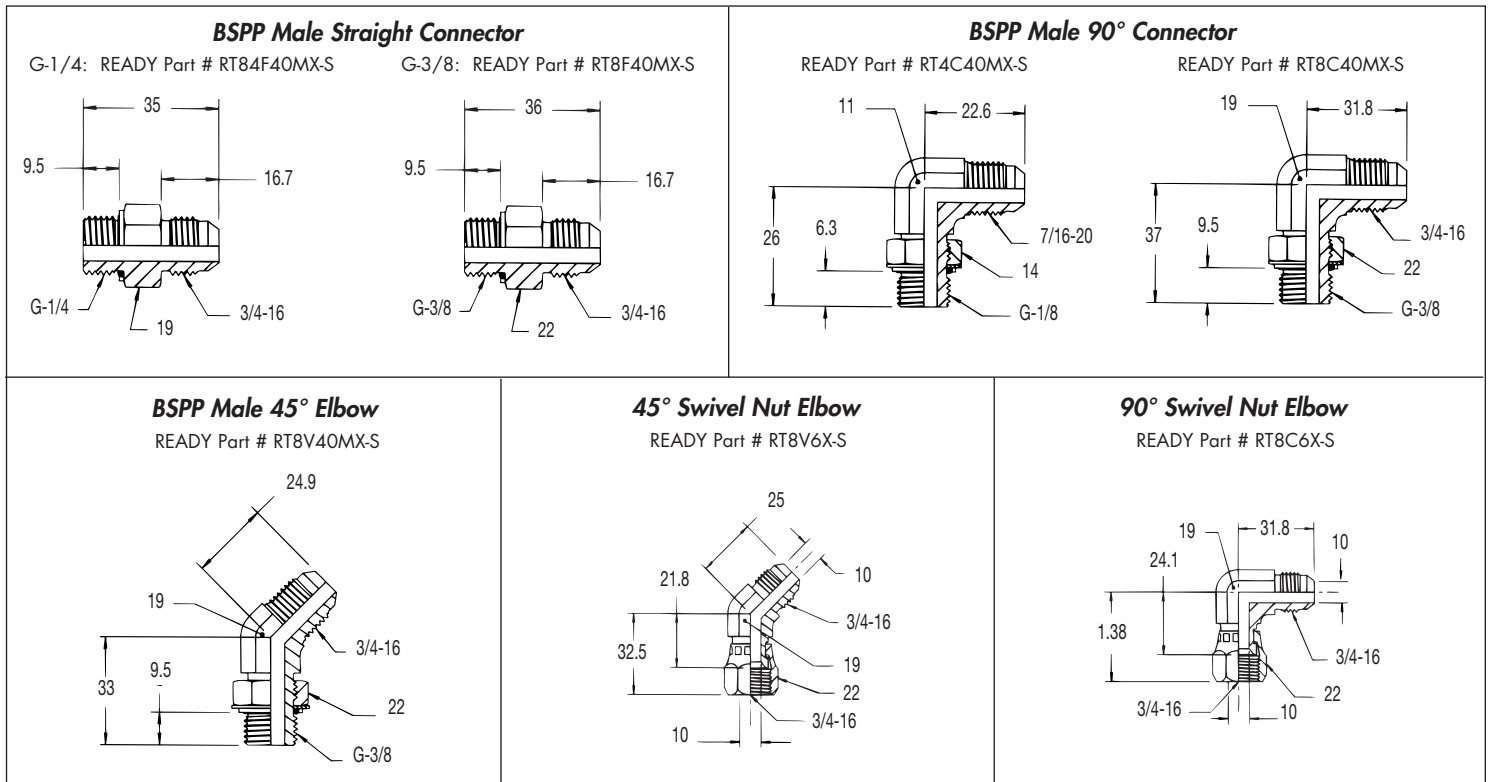

Flexible High Pressure Hoses and Connectors

- Minimize the number of fittings in the hose system.
- Do not use a hose system that involves a fitting – to fitting – to fitting series of connections.
- Hose each **H-2** unit to an **H-1** pump with its own hose. Do not hose in series. Provide simple access for hose routing.
- Provide additional hose length to ensure appropriate radius and safe routing. Avoid high spots in the oil hose route that will trap and create air pockets.

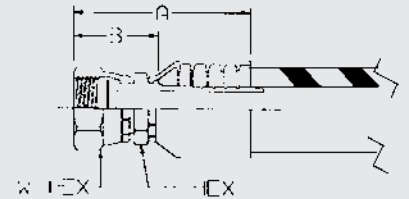

Hose to Connect H-1 to H-2

Part No.	Hose I.D.	Hose O.D.	Max. Operating Pressure MPa / psi	Burst Pressure MPa / psi	Min Bend Radius	Thread Size	A	H Hex	W Hex	B	
RT701810670-(*)	mm inch	12 0.50	25 0.97	41.5 6000	166 24,000	230 9	- 3/4-16	66 2.60	21 13/16	22 7/8	36 1.42

*Standard hose lengths are 3' or 6'. Specify custom lengths if needed. All hose and connectors are available individually, as assemblies, or in bulk upon request.

READY Hand Pump of 1.8 Litre Capacity (250 bar maximum output)
Reduce **HYDROCAM®** Set-up Time By Using This Hand Pump. This Oil Hand Pump Can Be Used for Three Different Purposes:

1. Directly connected to the **H-2** unit, it moves the piston to allow the toolmaker to align punch and die within the tool.
2. Filling the **H-1** pump when the system is in the tool.
3. Filling the oil/nitrogen accumulator if using oil return option.



Extending **H-2** piston rod



Filling oil drive system



Filling oil return system

Hand pump with hose and adapter fittings



Call Us Today...

- *for service and technical support*
- *to incorporate Hydrocam in your designs or engineering changes*

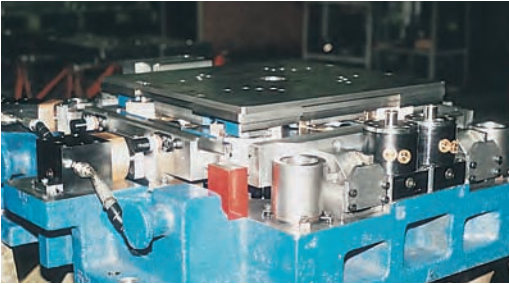

Transfer die application, multiple units

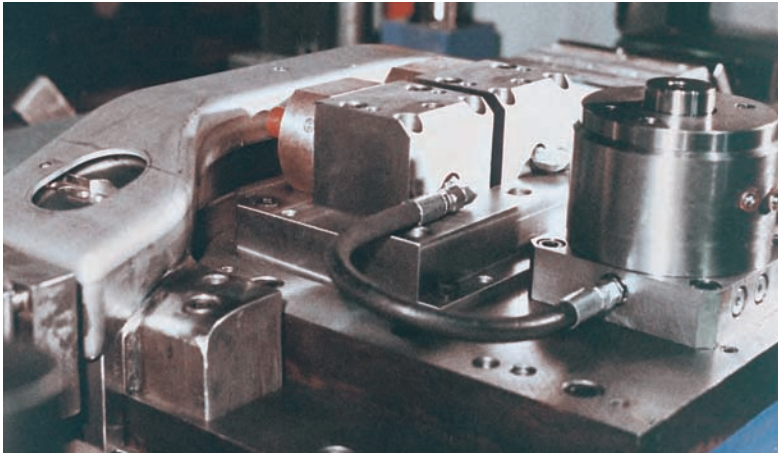

Pierces two holes in .227" thick steel

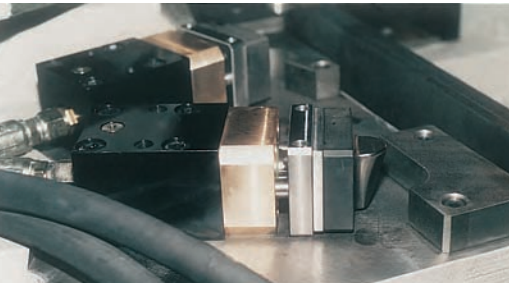

Special machine forms corner shapes

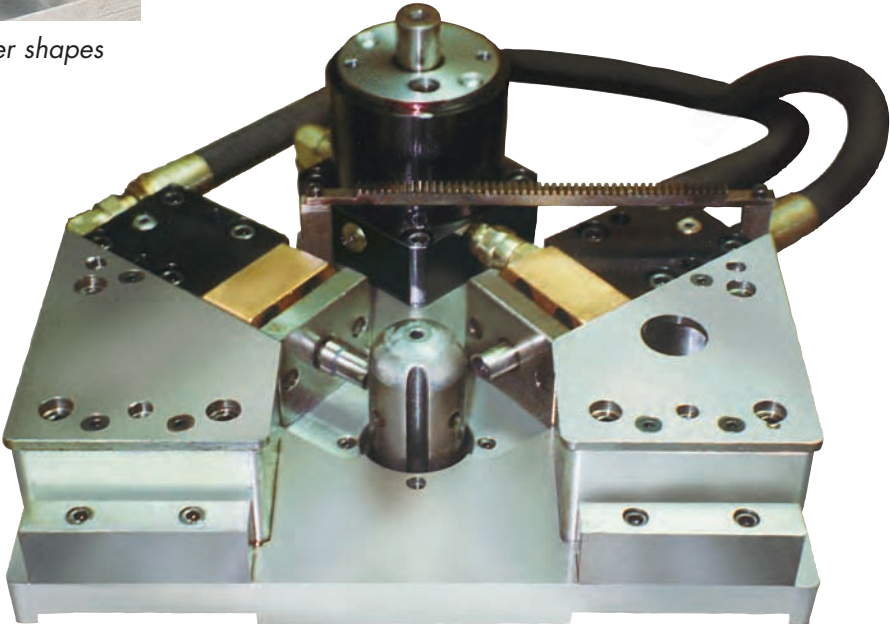

Worksheet for READY HYDROCAM®

For Fast Quotes . . . Copy This and Fax READY the Details.

Name: _____ Title: _____
 Company: _____
 Address: _____
 City: _____ State: _____ Zip _____
 Telephone: _____ Fax: _____
 Project, Part No.: _____

READY No: _____

Date: _____

Selection Criteria

Part Material: _____
 Part Thickness: _____
 Tensile Strength: _____ daN(Psi)
 Stripping Force: _____
 RAM Strokes/Minute: _____
 RAM travel of press: _____ mm(inch)
 CAM Stroke Length: _____

Proximity H1 Pump To Cam Unit

- The H1 pump will be connected by:
 Hose Length _____
- Special fittings needed _____

Are You Forming? Describe Form:

Please Note Special Concerns/Timing:

Are You Piercing Holes?

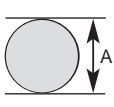
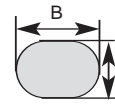
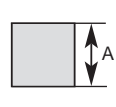
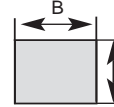
				
	A mm (inch)	A mm (inch) B mm (inch)	A mm (inch)	A mm (inch) B mm (inch)
hole #1				
hole #2				
hole #3				
hole #4				

Punch/matrix clearance per side: _____ (% of Part Thickness)

What Type of Stripper?

- Method used to strip _____
- Is this used for all holes _____
- Comments _____

What CAM Stroke Length Needed?

- H-2 #1 _____ mm (inch) to be piercing hole #1
- H-2 #2 _____ mm (inch) to be piercing hole #2
- H-2 #3 _____ mm (inch) to be piercing hole #3
- H-2 #4 _____ mm (inch) to be piercing hole #4

Do You Want Standard Front Plate: _____
 Or Direct Punch Mount Option: _____

Proximity Nitrogen Return Control Panel To CAM Unit

- The control panel will be connected by:
- Hose length: _____
 - Special fittings needed: _____

READY TECHNOLOGY, INC.

333 Progress Rd. • Dayton, OH 45449
 937-866-7200 • 800-543-4355 • Fax 937-866-7226
 email: sales@readytechnology.com