

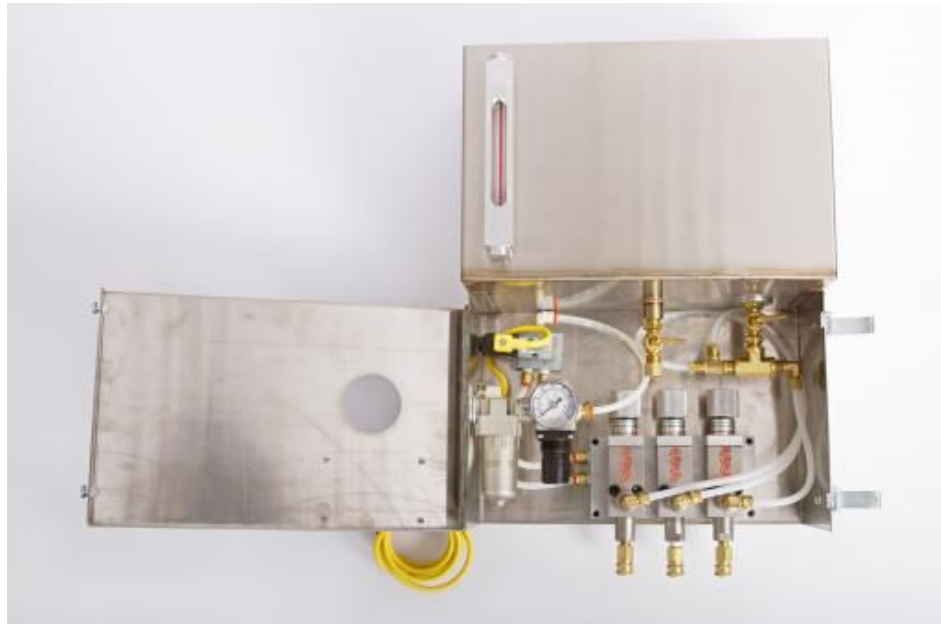

(248) 545-4441  
info@jetsetspray.com  
http://jetsetspray.com

# JET-SET® JP-3E

**2 GALLON 3 PUMP 1 SOLENOID - ELECTRICALLY ACTIVATED**



The JET-SET® Jet-Pack module provides you with a complete automatic airless spray system. These systems come with up to four 7100-pumps and can be activated together or individually. For individual use, the 7100-pumps can come on its own manifold with its own electrically activated solenoid giving you the option of when and where to fire each pump. The JP-3E comes with standard 110v unless specified otherwise.

All the Jet-Pack systems come complete with our 7100-pump that offers high life cycles with very low maintenance. Utilizing stainless steel components and Viton seals, our 7100 pump will provide millions of trouble free cycles.

Jet-Pack modules are all stainless steel with our standard 2.5 gallon tanks. The Jet-Pack system utilizes a reusable filter, air regulators and stainless steel pumps with quick disconnect to each nozzle. Jet-Pack systems can also be supplied with 5 or 21 gallon reservoirs. Volume output is from 0 to 1 cc of fluid. Jet-Pack pumps are mounted on manifolds for ease of pump change-over.



Established 1963  
jetsetspray.com

# JET-SET® JP-3E

2 GALLON 3 PUMP 1 SOLENOID - ELECTRICALLY ACTIVATED

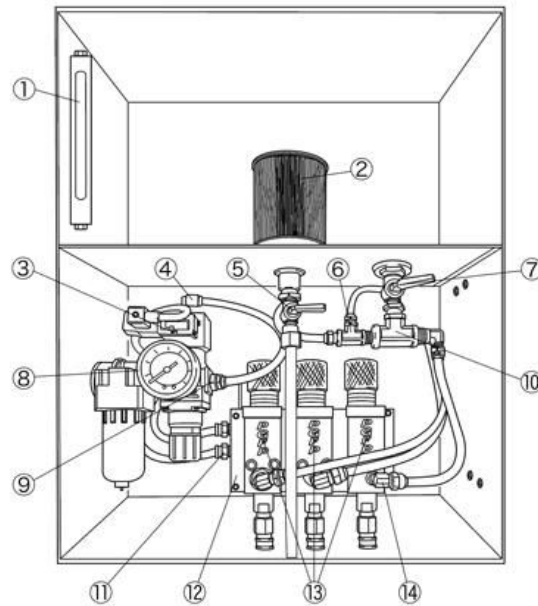

## INDIVIDUAL PART NUMBERS:

- |  |   |
|--|---|
| 1) 525: Sight Glass with Fittings      | 8) 1501: Air Regulator Assembly         |
| 2) 620: Stainless Steel Filter         | 9) 813-P: 1/4" Tube x 1/4 NPT Push In   |
| 3) 1400-JP: JP Solenoid                | 10) 505-E: 1/4 NPT Tee                  |
| 4) 834-P: 1/8"NPT x 1/4" Push-In Elbow | 11) 820-P: 1/4" Tube x 1/8" NPT Push In |
| 5) 505-A: Brass Stopcock               | 12) 7122-3: 3 Pump Manifold             |
| 6) 860: 1/4"x1/4" Run Tee              | 13) 7100: 7100 Stainless Steel Pump     |
| 7) 505-A: Brass Shut Off               | 14) 834: Male Elbow                     |



(248) 545-4441  
info@jetsetspray.com  
<http://jetsetspray.com>

# JET-SET® JP-3E

**2 GALLON 3 PUMP 1 SOLENOID - ELECTRICALLY ACTIVATED**

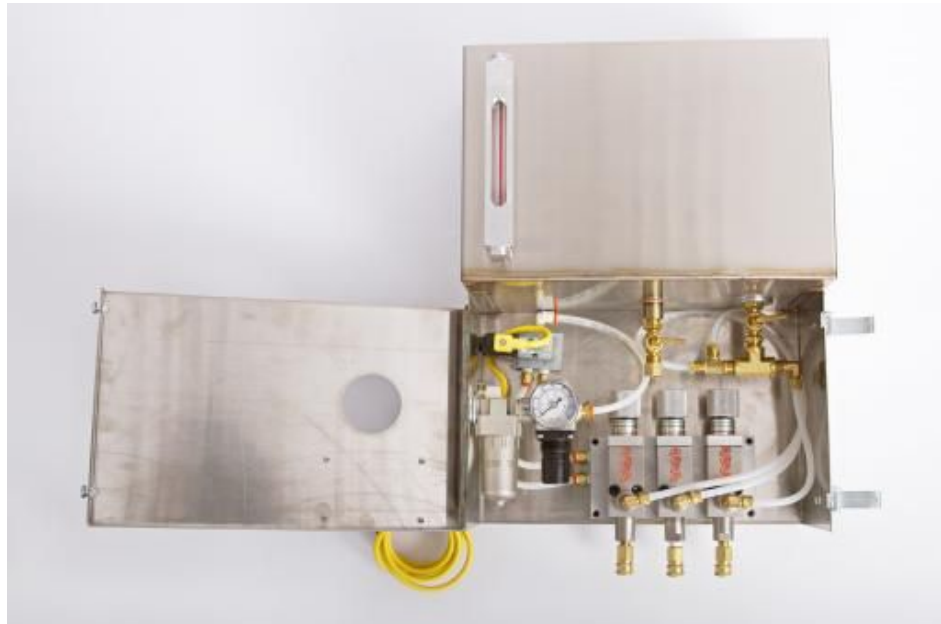

The JET-SET® Jet-Pack module provides you with a complete automatic airless spray system. These systems come with up to four 7100-pumps and can be activated together or individually. For individual use, the 7100-pumps can come on its own manifold with its own electrically activated solenoid giving you the option of when and where to fire each pump. The JP-3E comes with standard 110v unless specified otherwise.

All the Jet-Pack systems come complete with our 7100-pump that offers high life cycles with very low maintenance. Utilizing stainless steel components and Viton seals, our 7100 pump will provide millions of trouble free cycles.

Jet-Pack modules are all stainless steel with our standard 2.5 gallon tanks. The Jet-Pack system utilizes a reusable filter, air regulators and stainless steel pumps with quick disconnect to each nozzle. Jet-Pack systems can also be supplied with 5 or 21 gallon reservoirs. Volume output is from 0 to 1 cc of fluid. Jet-Pack pumps are mounted on manifolds for ease of pump change-over.



Established 1963  
[jetsetspray.com](http://jetsetspray.com)



(248) 545-4441  
info@jetsetspray.com  
http://jetsetspray.com

# JET-SET® JP-3E

2 GALLON 3 PUMP 1 SOLENOID - ELECTRICALLY ACTIVATED

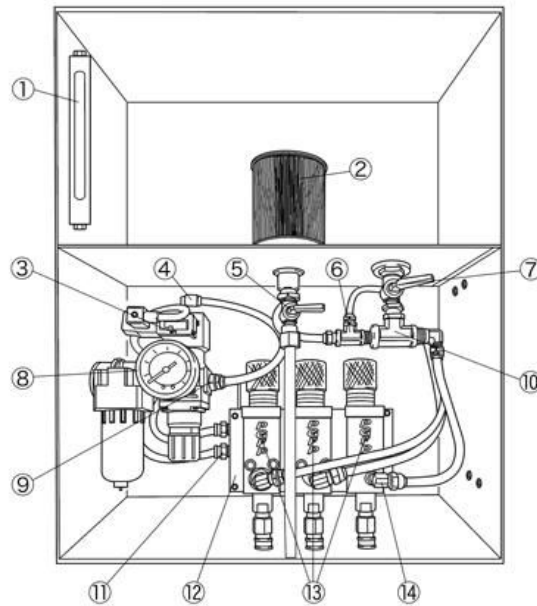

## INDIVIDUAL PART NUMBERS:

- |  |   |
|--|---|
| 1) 525: Sight Glass with Fittings      | 8) 1501: Air Regulator Assembly         |
| 2) 620: Stainless Steel Filter         | 9) 813-P: 1/4" Tube x 1/4" NPT Push In  |
| 3) 1400-JP: JP Solenoid                | 10) 505-E: 1/4 NPT Tee                  |
| 4) 834-P: 1/8"NPT x 1/4" Push-In Elbow | 11) 820-P: 1/4" Tube x 1/8" NPT Push In |
| 5) 505-A: Brass Stopcock               | 12) 7122-3: 3 Pump Manifold             |
| 6) 860: 1/4"x1/4" Run Tee              | 13) 7100: 7100 Stainless Steel Pump     |
| 7) 505-A: Brass Shut Off               | 14) 834: Male Elbow                     |



Established 1963  
jetsetspray.com



## Jet Pack Mounting Instructions

### INSTALLATION

1. Using the template provided, select a location that will be convenient for filling the tank and making setup changes.
2. Drill and tap two holes for bolts to support the module. The template will provide you with the exact location of the holes.
3. Now hang the module and connect shop air to the ¼" F.P.T. brass fitting located on the left side of the module.
- 4a. Place the air switch where the trigger rod\* can best be activated by mechanical movement. The switch may be adjusted to fire in either direction or in both directions. To change direction: See attached "714N Air Switch Installation Data."
- 4b. \*If installing an electrically activated module, a four way solenoid has been provided to activate the pump. Simply complete the circuit from the four way solenoid to the switch of your choice. See attached "1400N Solenoid Valve Instructions" or "1400 SMC Valve Instructions"
5. Keeping all the nozzle leads the same approximate length, plug the quick disconnect hose connectors into the bottom of the Module. Keeping the nozzle leads the same length assures even distribution of fluid to each nozzle. Position nozzles where needed.
6. When using the standard high pressure nylon tubing provided, we recommend spraying light viscosity fluids. Copper tubing conversion kit is available for spraying heavy viscosity fluids.
7. With the large knurled knob on the control panel turned all the way out, hand activate the air switch until all air is out of the system. See attached "How to Bleed Air From The Manifold of #9100 Pump" \*If installing an electrically activated module, a four way solenoid has been provided to activate the pump. Simply complete the circuit from the four way solenoid to the switch of your choice. See attached "1400N Solenoid Valve Instructions" or "1400 SMC Valve Instructions"







## Jet Pack Mounting Instructions

### FINAL ADJUSTMENT

1. To adjust the volume of liquid being sprayed, turn the large knurled knob on the control panel clockwise to decrease, and counterclockwise to increase. With the air regulator set at high pressures it may be necessary to hand activate the air switch to relieve air pressure and allow the knob to move freely.
2. To adjust the air pressure on the unit, turn the adjustment knob which is under the panel and just below the gauge. This adjustment will regulate the velocity of the spray. The higher the air pressure, the higher the velocity of spray. We suggest lowering the air pressure until the best spray pattern has been obtained.
3. Position the spray nozzles for the coverage desired. The distance away from the surface will determine the area of coverage. If longer nozzle leads are required or nozzle placement is a question CALL YOUR JETSET® DISTRIBUTOR or visit us online at <http://www.JetSetSpray.com> . JETSET® distributors carry a complete line of interchangeable spray tips for changing spray patterns, nozzle holders and the required high pressure nylon tubing.





# JET-SET® GUIDES

## System Troubleshooting

(248) 545-4441  
 info@jetsetspray.com  
 http://jetsetspray.com

### System Troubleshooting

Problem	Possible Cause	Possible Solution
Entire system will not operate	1. Solenoid Wiring	1. Check for correct wire hookup
		1A. Check for proper placement of sensor or micro switch
	2. Loss of Air Pressure	2. Check air regulator for adequate pressure adjust for operation at 10PSI-130PSI.

### Pump Troubleshooting

Problem	Possible Cause	Possible Solution
<b>Pump Will Not Operate</b>	1. Pump will not draw fluid in feedline.	1. Check tank fluid level, be sure the fluid stopcock is in open position.
		1a. Be sure the filter surface is clean.
	2. Pump may have an air lock in the fluid discharge area.	2. Follow pump priming procedure. Refer to "Pump Priming Instruction Sheet".
	3. Oil in the feedline rises and falls with each cycle of operation.	3. Inspect Inlet SS Seat for proper placement of spring and SS Ball. Inspect for foreign matter lodged between seat and ball that may prevent proper seating action.
	4. Fluid in the spray line rises and falls with each cycle of operation.	4. Inspect Outlet SS Seat for proper placement of spring and SS Ball. Inspect for foreign matter lodged between seat and ball that may prevent proper seating action.
	5. Pump passes air into the nozzle line while in idle position or during operation.	5. Check pump position "O" rings for wear. Replace seals if needed.
		5a. Be sure fluid connectors supplying the pump are tight.



Established 1963  
 jetsetspray.com



# JET-SET® GUIDES

## System Troubleshooting

(248) 545-4441  
info@jetsetspray.com  
http://jetsetspray.com

### Spray Troubleshooting

Problem	Possible Cause	Possible Solution
Poor Spray Pattern	1. Low air regulator pressure.	1. Increase regulator pressure to obtain optimum pattern.
	2. Contaminated nozzle ballcheck and strainer.	2. Clean or replace as necessary. Make sure all nozzles have ballcheck for proper spray checking action.
	3. Flex spray lines too long.	3. Keep to a minimum all nozzle leads. When using a lubricant with higher viscosity, replace nylon leads with rigid tubing for best spraying results.
	4. Air is trapped in spray lines or in a pump outlet manifold.	4. Bleed all nozzle leads of air. Refer to "Pump Priming Instruction Sheet" to clear air in the pump.

**TO ASSURE CONTINUED TROUBLE FREE OPERATION OF YOUR JETSET® SYSTEM, A DAILY CHECK OF THE FOLLOWING IS RECOMMENDED.**

1. Drain air filter regulator bowl of moisture buildup.
2. Check spray nozzles for proper placement and spray quality.
3. Check for contaminants in holding tank. Clean filter element as needed.
4. Check for proper lubricant level and refill as needed to assure continual operation



Established 1963  
jetsetspray.com





**JET-SET® GUIDES**

(248) 545-4441  
info@jetsetspray.com  
http://jetsetspray.com

**7100 Pump**

# **JET-SET® 7100-PUMP**

## **JET PACK 7100 PUMP**



**JET-SET® #7100 Jet Pack Pump offers the ability to use an individual pump or pumps for each lubrication point. Designed for low volume output, Jet Pack Pumps are ideal for those small jobs that require a precise amount of lubricant. Manifold mounted and constructed of all stainless steel components, Jet Pack Pumps offer long life cycle expectancy at cycle rates of 600 per minute. Jet-Set #7100 Pump is compatible with a range of metalworking fluids. Jet-Set #7100 Jet Pack Pump is self-priming and can be adjusted to deliver from 0 to 1 cc of fluid per cycle.**



Established 1963  
jetsetspray.com



# JET-SET® 7100-SK

## SEAL KIT FOR 7100 PUMP

### New Style Pump

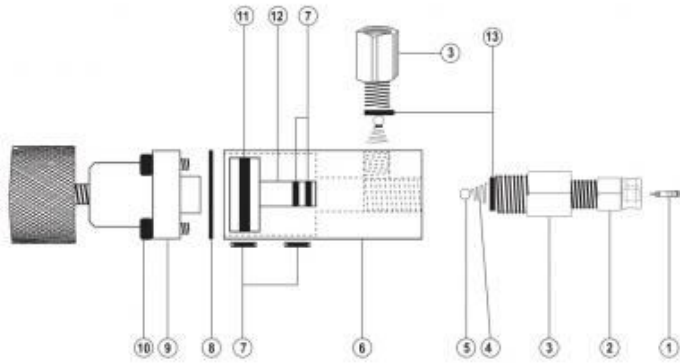

- |                                    |                             |
|------------------------------------|-----------------------------|
| 1. 802V VALVE CORE                 | 8. 7113 GASKET              |
| 2. 802 MIDGET SOCKET               | 9. 7114 A END CAP ASSEMBLY  |
| 3. 7104 SEAT AND SPRING HOLDER(2)  | 10. 7121 MOUNTING SCREW (4) |
| 4. 9103 STAINLESS STEEL SPRING (2) | 11. 7112 VITON O-RING       |
| 5. 9102 STAINLESS STEEL BALL (2)   | 12. 7111 STAINLESS STEEL    |
| PISTON                             |                             |
| 6. 7101 S.S. PUMP BODY GASKET      | 13. 9118 VITON O-RINGS (2)  |
| 7. 7108 VITON O-RINGS (4)          |                             |





# JET-SET® 7100-SK

## SEAL KIT FOR 7100 PUMP OLD STYLE

### Old Style Pump

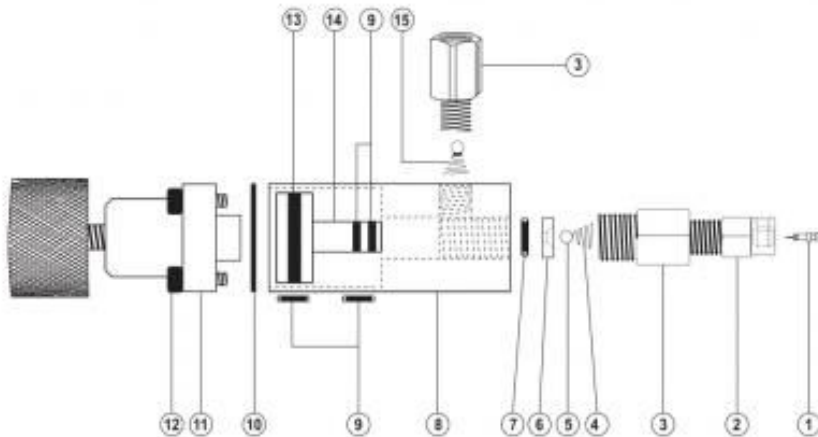

- |                                   |            |                        |
|-----------------------------------|------------|------------------------|
| 1. 802V VALVE CORE                | 8. 7101    | S.S. PUMP BODY GASKET  |
| 2. 802 MIDGET SOCKET              | 9. 7108    | VITON O-RINGS (4)      |
| 3. 7104 SEAT AND SPRING HOLDER(2) | 10. 7113   | GASKET                 |
| 4. 9103 S.S. SPRING (2)           | 11. 7114 A | END CAP ASSEMBLY       |
| 5. 9102 S.S. BALL (2)             | 12. 7121   | MOUNTING SCREW (4)     |
| 6. 7106 S.S. SEAT WASHER          | 13. 7112   | VITON O-RING           |
| 7. 7105 VITON O-RING              | 14. 7111   | STAINLESS STEEL PISTON |





**JET-SET® GUIDES**

(248) 545-4441  
info@jetsetspray.com  
http://jetsetspray.com

**7100-SK**

# **JET-SET® 7100-SK**

## **JET PACK 7100 PUMP SEAL KITS**

**FOR OLD STYLE PUMP ONLY**



**Used in both new and old style pumps**

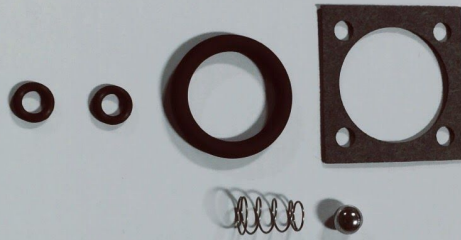

**Used in New style pump only**

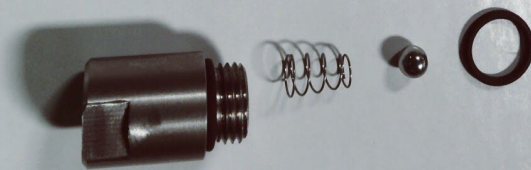

Established 1963  
jetsetspray.com



# JET-SET® GUIDES

(248) 545-4441

info@jetsetspray.com

http://jetsetspray.com

## 7100 Manifold Assembly

# JET-SET® 7100-PUMP

## JET PACK 7100 PUMP MANIFOLD ASSEMBLY



Mount from behind  
827 Lock Washer  
124-M 2pc

7122-1  
Single manifold comes in two,  
three's a 7122-2 and 7122-3

### JET-SET® Plans

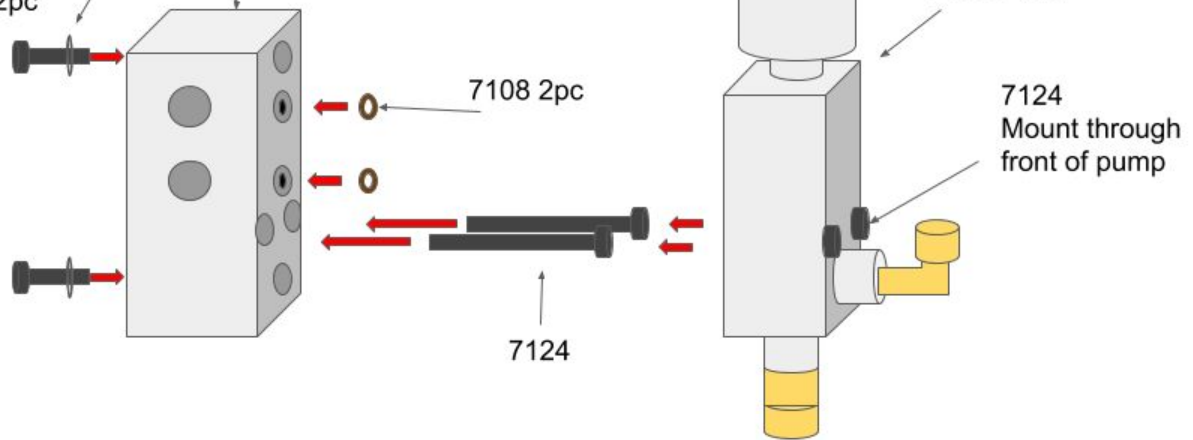

Established 1963  
jetsetspray.com





# JET-SET® GUIDES

## Valve Operation 1400-JP

(248) 545-4441  
info@jetsetspray.com  
http://jetsetspray.com

### Quality

1400-JP air valves are high speed, heavy duty units, designed for general service on all types of automation, for a wide range of air cylinders. These diecast units are direct solenoid actuated: that is, the solenoid plunger directly actuates the spool of the valve. The result is the simplest valve construction on the market today.

They are quality air valves, precision built for rugged service, and offer all the advanced design features of other JETSET® valves.

The 1400-JP offers durability and performance that will give reliable and trouble free service far exceeding industrial standards of design and performance.

### GENUINE MULTI-PURPOSE CONSTRUCTION

The valves are used for the control of air cylinders where part stroke stopping or inch-ing of the cylinder is not required. They are genuine multi-purpose valves: that is, they may be used as normally open or closed 2 or 3-way valves, single or dual pressure 4-ways, or as selector or diverter valves, dependent only on how they are piped or plugged. Full back pressure at any port has no operating effect on the valve.

**PLUG IN SOLENOID AND 4FT. OR 6 FT CORD-CABLE ASSEMBLY WITH GROUND PIN**  
**OR**  
**HARDWIRED SOLENOID WITH 15" LEADS 48" LEADS OPTIONAL**

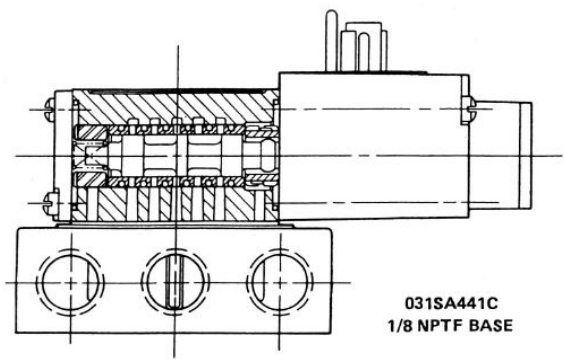
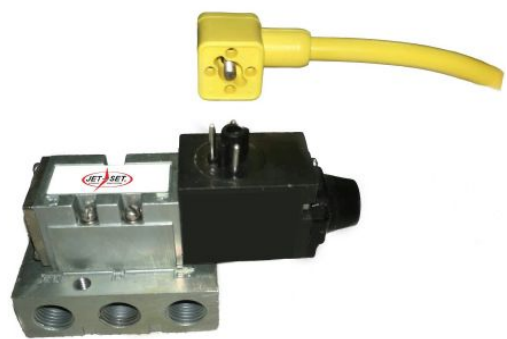

031SA441C  
1/8 NPTF BASE

### COMPACT DESIGN AND HIGH FLOW CAPACITY

Although 1400-JP valves are small in size, sound design still permits ample swing clearance between pots for ease of piping. They save space and weight in machine design as well. Despite their small size, the superior design of the 1400-JP valve allows a normal  $C_v$  of .35

### LAPPED SPOOL AND SLEEVE

JETSET® valves employ a lapped spool and floating sleeve principle for most reliable operation and longest service life. Each 1400-JP valve has its own matched set spool and sleeve, precision machined to millionths of an inch, eliminating always troublesome dynamic O-ring seals.

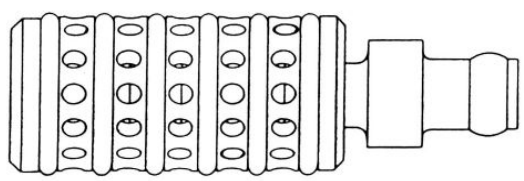

### SOLENOID DESIGN

For all JETSET® valves, next to the lapped spool and sleeve, the most important single component is the solenoid. Our experience has shown that the most reliable valve operation results from a marriage of the spool and sleeve with the time tested and proven direct solenoid construction. With this design, the solenoid pushes directly on the spool and produces a very fast response.



Established 1963  
jetsetspray.com





# JET-SET® GUIDES

## Valve Operation 1400-JP

(248) 545-4441  
 info@jetsetspray.com  
 http://jetsetspray.com

### MANUAL OVERRIDE

A non-locking, manual operator is standard to aid in machine setup and tryout. The operator is recessed to prevent accidental operation. A flush locking override is optional.

1400-JP valves contain a multi-purpose floating sleeve and spool with no dynamic rubber seals to wear out. All valves are 5-ported, 4-way, 2-position valves that may be used as 2-way, 3-way, 4-way, selector or diverter valves. They are fully balanced and pressures through the main valve do not affect the pilot pressures or solenoid force required to shift the spool.

Direct solenoid actuated valves are available in two configurations:

Double solenoid detented valves are actuated by either a "momentary" or a "Maintained" electrical signal alternately on each solenoid. The detent holds the spool in position after electrical power is removed and prevents inadvertent spool shift due to vibration or shock.

Air piloted valves function the same as the solenoid valves except that air signals replace electrical signals. They also offer one important additional feature. Air piloted valves with spring return also have a pilot port on the spring end. An air signal on CB allows the spool to be reversed even when the signal on CA cannot be removed.

### A.N.S.I. SYMBOLS

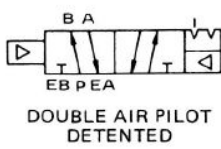
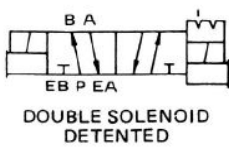

### SPECIFICATIONS

**ELECTRICAL:** Solenoids are continuous duty rated. Standard A.C. voltages are 24/50-60, 120/50-60, and 230/50-60, Standard D.C. voltages are 12VDC and 24VDC.

		A.C.	D.C.
Inrush Current:(amps)	@120/60	.0858	-
Holding Current:(amps)	@120/60	.50	-
Wattage:		5.0	6.0
Time to energize:(secs)	Single Solenoid	.008	.012
	Double Solenoid	.008	.012
Time to de-energize:(secs) (single Only)		.010	.006
	Maximum cycle rate: (continuous)		
	Single Solenoid	1000cpm	500cpm
	Double Solenoid	500cpm	500cpm

### TEMPERATURE RANGE:

Solenoid Valves: -10deg F to +155deg F ambient  
 Air Piloted Valves: -10deg F to +200deg F ambient

### PRESSURE RANGE:

Main Valve: 28deg Hg. vacuum to 150 PSIG  
 Pilot Pressures:  
 Spring return: 15-100 PSIG  
 Dtented: 10-100 PSIG

**NOTE:** Maximum pressure and temperature may depend on the tubing used.

**FLOW CAPACITY:** ¼ NPTF Base: C<sub>v</sub> = .35  
 10-32 Ports with .109 I.D. Fitting installed: C<sub>v</sub> = .18

**SERVICE:** Valves can be used on the following properly filtered media: Lubricated air, dry (oil free) air, vacuum, and non-corrosive, nontoxic, nonflammable dry gasses. Contact us for a list of recommended lubricants and filtration requirements for unlubricated service



Established 1963  
 jetsetspray.com



# JET-SET® GUIDES

## Valve Operation 1400-JP

(248) 545-4441  
 info@jetsetspray.com  
 http://jetsetspray.com

INDIVIDUAL VALVE MODEL SELECTION CHART				
VALVE TYPE	MODEL NUMBER		BASE DESCRIPTION (Add to the model number)	WIRING OPTION (Add to base number)
	10-32 UNF-3B	1/8 NPTF		
Single Solenoid 2-Position Spring Return	030SA4	031SA4	*00 = Valve Unit Only - No Base *01 = Valve Unit with Speed Control 41 = Base w/ Side Ports, Ind'l. Exhaust 56 = Base w/ Bottom Ports, Individual Exhaust <u>10-32 Ports Only</u> 58 = No. 56 with Speed Control <u>10-32 Ports Only</u>	O = Mom Plug-in Std. A.C. or Air Pilot B = Non Plug-in Std. D.C. C = Plug-in Std. A.C. E = Plug-in Std. D.C.  For Plug-in Solenoids, Options C and E, Order Cord Assembly Separately.  Plug w/4' Cord, No. 230-214A Plug w/6' Cord, No. 230-260A
Double Solenoid 2-Position Detented	030SSA4	031SS4		
Single Air Pilot 2-Position Spring Return	030PA4	031PA4		
Double Air Pilot 2-Position Detented	030PP4	031PPA		
Special Options: Add to Model Number		"011B" Flush Looking Override "013A" 48" Solenoid Leads		Example: 031SA441C 120/60

### PRECAUTIONS

#### PIPING

1. Use appropriate I.D. piping.
2. Before piping flush out to remove dust, scale, chips, seal tape, ect. In the pipeline both on the supply line ( supply pressure port side).
3. In the case of 3 position closed center valve, check leakage from piping and fitting between the valve and cylinder be means of soapy water to ensure that there is no leakage. Also, Check the leakage from the cylinder rod seal and piston seal. If there is any leakage, sometimes the cylinder, when the valve is de-energized, can move without stopping at midposition. Therefore, leakage from piping and fitting should be avoided.
4. When applying teflon sealing tape to the thread area, wind it around the thread area 1-2 times and fasten it with fingernail. Be sure the thread extends one or two screw pitches beyond the taped area. Also, when applying liquid seal materials, leave 1-2 threads from the end dry, and avoid over-application.

Never apply to the female side of the equipment.

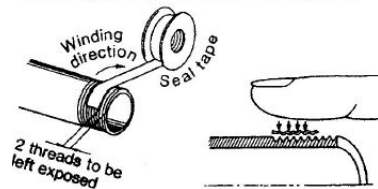

#### CLAMPING TORQUE

Thread	Correct clamping torque inch-lbs (kgf?cm <sup>2</sup> )
10-32 Nom (M5)	13.0-17.3 (15-20)



Established 1963  
 jetsetspray.com



# JET-SET® GUIDES

## Valve Operation 1400-JP

(248) 545-4441  
info@jetsetspray.com  
http://jetsetspray.com

### MOUNTING

Single-acting valves can be mounted in any direction. In the case of a double solenoid valve or 3 position valve in a place subject to vibration, the valve should be aligned perpendicular to the vibration. (Never use it in a vibration condition of more than 5G.)

### ENVIRONMENTAL CONDITIONS

1. When the valve is installed in a dusty area, protect the cylinder rod area to prevent dust from entering the secondary piping via the rod area. Install a silencer or elbow fitting with its outlet downward to prevent dust from entering the exhaust port of the valve.
2. When used in environmental conditions such as corrosive gas, chemicals or chemical solutions, steam, sea water, or temperatures higher than 140deg F (60 deg C), ect, contact us.

### LUBRICATION

**Valves are pre-lubricated. No further lubrication is necessary.**

If a lubricant is used (if required for cylinder, ect) install lubricator in the supply side piping. Please note that the recommended lubricant is turbine oil#1 (ISO VG32) (Never use spindle oil or machine oil) In addition, when the valve is used at low temperature, low temperature oil should be used. The use of turbine oil at temperatures lower than 32deg F (0deg C) leads to increased viscosity and causes the valve to malfunction.

### LEAKING VOLTAGE

It must be noted that in case of connecting C-R element parallel to switching element, leakage current flows through C-R element and the leak voltage increases.

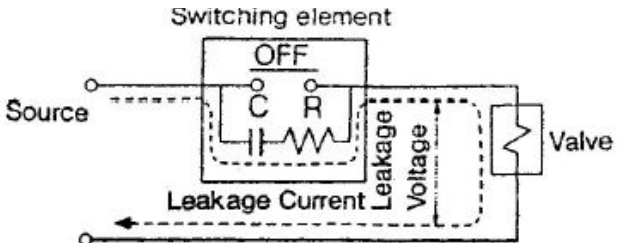

Ensure that any voltage leakage across the coil is as follows:

- AC coil: No more than 20Percent of the rated voltage
- DC coil: No more than 3 percent of the rated voltage.

### MAINTENANCE

1. Excess carbon power and oil waste from air source (mostly from compressor) entering into the valve can lead to increased spool seal resistance and cause valve malfunction. In the worst case the spool can adhere to the valve. It is important to check the quality of air often. Please note that is SUP pressure is left under pressurization for a long time with inferior quality air, carbon powder and oil waste in he compressed air can deposit in the clearance between the spool and sleeve, buildup, and cause the spool to adhere to the valve. To remedy this case, check the compressor oil and use the appropriate least oxidizing compressor oil. A high filtration Mist Separator (Series NAFM) installed behind a regular filter (Series NAF) can prevent foreign particles from entering the valve.
2. If waste from the air source adheres to spool and sleeve, disassemble adaptor plate area and end plate area (return spring insert area) Remove spool and sleeve from valve and cleanse them with trichlorane or freon solutions. When cleaning, prevent O-rings from contacting cleaning solutions. **Be sure to keep each spool and sleeve assembly paired.**
3. When disassembling and reassembling, please ensure that all components are in their proper positions. Prevent gaskets from slipping, and tighten bolts equally.



Established 1963  
jetsetspray.com



# JET-SET® GUIDES

## Tips For Spraying

(248) 545-4441  
 info@jetsetspray.com  
 http://jetsetspray.com

The JETSET® Hydraulic Spray System Assures a controlled deposit on any configuration. First, the spray displacement can vary from zero to full capacity by adjusting the volume control on the pump. And second, the velocity can be controlled from a soft, gentle spray to a full strong blast by regulating the pressure in the air supply.

The Following three sketches show how the coverage and pattern can be varied without changing tips.

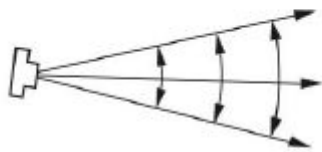

1 DISTANCE FROM TIP INCREASES COVERAGE

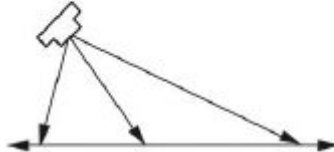

2 ANGLE OF TIP BROADENS COVERAGE

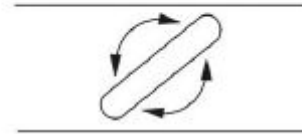

3 WIDTH OF FLAT SPRAY COVERAGE CAN BE CHANGED BY TURNING TIP

JET-SET® HYDRAULIC SPRAY KITS ARE SHIPPED WITH AN 80015 FLAT SPRAY TIP. THE FOLLOWING INTERCHANGEABLE TIPS ARE AVAILABLE FOR SPECIFIC NEEDS.



SOLID ROUND SPRAY

CODE	ACTUAL ORIFICE	ANGLE
TG 0.4	.022	63°
TG 1	.036	60°
TG 2	.047	50°
TG 3	.062	65°

\*

\* Popular Sizes



HOLLOW ROUND SPRAY

CODE	ACTUAL ORIFICE	ANGLE
TY 14	.059	68°
TX 10	.060	76°
T8W	.063	136°

\*

\* Popular Sizes



FLAT SPRAY

CODE	EQUIVALENT ORIFICE	ANGLE
5001	.026	60°
80015	.031	90°
110015	.031	120°

\*\*

\*

\* Popular Sizes \*\* Most Popular

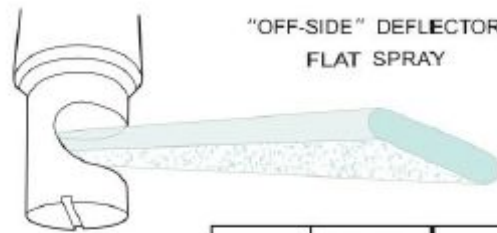

"OFF-SIDE" DEFLECTOR FLAT SPRAY

CODE	ACTUAL ORIFICE	ANGLE
TK 1.5	.040	140°
TK 2.5	.051	140°

\*

\* Popular Sizes

NOTE: Other tips are available. For recommendation, submit pint sample of liquid and details of operation.



Established 1963  
 jetsetspray.com





# JET-SET® GUIDES

## Spray Angle and Coverage

(248) 545-4441  
 info@jetsetspray.com  
 http://jetsetspray.com

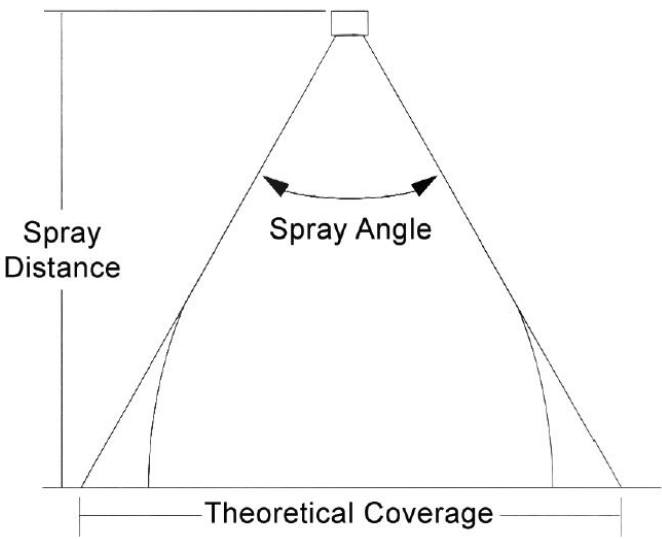

Tabulated spray angles indicate approximate spray coverages based on spray or distribution of water. In actual spraying, the effective spray angle varies with spray distance. Liquids more viscous than water form relatively smaller spray angles ( or even solid stream), depending upon viscosity, nozzle capacity and spraying pressure. Liquids with surface tensions lower than water will produce relatively wider spray angles than those listed for water. This table list the theoretical coverage of spray patterns as calculated from the included spray angle of the spray and the distance from the nozzle orifice. Values are based on the assumption that the spray angle remains the same throughout the entire spray distance. In actual practice the tabulated spray angle does not hold for long spray distances. If spray coverage requirement is critical contact JETSET® for help in determining the specs.

**Theoretical Spray Coverage**  
 at Various Distances in Inches (cm) from Nozzle Orifice

Spray Angle	2"	5 cm	4"	10 cm	6"	15 cm	8"	20 cm	10"	25 cm	12"	30 cm	15"	40 cm	18"	50 cm	24"	60 cm	30"	70 cm	36"	80 cm	48"	100 cm
5°	.2	.4	.4	.9	.5	1.3	.7	1.8	.9	2.2	1.1	2.6	1.3	3.5	1.6	4.4	2.1	5.2	2.6	6.1	3.1	7.0	4.2	8.7
10°	.4	.9	.7	1.8	1.1	2.6	1.4	3.5	1.8	4.4	2.1	5.3	2.6	7.0	3.1	8.8	4.2	10.5	5.2	12.3	6.3	14.0	8.4	17.5
15°	.5	1.3	1.1	2.6	1.6	4.0	2.1	5.3	2.6	6.6	3.2	7.9	3.9	10.5	4.7	13.2	6.3	15.8	7.9	18.4	9.5	21.1	12.6	26.3
20°	.7	1.8	1.4	3.5	2.1	5.3	2.8	7.1	3.5	8.8	4.2	10.6	5.3	14.1	6.4	17.6	8.5	21.2	10.6	24.7	12.7	28.2	16.9	35.3
25°	.9	2.2	1.8	4.4	2.7	6.7	3.5	8.9	4.4	11.1	5.3	13.3	6.6	17.7	8.0	22.2	10.6	26.6	13.3	31.0	15.9	35.5	21.2	44.3
30°	1.1	2.7	2.1	5.4	3.2	8.0	4.3	10.7	5.4	13.4	6.4	16.1	8.1	21.4	9.7	26.8	12.8	32.2	16.1	37.5	19.3	42.9	25.7	53.6
35°	1.3	3.2	2.5	6.3	3.8	9.5	5.0	12.6	6.3	15.8	7.6	18.9	9.5	25.2	11.3	31.5	15.5	37.8	18.9	44.1	22.7	50.5	30.3	63.1
40°	1.5	3.6	2.9	7.3	4.4	10.9	5.8	14.6	7.3	18.2	8.7	21.8	10.9	29.1	13.1	36.4	17.5	43.7	21.8	51.0	26.2	58.2	34.9	72.8
45°	1.7	4.1	3.3	8.3	5.0	12.4	6.6	16.6	8.3	20.7	9.9	24.9	12.4	33.1	14.9	41.4	19.9	49.7	24.8	58.0	29.8	66.3	39.7	82.8
50°	1.9	4.7	3.7	9.3	5.6	14.0	7.5	18.7	9.3	23.3	11.2	28.0	14.0	37.3	16.8	46.6	22.4	56.0	28.0	65.3	33.6	74.6	44.8	93.3
55°	2.1	5.2	4.2	10.4	6.3	15.6	8.3	20.8	10.3	26.0	12.5	31.2	15.6	41.7	18.7	52.1	25.0	62.5	31.2	72.9	37.5	83.3	50.0	104
60°	2.3	5.8	4.6	11.6	6.9	17.3	9.2	23.1	11.5	28.9	13.8	34.6	17.3	46.2	20.6	57.7	27.7	69.3	34.6	80.8	41.6	92.4	55.4	115
65°	2.5	6.4	5.1	12.7	7.6	19.1	10.2	25.5	12.7	31.9	15.3	38.2	19.2	51.0	22.9	63.7	30.5	76.5	38.2	89.2	45.8	102	61.2	127
70°	2.8	7.0	5.6	14.0	8.4	21.0	11.2	28.0	14.0	35.0	16.8	42.0	21.0	56.0	25.2	70.0	33.6	84.0	42.0	98.0	50.4	112	67.2	140
75°	3.1	7.7	6.1	15.4	9.2	23.0	12.3	30.7	15.3	38.4	18.4	46.0	23.0	61.4	27.6	76.7	36.8	92.1	46.0	107	55.2	123	73.6	153
80°	3.4	8.4	6.7	16.8	10.1	25.2	13.4	33.6	16.8	42.0	20.2	50.4	25.2	67.1	30.3	83.9	40.3	101	50.4	118	60.4	134	80.6	168
85°	3.7	9.2	7.3	18.3	11.0	27.5	14.7	36.7	18.3	45.8	22.0	55.0	27.5	73.3	33.0	91.6	44.0	110	55.0	128	66.0	147	88.0	183
90°	4.0	10.0	8.0	20.0	12.0	30.0	16.0	40.0	20.0	50.0	24.0	60.0	30.0	80.0	36.0	100	48.0	120	60.0	140	72.0	160	96.0	200
95°	4.4	10.9	8.7	21.8	13.1	32.7	17.5	43.7	21.8	54.6	26.2	65.5	32.8	87.3	39.3	109	52.4	131	65.5	153	78.6	175	105	218
100°	4.8	11.9	9.5	23.8	14.3	35.8	19.1	47.7	23.8	59.6	28.6	71.5	35.8	95.3	43.0	119	57.2	143	71.6	167	85.9	191	114	238
110°	5.7	14.3	11.4	28.6	17.1	42.9	22.8	57.1	28.5	71.4	34.3	85.7	42.8	114	51.4	143	68.5	171	85.6	200	103	229	-	286
120°	6.9	17.3	13.9	34.6	20.8	52.0	27.7	69.3	34.6	86.6	41.6	104	52.0	139	62.4	173	83.2	208	104	243	-	-	-	-
130°	8.6	21.5	17.2	42.9	25.7	64.3	34.3	85.8	42.9	107	51.5	129	64.4	172	77.3	215	103	257	-	-	-	-	-	-
140°	10.9	27.5	21.9	55.0	32.9	82.4	43.8	110	54.8	137	65.7	165	82.2	220	98.6	275	-	-	-	-	-	-	-	-
150°	14.9	37.3	29.8	74.6	44.7	112	59.6	149	74.5	187	89.5	224	112	299	-	-	-	-	-	-	-	-	-	-
160°	22.7	56.7	45.4	113	68.0	170	90.6	227	113	284	-	-	-	-	-	-	-	-	-	-	-	-	-	-
170°	45.8	114	91.6	229	-	-	-	-	-	-	-	-	-	-	-	-	-	-	-	-	-	-	-	-



Established 1963  
 jetsetspray.com



# JET-SET® GUIDES

## Spray Tips

(248) 545-4441  
info@jetsetspray.com  
http://jetsetspray.com

Spray tips are available in a wide variety of materials, capacities, and patterns. For specific information about spray tips of or different patterns other than indicated here, please contact us.

The following spray tips are regularly stocked at **JET-SET®**

### FLAT SPAY (TP)

Tip #	Orifice	Spray Angle (approx.)	TP
902- 5001	.026"	50° @ 40psi / 60° @ 80psi	
902- 6501	.026"	65° @ 40psi / 74° @ 80psi	
902- 80015	.031"	80° @ 40psi / 90° @ 80psi	
902- 800050	.018"	80° @ 20psi / 95° @ 80psi	
902- 110015	.031"	110° @ 40psi / 120° @ 80psi	

### FULL CONE (TG)

Tip #	Orifice	Spray Angle (approx.)	TG
902- TG 0.3	.020"	50° @ 20psi / 61° @ 80psi	
902- TG 0.4	.022"	56° @ 20psi / 63° @ 80psi	
902- TG 0.6	.027"	54° @ 20psi / 62° @ 80psi	
902- TG 1	.036"	58° @ 20psi / 53° @ 80psi	
902- TG 2	.047"	50° @ 20psi / 46° @ 80psi	
902- TG 3	.062"	65° @ 20psi / 59° @ 80psi	



Established 1963  
jetsetspray.com





# JET-SET® GUIDES

## Spray Tips

(248) 545-4441  
info@jetsetspray.com  
http://jetsetspray.com

### DEFLECTED FLAT SPRAY (TK)

Tip #	Orifice	Spray Angle (approx.)	TK
902- TK 1.5	.040"	108° @ 20psi / 130° @ 60psi	
902- TG 2.5	.052"	122° @ 20psi / 133° @ 60psi	

### HOLLOW CONE (TX/TY)

Tip #	Orifice	Spray Angle (approx.)	TX / TY
902- TX 10	.059"	68° @ 20psi / 74° @ 40psi	
902- TY 14	.070	70° @ 20psi / 76° @ 40psi	



Established 1963  
jetsetspray.com



# JET-SET® GUIDES

## Nozzle Assemblies

(248) 545-4441  
 info@jetsetspray.com  
 http://jetsetspray.com

<b>Part# 900 (O/A Length 1 7/8" Approx.)</b>		<b>Female Nozzle Assembly</b>
1pc	901 Nozzle Nut	
1pc	902-80015 Standard Spray Tip	
1pc	903 20 (40) 20 or 40lb Check Valve	
2pc	904 Nozzle Bracket	
1pc	905 Nozzle Body	

<b>Part# 900-1/8MT (O/A Length 1 3/4" Approx.)</b>		<b>Male Nozzle Assembly</b>
1pc	901 Nozzle Nut	
1pc	902-80015 Standard Spray Tip	
1pc	903 20 (40) 20 or 40lb Check Valve	
2pc	904 Nozzle Bracket	
1pc	905-1/8 MT Nozzle Body	

<b>Part# 902-80015-M20 (O/A Length 7/8" Approx)20lb Check Valve</b>		<b>Mini Nozzle</b>
OR		
<b>Part# 902-80015-MNV (O/A Length 7/8" Approx)No Check Valve</b>		

<b>Part# 908-SW 1/8x1/8 (O/A Length 1 1/4" Approx.)</b>		<b>Mini Nozzle</b>
Swivel For 900-1/8M or 902-80015-M's		



Established 1963  
 jetsetspray.com