

H-series

column style hydraulic presses

Standard Features

- Dual palm button anti-tie-down controls
- Main power disconnect
- NFPA-79 compliant electrical controls
- Industry standard components
- NEMA enclosures and TEFC motor
- Emergency stop & return buttons
- Magnetic motor starter
- Pressure reversal
- Hydraulic decompression control
- In reservoir hydraulic pump for quiet operation
- Inch/Operate selector switch
- Heat exchanger



H-Series 4-Post Press

H-series presses are built to each customer's exacting specifications. Reference Table 1 (below) for specifications necessary to fit your application

Table 1

Tonnage	
Dimensional Information	
(A) Left to Right (Distance Between Pins)	
(B) Front to Back (Distance Between Pins)	
(C) Daylight	
(D) Stroke	
(E) Work Height	
(F) Overall Width	NA
(G) Depth	NA

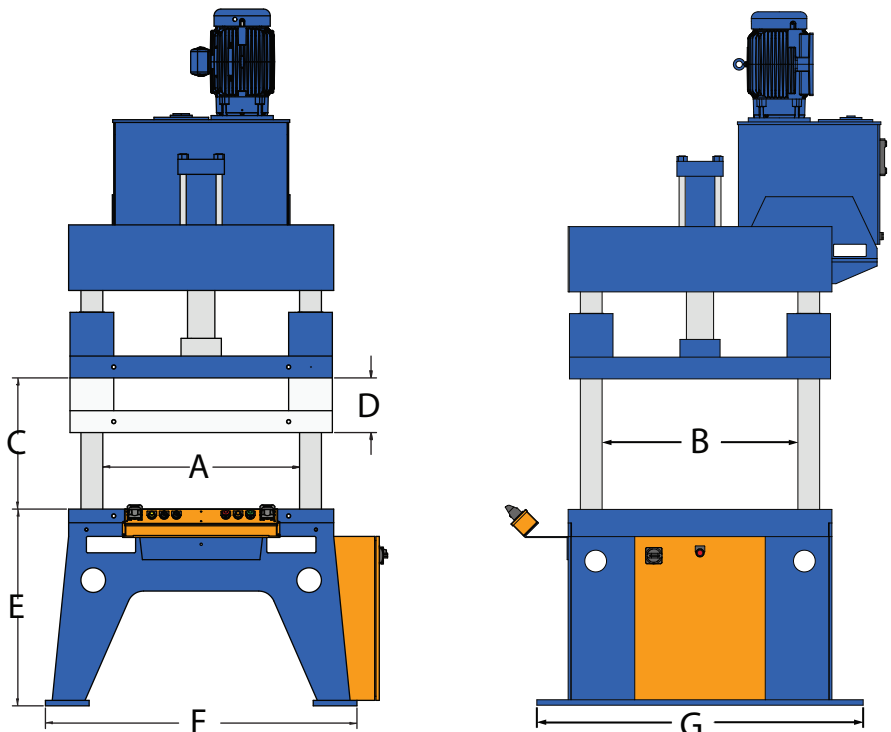

NOTE: Neff also offers 2-Post presses. Please contact the factory or your local representative.

Neff Press design and manufactures column presses from 2 -5000 tons with various dimensions. Please use the table above to fill out your press specifications.

Making the presses that make the products that make the World work



6510 Page Ave.
 St. Louis, MO 63133
 Phone: (800) 325-8612
 Fax: (314) 725-2230
 Website: www.neffpress.com

Options

Neff Press offers an extensive array of optional equipment in order to customize your post press to ensure it meets your application specifications. Common options include:

- Knock-out cylinders
- Press guarding systems
- Lube systems
- Slide safety clamp
- Water glycol compatible
- Pre-fill hydraulic circuits
- Cooled Platens
- Heat Exchangers
- One/Two-hand trip
- Die cushions
- RCS packages (ram control)
- Force/Distance monitoring
- Automatic press cycle
- Safety die block
- Speed control
- High speed power units
- Cushion knock-outs
- Foot control
- Explosion-proof controls
- Heated platens
- Shuttle systems
- Air to oil coolers
- Frame modifications
- Bolster machining
- CNC controls
- Dwell timers
- Feed Integration